

Proclamation

3a.

Town of Indian River Shores
National Safe Boating Week
May 16–22, 2026

WHEREAS, recreational boating and paddling is a popular pastime in our community, enjoyed by residents and visitors alike; and

WHEREAS, safe boating and paddling practices and the consistent use of life jackets are essential to preventing accidents and saving lives on our waterways; and

WHEREAS, the United States Coast Guard Auxiliary, in partnership with local agencies and organizations, is dedicated to promoting boating safety through education, vessel safety checks, and public outreach; and

WHEREAS, National Safe Boating Week, observed May 16 through May 22, 2026, serves as an annual reminder for all boaters and paddlers to practice safe boating and paddling habits and to always wear a life jacket while on the water; and

WHEREAS, the theme of National Safe Boating Week, “Wear It!” emphasizes the importance of life jacket use and encourages all boaters and paddlers to set a positive example for others;

NOW, THEREFORE, the Town of Indian River Shores, does hereby proclaim May 16–22, 2026, as

NATIONAL SAFE BOATING WEEK

The Town Council of the Town of Indian River Shores urges all citizens to support boating safety efforts, participate in boating safety education, and always wear a life jacket while boating and paddling.

IN WITNESS WHEREOF, I have hereunto set my hand and caused the Seal of the Town of Indian River Shores to be affixed this 23rd day of April, 2026.



Brian T, Foley, Mayor
Town of Indian River Shores

Digital Infrastructure Modernization

Email Migration | Website Consolidation | New Seal & Brand

Town of Indian River Shores

Modernization Overview

3

Initiatives

Email · Website · Brand

1

Unified Domain

indianrivershores.gov

1

New Seal & Brand

Unified Identity

Objective: Modernize the Town's digital infrastructure across three workstreams: consolidate email under **Unified Communications Platform** on the **indianrivershores.gov** domain; merge legacy websites into a single unified site; and introduce a new official seal and brand identity.

Domain Consolidation

BEFORE

Town Hall

RETIRED

@irshores.com

Legacy Email Platform

Public Safety

RETIRED

@irspsd.org

Unified Communications Platform



Consolidated

AFTER

Town Hall + Public Safety

ACTIVE

@indianrivershores.gov

Unified Platform

- Single domain for all staff
- Unified Global Address List
- Shared calendars across departments
- Consistent mail routing & security policy

Platform Migration

TOWN HALL — RETIRED

Legacy Email Platform

- Email (irshores.com domain)
- Shared Calendar
- Contacts / Directory
- File Storage (separate migration)



UNIFIED PLATFORM — ACTIVE

Unified Platform

- Email (@indianrivershores.gov)
- Shared Calendar — across depts.
- Global Address List (all staff)
- Cloud Storage integration

Website Consolidation

BEFORE

Town Website

RETIRED

irshores.com

Separate CMS

Public Safety Website

RETIRED

irspsd.org

Separate CMS



Consolidated

AFTER

All Town Departments

ACTIVE

indianrivershores.gov

Single CMS Platform

- Single URL for all Town departments
- Consistent navigation & branding
- Centralized content management
- Reduced maintenance overhead

New Seal & Brand Identity

LEGACY IDENTITY — RETIRED



Original Tree Badge Logo
Legacy Town logo



NEW IDENTITY — ACTIVE



Official Seal
For official documents



Brand Logo
All Town communications

- Seal: official documents, resolutions & certifications.
- Mission Statement: To provide a high level of personal service with integrity and professionalism to ensure an unparalleled quality of life.
- Logo: Town-wide website, letterhead, signage & communications; Public Safety retains specialized departmental identity with Town logo incorporated.

Modernization Status

Email: Account Audit & Inventory

All Town Hall and Public Safety accounts, aliases, and distribution lists catalogued

Complete

Email: Domain & Platform

indianrivershores.gov provisioned; mailbox migration underway — expected completion this week

In Progress

Email: Legacy Forwarding & GAL Sync

irshores.com and irspsd.org forwarding active; unified Global Address List synced

In Progress

Website: Consolidation to Single Site

Merge legacy Town and Public Safety sites into single indianrivershores.gov web presence

In Progress

Seal & Brand: New Identity Rollout

Deploy new seal and brand standards Town-wide; Public Safety to incorporate within their departmental identity

In Progress

Email: Legacy Domain Retirement

Decommission irshores.com and irspsd.org after minimum one-year forwarding window

Pending

Next Steps

1

Email: Complete Forwarding & Address List

Verify MX/forwarding records are propagated and confirm all staff appear correctly in the unified Global Address List.

2

Email: Monitor Mail Flow & Retire Domains

Track inbound/outbound delivery for bounced messages; decommission irshores.com and irspsd.org after one-year forwarding window.

3

Website: Launch Consolidated Site

Migrate content from legacy Town and Public Safety sites; launch single unified site under indianrivershores.gov; redirect old URLs.

4

Brand: Deploy New Seal & Identity

Roll out new seal and brand standards across Town communications. Coordinate with Public Safety on incorporation of Town logo within their departmental identity.



OFFICIAL MINUTES

REGULAR TOWN COUNCIL MEETING

Thursday, March 26, 2026 – 9:00 AM

Town of Indian River Shores

6001 Highway A1A Indian River Shores, FL 32963

The regular meeting of the Town Council of the Town of Indian River Shores was held on Thursday, March 26, 2026, at 9:00 a.m. in Council Chambers, 6001 Highway A1A, Indian River Shores. Those present were Brian Foley, Mayor; Bob Auwaerter, Vice Mayor; Sam Carroll, Councilmember; James Altieri, Councilmember and Peter Tedesco, Councilmember. Also present were James Harpring, Town Manager; Heather Christmas, Finance Director; Peter Sweeney, Town Attorney and Janice C. Rutan, Town Clerk.

1. **Call to Order**

- a. Invocation
- b. Pledge of Allegiance
- c. Roll Call

Mayor Foley called the meeting to order at 9:00 a.m. Councilmember Carroll offered the Invocation. Mayor Foley led the Pledge of Allegiance. The Town Clerk called the roll. All members were present.

2. **Agenda Reordering, Deletions, or Emergency Additions**

There being no reordering, deletions or emergency addition to the agenda, a motion was made by Councilmember Carroll, Seconded by Councilmember Altieri and unanimously passed (5-0) to approve the agenda as presented.

3. **Presentations/Proclamations**

- a. Presentation of the September 30, 2025, Financial Statements – Christine Noll-Rhan of Carr, Riggs & Ingram, LLC

Christine Noll-Rhan of Riggs & Ingram, LLC presented an overview of the Town’s audited financial statements for the fiscal year ending September 30, 2025, noting a clean audit with no findings.

Vice Mayor Auwaerter commended the Town Council, Town Manager and Staff for their fiscal oversight, highlighting fully funded pension funds, a reduced millage rate and a strong fund balance.

- b. Proclamation declaring the Town of Indian River Shores a Moonshot Community

Marie O’Brien of the Learning Alliance addressed the Town Council highlighting the achievements of the alliance with 90% of Indian River County children reading at grade level by the third grade. Ms. O’Brien thanked the Town for its longstanding support. A film highlighting the program will be available on You Tube after April 15, 2026, following the Vero Beach Film Festival.



Mayor Foley read the Proclamation into the record and presented it to the representees of the Learning Alliance and Moonshot Community.

c. Proclamation designating April 2026 Florida Water Conservation Month

Mayor Foley read the Proclamation into the record.

d. Utility Legislation – HB 1451

The Council discussed the passage of HB 1451 during the final minutes of the legislative session. Although not yet signed or vetoed, the bill revises reporting requirements for municipal utilities providing services outside their corporate boundaries. Town Manager James Harpring offered a power point overview.

Beginning January 1, 2027, and annually thereafter, affected municipalities would be required to report specified data to the Public Service Commission. If signed by the Governor it would be effective July 1, 2027.

The Public Service Commission would also review transfers into the general fund with Vice Mayor Auwaerter noting the City of Vero Beach transfers 6% of its revenues to their general fund.

Following discussion regarding utilities provided by the City of Vero Beach, the Council authorized the Town Manager to resend correspondence to the Governor and legislative representatives in support of HB 1451 which addresses the disenfranchisement of non-voting utility customers and supports oversight of revenue transfers.

4. Comments From the Public Regarding Agenda Items(s)

None.

5. Consent Agenda

- a. Approval of Minutes of Town Council Meeting dated February 17, 2026
- b. Approval of September 30, 2025 Audited Financial Statements
- c. Review of Site Plan Modification - Marbrisa Pickleball Courts

A motion was made by Councilmember Carroll, seconded by Councilmember Altieri, and unanimously passed (5-0) to approve the Consent Agenda as presented.

6. Mayor's Report

Mayor Foley reported meeting with the Town Clerk, City of Vero Beach Commissioner Aaron Vos, and the retired City of Vero Beach Town Clerk Tammy Bursick regarding the upcoming 4th of July celebration being planned. As part of the Nation's 250-year anniversary, each municipality will prepare a historical time capsule. The Town Clerk will coordinate this effort, and Ms. Bursick will make a presentation to the Town Council at the April meeting.

Mayor Foley discussed property tax reform and cited data from the Tax Collector's office highlighting the average Indian River Shores taxpayer paying \$18,355 compared to the County average of \$4,091. While the Town comprises 6% of the County's tax base, it accounts for 15.96% of the County's assessed ad valorem taxes.

Mayor Foley reminded Council of his prior request for a 5% budget reduction and referenced pending legislation requiring a budget workshop to identify potential 10% reductions prior to budget adoption.

Mayor Foley also reported on legislation that had been submitted to the Governor promoting "nature-based solutions" for shoreline protection and improve coastlines using living seawalls, shoreline and vegetative

planting, and seagrass. He suggested Staff coordinate with St. Lucie County to learn who provides more permanent erosion solutions. Mayor Foley added there was funding available.

Lastly, he requested Council input on potentially amending the Ordinance prohibiting trucks in residential driveways, suggesting public workshops and review of sample ordinances from other jurisdictions. Vice Mayor Auwaerter supported further discussion, noting the increased prevalence of SUVs and pick-up trucks.

Mayor Foley suggested limiting trucks based on Gross Vehicle Weight (GVW) or number of axles, but again, would like input from the community through a scheduled workshop and requested further Council discussion of the subject at the April meeting.

7. Councilmember Items

Councilmember Tedesko reported on the Treasure Coast League of Cities meeting he had attended where Representative Robbie Brackett provided an update on the legislative session.

Councilmember Altieri noted that the Utilities Commission was now meeting bimonthly.

8. Discussion with Possible or Probable Action

a. Selection of Auditor Selection Committee

A motion was made by Vice Mayor Auwaerter, seconded by Councilmember Tedesko, and unanimously passed (5-0) to appoint Councilmember Altieri to serve on the Auditor Selection Committee.

b. Ordinance No. 587 – Short Term Vacation Rental Enforcement (Second Reading)

Town Attorney Sweeney read the title of Ordinance No. 587 into the record. A motion was made by Councilmember Carroll and seconded by Councilmember Altieri to approve Ordinance No. 587 on second reading. The Town Clerk called the roll. All members present voted in the affirmative with the motion passing unanimously 5-0.

c. Ordinance No. 588 – Establishment of Departments (Second Reading)

Town Attorney Sweeney read the title of Ordinance No. 588 into the record. A motion was made by Vice Mayor Auwaerter and seconded by Councilmember Carroll to approve Ordinance No. 588 on second reading. The Town Clerk called the roll. All members present voted in the affirmative with the motion passing unanimously 5-0.

d. Ordinance No. 589 – Repeal of Section 31.05 Contracts required for services (Second Reading)

Town Attorney Sweeney read the title of Ordinance No. 589 into the record. A motion was made by Councilmember Carroll and seconded by Vice Mayor Auwaerter to approve Ordinance No. 589 on second reading. The Town Clerk called the roll. All members present voted in the affirmative with the motion passing unanimously 5-0.

e. Ordinance No. 590 – Repeal of Article VI – Department of Treasury Section 30.45 Organization; powers and duties. (First reading)

Town Manager Harpring presented Staff's report. The adoption of Ordinance 590 clarifies the organizational chart of the Town. Town Attorney Sweeney read the title of Ordinance No. 590 into the record. A motion was made by Councilmember Carroll and seconded by Councilmember Altieri to approve Ordinance No. 590 on first reading. The Town Clerk called the roll. All members present voted in the affirmative with the motion passing unanimously 5-0.

- f. Ordinance No. 591 – Amendment to Article VII, Department of Finance
Section 30.50 – Organization, powers, and duties. (First Reading)

Town Attorney Sweeney read the title of Ordinance No. 591 into the record. A motion was made by Councilmember Carroll and seconded by Councilmember Altieri to approve Ordinance No. 591 on first reading. The Town Clerk called the roll. All members present voted in the affirmative with the motion passing unanimously 5-0.

- g. Ordinance No. 592- Amendment to Section 32.21 – Town Manager (First Reading)

Town Manager Harpring offered Staff’s report. He noted that on page 2 of the Ordinance, Subsection 6, the words “the Chief of Police, Fire Chief or the” are to be struck through as deleted text. Town Attorney Sweeney read the title of Ordinance No. 592 into the record. A motion was made by Vice Mayor Auwaerter to approve Ordinance No. 592 on first reading, as amended, by striking through “the Chief of Police, Fire Chief or the” for deletion from the Ordinance. Councilmember Carroll seconded the motion to approve Ordinance No. 592 on first reading. The Town Clerk called the roll. All members present voted in the affirmative with the motion passing unanimously 5-0.

- h. Ordinance No. 593 – Procurement of Goods and Services (First Reading)

Town Manager Harpring offered Staff’s report. Town Attorney Sweeney read the title of Ordinance No. 593 into the record. A motion was made by Councilmember Carroll and seconded by Councilmember Altieri to approve Ordinance No. 593 on first reading. The Town Clerk called the roll. All members present voted in the affirmative with the motion passing unanimously 5-0.

9. **Staff Updates**

- a. Building Official Report & Statistics
- b. Code Enforcement Report
- c. Public Works Department Report

Town Manager Harpring reported the Building Department was completing training for the new MGO software system. In response to Mayor Foley’s inquiry regarding the posting or real estate signs in the ROW, the Town Manager explained that the Town prioritizes education and encouragement before enforcement. He further advised street sweeping had been completed on all public streets.

- d. Town Treasurer Report

The Town Treasurer was available for questions. Vice Mayor Auwaerter expressed appreciation for her dedication and prompt turnaround in annual reports, audits, and budget preparation.

- e. Public Safety Department Report & Statistics

Assistant Chief Ryer addressed the Town Council. His department has been focusing on traffic enforcement, specifically on school bus infractions.

- f. Town Clerk – Update on 2026 Election

The Town Clerk provided an update on the upcoming Municipal Election on November 3, 2026. A question-and-answer period followed.

10. **Town Attorney Report**

Town Attorney Sweeney reiterated that during the election process, sitting Councilmembers can speak to any potential candidate. He summarized the legislative session with a total of 1,897 bills presented. 195 passed both the house and senate; four have been signed by the Governor, seven are awaiting signature. The remaining bills will become effective by default after 15 days if the Governor does not sign.

11. **Town Manager Report**

Town Manager Harpring offered a brief report on the sand replenishment work being completed at the Fort Pierce inlet by the Army Corps of Engineers. Most of the work is federally funded with St. Lucy County funding approximately 20% of the project.

Town Manager Harpring presented an updated Organizational Chart.

12. Council/Committee Reports or Non-Action Items

- a. Call for Committee Reports, Informational Updates or Comments

Councilmember Tedesko and Councilmember Altieri had no additional comments.

Mayor Foley reported on the Treasure Coast Council of Local Government meeting that provided updates on airport expansion plans from both the Vero Beach Airport and the St. Lucie Airport, scholarship programs, and disaster grant opportunities.

Vice Mayor Auwaerter reported on the Beach and Shores Preservation Committee, the County's update to its beach preservation plan and the ongoing Sector 7 erosion concerns.

13. Call to Audience

None.

14. Adjournment

With no further business to come before the Town Council, the meeting adjourned at 10:45 a.m.

Approved: April 23, 2026

Janice C. Rutan, Town Clerk



AGENDA ITEM

TO: Town Council

FROM: James Harpring, Town Manager

DATE: April 10, 2026

SUBJECT: Review of Request for Construction East of the Coastal Construction Control Line (CCCL) 630 Ocean Road

BACKGROUND:

The Town has a request for construction east of the CCCL at 630 Ocean Road. The project consists of a two-story, single-family dwelling, east swimming pool, guest house, garage, west swimming pool, paver swimming deck, dune walkover and other items noted under Other Structures/Activities in the FDEP Notice to Proceed and Permit for Construction or Other Activities.

Per Section 157.28 (2), Code of Ordinances, Indian River Shores, all applications for construction east of the CCCL, along with any state permits, must be provided to Town Council for final action. All required documentation for Town Council Review has been provided to the Building Department and is attached.

RECOMMENDATION:

Review the request of construction east of the CCCL.

ATTACHMENTS:

1. FDEP Notice to Proceed and Permit for Construction or Other Activities

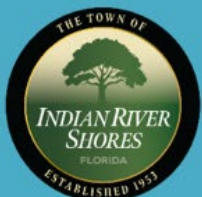



STATE OF FLORIDA
DEPARTMENT OF ENVIRONMENTAL PROTECTION
Office of Resilience and Coastal Protection
Coastal Construction Control Line Program
2600 Blair Stone Road - Mail Station 3522
Tallahassee, Florida 32399-2400
(850) 245-8570

PERMIT NUMBER: IR001100

PERMITTEE

Vitae Advisors, LLC
c/o William Stoddard, Ph.D., P.E.
Schulke, Bittle & Stoddard, LLC
1717 Indian River Boulevard, Suite 201
Vero Beach, Florida 32960

**NOTICE TO PROCEED AND PERMIT FOR CONSTRUCTION OR OTHER ACTIVITIES
PURSUANT TO SECTION 161.053, FLORIDA STATUTES**

FINDINGS OF FACT: An application for authorization to conduct the activities seaward of the coastal construction control line that are indicated in the project description, was filed by the applicant/permittee named herein on October 24, 2025, and was determined to be complete pursuant to rule on February 19, 2026. The proposed major structure is to be located landward of the 30-year erosion projection.

CONCLUSIONS OF LAW: After considering the merits of the proposal and any written objections from affected persons, the Department finds that upon compliance with the permit conditions, the activities indicated in the project description of this permit are of such a nature that they will result in no significant adverse impacts to the beach/dune areas or to adjacent properties; that the work is not expected to adversely impact nesting sea turtles, their hatchlings, or their habitat; that the work is expendable in nature and/or is appropriately designed in accordance with Section 62B-33.005, Florida Administrative Code. The direct and cumulative impacts to the beach and dune system that will be caused by the seaward location of the proposed construction represent the maximum such impact that is acceptable to the Department. Therefore, future construction on the site seaward of the coastal construction control line shall not extend further seaward of the proposed structures approved pursuant to this permit. Based on the foregoing considerations, the Department approves the application; authorizes construction and/or activities at the location indicated below in strict accordance with the project description, the approved plans (if any) and the General Permit Conditions which are by this reference incorporated herein, and any additional conditions shown below, pursuant to Section 161.053(4), Florida Statutes.

EXPIRATION DATE: March 17, 2029

LOCATION: Between approximately 340 feet and 460 feet north of the Department of Environmental Protection's reference monument R-56, in Indian River County. Project address: 630 Ocean Road, Indian River Shores.

PROJECT DESCRIPTION:

Two-Story, Single-Family Dwelling

1. Location relative to control line: A maximum of 177.5 feet seaward.
2. Exterior dimensions: 158.4 feet in the shore-normal direction by 89.7 feet in the shore-parallel direction.

3. Type of foundation: Pile.
4. Finished floor elevation: + 17.9 feet (NAVD).
5. Garage slab elevation: Varies from + 17.3 to + 17.5 feet (NAVD).

East Swimming Pool

1. Location relative to control line: A maximum of 195.2 feet seaward.
2. Exterior dimensions: 11.4 feet in the shore-normal direction by 52.5 feet in the shore-parallel direction.
3. Type of foundation: Pile.
4. Top elevation of swimming pool shell: + 17.3 feet (NAVD).
5. Bottom elevation of swimming pool shell: Varies from +11.3 to +13.3 feet (NAVD).

Guest House

1. Location relative to control line: A maximum of 46.5 feet seaward.
2. Exterior dimensions: 23.5 feet in the shore-normal direction by 32.8 feet in the shore-parallel direction.
3. Type of foundation: Pile.
4. Finished floor elevation: + 17.9 feet (NAVD).

West Swimming Pool

1. Location relative to control line: A maximum of 85.2 feet seaward.
2. Exterior dimensions: 28.5 feet in the shore-normal direction by 12.7 feet in the shore-parallel direction.
3. Type of foundation: Pile.
4. Top elevation of swimming pool shell: + 17.5 feet (NAVD).
5. Bottom elevation of swimming pool shell: Varies from +11.5 to +13.5 feet (NAVD).

Excavation/Fill

1. Total volume of excavation: Approximately 218 cubic yards. **See Special Permit Condition 4.**
2. Location of excavation: A maximum 195.2 feet seaward of the control line.
3. Maximum depth of excavation: To depth of foundation installation.

4. Volume of fill to be placed: Approximately 4,213 cubic yards, including 3,995 cubic yards of imported fill. **See Special Permit Condition 5.**
5. Location of fill to be placed: A maximum 196.4 feet seaward of the control line.

Other Structures/Activities

1. A paver swimming pool deck attached to the periphery of the swimming pools is to be located a maximum of 196.4 feet seaward of the control line
2. A 4-foot-wide dune walkover. **See Special Permit Condition 13 and 14.**
3. A frangible stacked rock wall is to be located seaward of the dwelling, as shown on the approved plans.
4. Frangible retaining walls around the perimeter of the development, as shown on the approved plans.
5. Subsurface storm water runoff drainage system is to be located landward of the dwelling.
6. Landscape plantings, to include native salt-tolerant vegetation. **See Special Permit Condition 6.**
7. Exterior and pool lighting. **See Special Permit Condition 7-12.**

SPECIAL PERMIT CONDITIONS:

1. Prior to commencement of construction activity authorized by this permit, a preconstruction conference shall be held at the site among the contractor, the owner or authorized agent, and a staff representative of the Department to establish an understanding among the parties as to the items specified in the special and general conditions of the permit. The proposed locations of the structures shall be staked out for the conference. **Contact Jason Spanier at (772) 919-5786 or email jason.spanier@floridadep.gov to schedule a preconstruction conference.**
2. Prior to the commencement of construction activity authorized by this permit, a temporary construction fence shall be erected along the perimeter of the permitted area. The fence shall remain in place until the construction authorized by this permit is complete. The optimal placement of the construction fence shall be determined during the preconstruction conference by the staff representative, ensuring maximum protection of the existing native vegetation and dune features on the site.
3. All rubble, debris, wood, posts, piles and damaged or broken concrete resulting from this construction shall be removed and relocated landward of the coastal construction control line.
4. All sandy material excavated seaward of the control line shall be maintained on site seaward of the control line.
5. Any imported fill material shall be obtained from a source landward of the control line. All fill material (both excavated from the site and imported) shall consist of sand which is similar to that already on the site in both grain size and coloration and shall meet the requirements of Rule 62B-33.005(7), F.A.C. This fill material shall be free of construction debris, rocks, or other foreign matter. A sample of the sand shall be provided to the staff representative during the preconstruction conference.

6. Plantings shall conform to the approved planting plan. Removal of invasive plant species and landscape and dune enhancement plant installation shall not cause the removal of existing salt-tolerant native vegetation.
7. A preconstruction conference shall be held prior to the electrical rough-in for installation of exterior lights, and include the electrician or electrical contractor, the owner or authorized agent and staff representatives of the Department and the FWC. The Permittee shall contact the FWC at MarineTurtle@MyFWC.com for scheduling the conference, providing at least five (5) business days advance notice prior to the conference. A copy of the permitted exterior lighting plan shall be made available on site for the meeting and shall remain on site for consultation during the electrical installation. Requests to modify the approved exterior lighting plan will not be approved during or after the preconstruction meeting except as specified in the special conditions of this permit. Provisions shall be made for FWC staff to attend virtually or by phone. If the electrician or electrical contractor responsible for the installation of exterior lights is not available for the initial preconstruction conference, a construction conference shall be held at the site among the parties identified above prior to commencement of construction for any exterior lighting authorized by this permit.
8. All permanent exterior lighting shall be installed and maintained as depicted on the approved lighting drawings, tables and cut sheets stamped by FWC staff, signed, and dated 03.09.2026. No substitutions, alterations, or modifications to the approved lighting plan are allowed. Additional exterior lighting (permanent or temporary, including, but not limited to, construction, special event lighting, etc.) is prohibited on any structure or in the landscape within the project area unless otherwise authorized by FWC in an approved lighting plan. If during construction, an approved fixture or lamp needs to be changed to a different type, manufacturer, or catalog number for any reason, or if the location of any approved fixture needs to be changed, it shall be submitted for review and approval by the Department and the FWC prior to installation. There may be a decrease in the wattage of an approved lamp and/or a decrease in the total number of each approved fixture without submitting a modified lighting plan for review and approval.
9. The Permittee shall arrange for a site inspection by the FWC representative(s) within thirty (30) days of the completion of all construction activities, including the installation of all exterior lights, by sending notification to MarineTurtle@MyFWC.com. The Permittee agrees to allow access to the site for the FWC representatives to conduct day and nighttime exterior light site inspections upon 48-hour notice of the intent to inspect. If any of the lights become visible from the nesting beach at any time during the duration of this permit, they may be required to be modified.
10. All activity shall be confined to daylight hours. No temporary lighting of the construction area is authorized at any time during the marine turtle nesting season.
11. In accordance with F.A.C. 62B-33.0155(1)(n), the use of tinted glass or window film with a maximum visible light transmittance value of 45% or less shall be installed for all non-opaque doors, windows, walls, balconies, deck railings, and windows visible from any point on the beach, including seaward and lateral sides of the structure. It should be noted that darker tints that restrict light transmittance up to 15% are the best option for minimizing adverse impacts to marine turtles.
12. If any of the lights become visible from the beach, they may be required to be modified or removed such that they are no longer visible from the beach.

13. No construction, operation, transportation, or storage of equipment or materials is authorized during March 1 through October 31 on any part of the sandy beach or on or seaward of the frontal dune.
14. To reduce the risk of marine turtle entrapment, walkover structures shall have three (3) feet of vertical clearance beneath them and at least five (5) feet of horizontal clearance where they meet the beach. The vertical clearances include support bracing, as well as stairs and ramps. The horizontal clearances include between support pilings, and between stair blocking and pilings. Where these clearances cannot be met (such as under the stairs or ramp), blocking with appropriate materials shall be used to preclude marine turtle, including hatchling, access. Appropriate methods to block marine turtles include solid boards or planks with no more than one inch spacing. The blocking material shall be buried a minimum of one foot into the sand and be properly secured to the bottom of the walkover and support posts. These clearances shall be maintained if the elevation of the beach rises or lowers after construction. If adjacent to a bulkhead, structures shall be constructed as close to the bulkhead as possible (less than a foot) to avoid entrapment between pilings and the bulkhead.
15. The final certification report (DEP Form No. 73-115B) shall include a statement from the project engineer, architect, or lighting designer that all permanent exterior lighting has been installed as depicted on stamped, approved lighting schematic and cut sheets approved by FWC staff on 03.09.2026. A copy of the report on this form that is submitted to the Department shall also be submitted to the FWC by email to MarineTurtle@MyFWC.com.
16. Permittee shall submit compliance reports as specified in Special and General Permit Conditions of this permit. General Permit Conditions 1(q) and 1(r) pertain to written reports which must be submitted to the Department of Environmental Protection at specified times. The forms for the reports: 1(q) **Foundation Location Certification** (DEP Form 73-114B) and 1(r) **Final Certification** (DEP Form 73-115B) are available at the website: <https://floridadep.gov/rcp/coastal-construction-control-line/content/coastal-construction-control-line-cccl-forms>. Each form may be submitted electronically to the CCCL mailbox at CCCL@dep.state.fl.us.

GENERAL PERMIT CONDITIONS:

(1) The following general permit conditions shall apply, unless waived by the Department or modified by the permit:

(a) The permittee shall carry out the construction or activity for which the permit was granted in accordance with the plans and specifications that were approved by the Department as part of the permit. Deviations therefrom, without written approval from the Department, shall be grounds for suspension of the work and revocation of the permit pursuant to section 120.60(7), F.S., and shall result in assessment of civil fines or issuance of an order to alter or remove the unauthorized work, or both. No other construction or activities shall be conducted. No modifications to project size, location, or structural design are authorized without prior written approval from the Department. A copy of the notice to proceed shall be conspicuously displayed at the project site. Approved plans shall be made available for inspection by a Department representative.

(b) The permittee shall conduct the construction or activity authorized under the permit using extreme care to prevent any adverse impacts to the beach and dune system, marine turtles, their nests and habitat, or adjacent property and structures.

(c) The permittee shall allow any duly identified and authorized member of the Department to enter upon the premises associated with the project authorized by the permit for the purpose of ascertaining compliance with the terms of the permit and with the rules of the Department until all construction or activities authorized or required in the permit have been completed and all project performance reports, certifications, or other documents are received by the Department and determined to be consistent with the permit and approved plans.

(d) The permittee shall hold and save the State of Florida, the Department, and its officers and employees harmless from any damage, no matter how occasioned and no matter what the amount, to persons or property that might result from the construction or activity authorized under the permit and from any and all claims and judgments resulting from such damage.

(e) The permittee shall allow the Department to use all records, notes, monitoring data, and other information relating to construction or any activity under the permit, which are submitted, for any purpose necessary except where such use is otherwise specifically forbidden by law.

(f) Construction traffic shall not occur and building materials shall not be stored on vegetated areas seaward of the control line unless specifically authorized by the permit. If the Department determines that this requirement is not being met, positive control measures, such as temporary fencing, designated access roads, adjustment of construction sequence, or other requirements, shall be provided by the permittee at the direction of the Department. Temporary construction fencing shall not be sited within marine turtle nesting habitats.

(g) The permittee shall not disturb existing beach and dune topography and vegetation except as expressly authorized in the permit. Before the project is considered complete, any disturbed topography or vegetation shall be restored as prescribed in the permit with suitable fill material or revegetated with appropriate beach and dune vegetation. When required for mitigation, dune vegetation will be considered successfully established if within 180 days of planting, a minimum of 80 percent of the planting units survive, a minimum of 80 percent of the planted area is covered with native species and the vegetation is continuous without gaps along the shoreline.

(h) All fill material placed seaward of the CCCL shall meet the requirements of subsection 62B-33.005(7), F.A.C. All such fill material shall be free of construction debris, rocks, clay, or other foreign matter; and shall be obtained from a source landward of the CCCL.

(i) If surplus sand fill results from any approved excavation seaward of the control line, such material shall be distributed seaward of the control line on the site, as directed by the Department, unless otherwise specifically authorized by the permit. Sand fill placed seaward of the frontal dune, bluff or coastal armoring in marine turtle nesting habitat shall be configured such that it does not interfere with marine turtle nesting.

(j) Any native salt-tolerant vegetation destroyed during construction shall be replaced with plants of the same species or, by authorization of the Department, with other native salt-tolerant vegetation suitable for beach and dune stabilization. Unless otherwise specifically authorized by the Department, all plants installed in beach and coastal areas – whether to replace vegetation displaced, damaged, or destroyed during construction or otherwise – shall be of species indigenous to Florida beaches and dunes, such as sea oats, sea grape, saw palmetto, panic grass, saltmeadow hay cordgrass, seashore saltgrass, and railroad vine, and grown from stock indigenous to the region in which the project is located.

(k) All topographic restoration and revegetation work is subject to approval by the Department, and the status of restoration shall be reported as part of the final certification of the actual work performed.

(l) If not specifically authorized elsewhere in the permit, no operation, transportation, or storage of equipment or materials is authorized seaward of the dune crest or rigid coastal structure during the marine turtle nesting season. The marine turtle nesting season is May 1 through October 31 in all counties except Brevard, Indian River, St. Lucie, Martin, Palm Beach, and Broward counties where leatherback turtle nesting occurs during the period of March 1 through October 31.

(m) If not specifically authorized elsewhere in the permit, no temporary lighting of the construction area is authorized at any time during the marine turtle nesting season and no additional permanent exterior lighting is authorized.

(n) All non-opaque walls, balcony railings, deck railings, windows and doors visible from any point on the beach must be tinted to a transmittance value (light transmission from inside to outside) of 45 percent or less through the use of tinted glass or window film.

(o) The permit has been issued to a specified property owner and is not valid for any other person unless formally transferred. An applicant requesting transfer of the permit shall sign the permit transfer agreement form, agreeing to comply with all terms and conditions of the permit, and return it to the Department. The transfer request shall be provided on the form entitled “Permit Transfer Agreement” – DEP Form 73-103

(Revised 1/04), which is hereby adopted and incorporated by reference. No work shall proceed under the permit until the new owner has received a copy of the transfer agreement approved by the Department. A copy of the transfer agreement shall be displayed on the construction site along with the permit. An expired permit shall not be transferred. Copies of the "Permit Transfer Agreement" form are available at the following website: <http://www.dep.state.fl.us/beaches/forms.htm#CCCL>

(p) The permittee shall immediately inform the Department of any change of mailing address of the permittee and any authorized agent until all requirements of the permit are met.

(q) For permits involving habitable major structures, all construction on the permitted structure shall stop when the foundation pilings have been installed. At that time the foundation location form shall be submitted to and accepted by the Department prior to proceeding with further vertical construction above the foundation. The form shall be signed by a professional surveyor, licensed pursuant to chapter 472, F.S., and shall be based upon such surveys performed in accordance with chapter 472, F.S., as are necessary to determine the actual configuration and dimensioned relationship of the installed pilings to the control line. The information shall be provided to the Department using the form entitled "Foundation Location Certification" – DEP Form 73-114B (Revised 9/05), which is hereby adopted and incorporated by reference. Phasing of foundation certifications is acceptable. The Department shall notify the permittee of approval or rejection of the form within seven (7) working days after staff receipt of the form. All survey information upon which the form is based shall be made available to the Department upon request. Permits for repairs or additions to existing structures with nonconforming foundations are exempt from this condition.

(r) For permits involving major structures and exterior lighting on major structures, the permittee shall provide the Department with a report by a registered professional within 30 days following completion of the work. For permits involving armoring or other rigid coastal structures, the permittee shall provide the Department with a report by an engineer licensed in the State of Florida within 30 days following completion of the work. The report shall state that all locations specified by the permit have been verified and that other construction and activities authorized by the permit, including exterior lighting, have been performed in compliance with the plans and project description approved as a part of the permit and all conditions of the permit; or shall describe any deviations from the approved plans, project description, or permit conditions, and any work not performed. Such report shall not relieve the permittee of the provisions of paragraph 62B-33.0155(1)(a), F.A.C. If none of the permitted work is performed, the permittee shall inform the Department in writing no later than 30 days following expiration of the permit. The report shall be provided on the form entitled "Final Certification" DEP Form 73-115B (Revised 9/05), which is hereby adopted and incorporated by reference. Copies of the "Final Certification" form are available at the following website: <http://www.dep.state.fl.us/beaches/forms.htm#CCCL>

(s) Authorization for construction of armoring or other rigid coastal structures is based on an engineering review and assessment of the design and anticipated performance and impact of the structure as a complete unit. Construction of any less than the complete structure as approved by the Department is not authorized and shall result in the assessment of an administrative fine and the issuance of an order to remove the partially constructed structure. Modifications to the project size, location, or structural design shall be authorized by the Department in accordance with rule 62B-33.013, F.A.C.

(2) The permittee shall not commence any excavation, construction, or other physical activity on or encroaching on the sovereignty land of Florida seaward of the mean high water line or, if established, the erosion control line until the permittee has received from the Board of Trustees of the Internal Improvement Trust Fund the required lease, license, easement, or other form of consent authorizing the proposed use.

(3) The permittee shall obtain any applicable licenses or permits required by Federal, state, county, or municipal law.

(4) This permit does not authorize trespass onto other property.

(5) In the event of a conflict between a general permit condition and a special permit condition, the special permit condition shall prevail.

(6) Copies of any forms referenced above can be obtained by contacting the Department of Environmental

Protection, 2600 Blair Stone Road, MS 3522, Tallahassee, Florida 32399-2400, at <http://www.dep.state.fl.us/beaches/forms.htm#CCCL> or by telephoning (850) 245-8570.

CAVEAT:

Due to potential adverse impacts to the beach and dune system that may result from additional development on the property, the shore-parallel and seaward extent of the permitted structures shall not be increased, nor will any additional major structures be permitted which would exceed the limits established by the permitted construction seaward of the coastal construction control line.

Approved plans are incorporated into this permit by reference.

NOTICE OF RIGHTS

This action is final and effective on the date filed with the Clerk of the Department unless a petition for an administrative hearing is timely filed under Sections 120.569 and 120.57, F.S., before the deadline for filing a petition. On the filing of a timely and sufficient petition, this action will not be final and effective until further order of the Department. Because the administrative hearing process is designed to formulate final agency action, the hearing process may result in a modification of the agency action or even denial of the application.

Petition for Administrative Hearing

A person whose substantial interests are affected by the Department's action may petition for an administrative proceeding (hearing) under Sections 120.569 and 120.57, F.S. Pursuant to Rules 28-106.201 and 28-106.301, F.A.C., a petition for an administrative hearing must contain the following information:

- (a) The name and address of each agency affected and each agency's file or identification number, if known;
- (b) The name, address, and telephone number of the petitioner; the name, address, and telephone number of the petitioner's representative, if any, which shall be the address for service purposes during the course of the proceeding; and an explanation of how the petitioner's substantial interests are or will be affected by the agency determination;
- (c) A statement of when and how the petitioner received notice of the agency decision;
- (d) A statement of all disputed issues of material fact. If there are none, the petition must so indicate;
- (e) A concise statement of the ultimate facts alleged, including the specific facts that the petitioner contends warrant reversal or modification of the agency's proposed action;
- (f) A statement of the specific rules or statutes that the petitioner contends require reversal or modification of the agency's proposed action, including an explanation of how the alleged facts relate to the specific rules or statutes; and
- (g) A statement of the relief sought by the petitioner, stating precisely the action that the petitioner wishes the agency to take with respect to the agency's proposed action.

The petition must be filed (received by the Clerk) in the Office of General Counsel of the Department at 3900 Commonwealth Boulevard, Mail Station 35, Tallahassee, Florida 32399-3000, or via electronic correspondence at Agency_Clerk@dep.state.fl.us. Also, a copy of the petition shall be mailed to the applicant at the address indicated above at the time of filing.

Time Period for Filing a Petition

In accordance with Rule 62-110.106(3), F.A.C., petitions for an administrative hearing by the applicant and persons entitled to written notice under Section 120.60(3), F.S., must be filed within 21 days of receipt of this

written notice. Petitions filed by any persons other than the applicant, and other than those entitled to written notice under Section 120.60(3), F.S., must be filed within 21 days of publication of the notice or within 21 days of receipt of the written notice, whichever occurs first. The failure to file a petition within the appropriate time period shall constitute a waiver of that person's right to request an administrative determination (hearing) under [Sections 120.569](#) and 120.57, F.S., or to intervene in this proceeding and participate as a party to it. Any subsequent intervention (in a proceeding initiated by another party) will be only at the discretion of the presiding officer upon the filing of a motion in compliance with Rule 28-106.205, F.A.C.

Extension of Time

Under Rule 62-110.106(4), F.A.C., a person whose substantial interests are affected by the Department's action may also request an extension of time to file a petition for an administrative hearing. The Department may, for good cause shown, grant the request for an extension of time. Requests for extension of time must be filed with the Office of General Counsel of the Department at 3900 Commonwealth Boulevard, Mail Station 35, Tallahassee, Florida 32399-3000, or via electronic correspondence at Agency_Clerk@dep.state.fl.us, before the deadline for filing a petition for an administrative hearing. A timely request for extension of time shall toll the running of the time period for filing a petition until the request is acted upon.

Mediation

Mediation is not available in this proceeding.

Judicial Review

Once this decision becomes final, any party to this action has the right to seek judicial review pursuant to Section 120.68, F.S., by filing a Notice of Appeal pursuant to Florida Rules of Appellate Procedure 9.110 and 9.190 with the Clerk of the Department in the Office of General Counsel (Station #35, 3900 Commonwealth Boulevard, Tallahassee, Florida 32399-3000) and by filing a copy of the Notice of Appeal accompanied by the applicable filing fees with the appropriate district court of appeal. The notice must be filed within 30 days from the date this action is filed with the Clerk of the Department.

EXECUTION AND CLERKING

Executed in Tallahassee, Florida.

STATE OF FLORIDA DEPARTMENT OF ENVIRONMENTAL PROTECTION



Aline Sartori, Environmental Specialist III
Coastal Construction Control Line Program
Office of Resilience and Coastal Protection

CERTIFICATE OF SERVICE

The undersigned duly designated deputy clerk hereby certifies that this document and all attachments were sent on the filing date below to the following listed persons:

William Stoddard, Ph.D., P.E., Agent, wstoddard@sbsengineers.com
Kacey Bladergroen, Agent, kbladergroen@sbsengineers.com
Jason Spanier, Field Inspector, jason.spanier@floridadep.gov

PERMITTEE: Vitae Advisors, LLC
PERMIT NUMBER: IR001100
PAGE 10

FILING AND ACKNOWLEDGMENT

FILED, on this date, pursuant to Section 120.52, F. S., with the designated Department Clerk, receipt of which is hereby acknowledged.



Clerk

03/17/2026
Date

FWC Best Management Practices for Protected Shorebirds and Seabirds

The Florida Fish & Wildlife Conservation Commission (FWC) has the authority to protect shorebirds and seabirds in accordance with Article IV, Section 9 of the Florida Constitution, 372.021, Florida Statutes, and 68A-1.002, Florida Administrative Code. Shorebirds and seabirds listed as state-Threatened Species under 68A-27.003(2)(a) F.A.C. (i.e. least tern, black skimmer, snowy plover, American oystercatcher) are protected from “take” (harm and harassment) as defined in 68A-27.001(4) F.A.C. Shorebirds and seabirds listed under the federal Migratory Bird Treaty Act are protected under 16 U.S.C. Sections 703-712 (adopted in state rule 68A-16.001, F.A.C.).

Please utilize the Imperiled Beach-nesting Bird (IBNB) [ShoreMapper Tool](https://gis.myfwc.com/ShoreMapper/) (<https://gis.myfwc.com/ShoreMapper/>) to determine if a Recent Breeding Site or Critical Brood-rearing Site is present near your project area. The FWC [Regional Shorebird Contact](#) can help determine if there are any Active Breeding Sites near your project.

CCCL permitted activities can result in harm and harassment of these species when activities occur during shorebird breeding season (Mar. 1 - Sept. 1 on Florida’s east coast; Feb. 15 - Sept. 1 on west coast). Harm and harassment can be avoided by providing at least a 300-ft. buffer between project activities and “active nests” as defined in FWC Species Conservation Measures and Permitting Guidelines for Imperiled Beach-nesting Birds (IBNB Guidelines, <https://myfwc.com/wildlifehabitats/wildlife/species-guidelines/>). If the recommended buffers cannot be maintained, harm or harassment is likely to occur, and authorization may be needed from the FWC *prior to commencement of the activity*.

If your CCCL permitted activity will result in harm to IBNBs via “Significant Habitat Modification” (as defined in Guidelines) within a Recent Breeding Site or Critical Brood-rearing Site, an incidental take permit is recommended *prior to commencing the activity, regardless of when the activity occurs during the year*.

Contact the Regional Shorebird Contact for your area to discuss ways to avoid take or for more information on FWC incidental take permits: <https://myfwc.com/conservation/you-conserve/wildlife/shorebirds/contacts/>.

Even if the project area is not within 300 feet of Recent Breeding Sites/Critical Brood-rearing Sites in [ShoreMapper](#), new breeding activity could occur near your project. To avoid take, permittees should:

- a. Arrange for a qualified monitor to conduct nesting surveys prior to project commencement and each day prior to project activities during shorebird breeding season (<https://myfwc.com/conservation/you-conserve/wildlife/shorebirds/contacts/>). You may choose to employ an IBNB Permitted Monitor to conduct surveys. For a list of permitted monitors, visit <https://myfwc.com/license/wildlife/ibnb/> or for more information on IBNB Permitted Monitors visit <https://myfwc.com/license/wildlife/ibnb/permitted-monitors/>. Note that although most breeding activity is complete by the end of shorebird breeding season (Sept. 1), flightless chicks may be present beyond this date.
 - i. Surveys for detecting nesting activity should be completed prior to movement of equipment, operation of vehicles, or other activities that could potentially disrupt breeding behavior or cause harm to birds, eggs or young.
 - ii. The person conducting the CCCL permitted activity should not serve as the monitor while conducting the activity.
 - iii. Surveys should continue until the project is completed or the end of breeding season (whichever is first).
 - iv. If you observe a nest scrape, active nest, or shorebird young within 300 feet of project boundaries, stop work immediately and notify the appropriate [FWC Regional Shorebird Contact](#) within 24 hours. **FWC authorization may be needed to avoid a wildlife violation of 68A-27 FAC.**

- b. Where breeding has been reported or observed, work with [FWC staff](#) to post the perimeter of buffer zones with clearly marked signs.

Mechanical Beach Cleaning

Beach Cleaning within 300 feet of an Active or Recent Breeding Site during breeding season, or within 300 feet of an Active Critical Brood Rearing site (Mar 15-Sep 1) is likely to cause take. FWC may authorize take without an FWC incidental take permit in some cases, provided the requirements below are followed. Contact your Regional Shorebird Contact for more information about authorizations and requirements below.

- At least one individual (“shorebird monitor”) must complete the [online training](#) available on FWC’s eLearning website (available at <https://myfwc.com/license/wildlife/ibnb/resources/#training>).
 - Module 1: Qualifications, Species ID, Nesting Behavior and Habitats.
 - Module 2: Breeding Activity Checks, Monitoring and Reporting Requirements.
 - Module 3: Active Breeding Sites: Posting and Protection.
- This monitor must carry their certificate of completion while conducting surveys.
- Prior experience conducting at least 3 surveys that involve observations of Active Nests of Imperiled Beach-nesting Birds (IBNBs) is recommended but not required.
- Individuals conducting beach cleaning must carry an FWC written authorization for take when conducting activities within 300 feet of active nests.
- Monitors and beach cleaners must review [IBNB Minimization Measures Training for Vehicle Operation](#) (<https://myfwc.com/license/wildlife/ibnb/resources/>).
- Prior to conducting mechanical beach cleaning, surveys for active nests and flightless chicks of IBNBs must be conducted on foot by the shorebird monitor using binoculars. In areas where flightless chicks are present, this monitor must be present during beach cleaning activities to prevent chicks from being killed or injured and must not be the person operating mechanical cleaning equipment.
- Surveys conducted for mechanical beach cleaning should **not** be submitted to the Florida Shorebird Database.
- Mechanical Beach Cleaner must notify the Regional Shorebird Contact within 24 hours if any new nests are found.
- Active breeding must be posted with protective signage and according to the [Guidelines for Posting Shorebird and Seabird Sites in Florida](#)” (<https://flshorebirdalliance.org/resources/instructions-resources/>) prior to mechanical beach cleaning.
- Mechanical Beach Cleaning within 300 feet of an active breeding site or within 300 feet of an Active Critical Brood Rearing site must occur in the early morning (i.e., within 2 hours of sunrise) or evening (i.e., within 1 hour of sunset) to minimize the exposure of eggs and chicks to heat and sun.
- It is recommended that a minimum of thirty percent (30%) of the natural seaweed wrack be left on the beach at least through the breeding season (year-round, if possible) to provide foraging habitat for nesting, wintering, and migrating shorebirds.

Note: these BMPs are intended to help ensure CCCL permit holders are in compliance with regulations that protect imperiled shorebirds. Adherence to these BMPs is not subject to enforcement under Sections 161.052 or 161.053, Florida Statutes.



AGENDA ITEM

TO: Town Council
James Harpring, Town Manager

FROM: Janice C. Rutan, Town Clerk

DATE: April 10, 2026

SUBJECT: Resolution No. 26-02 Cemetery Fees

BACKGROUND:

The Town Clerk is responsible for managing John’s Island Cemetery. Administrative and operational procedures have recently been enacted for cemetery management. This includes increased staff time in the field, along with coordination with families and funeral homes.

It is proposed that the fee schedule be amended as outlined in Resolution No. 26-02 to accurately reflect management and operational costs.

Proposed Fees:

The costs to open and close cemetery lots be set as follows:

Monday through Friday:	\$250.00
Saturdays, Sundays and Holidays	\$400.00

RECOMMENDATION:

Approve Resolution No. 26-02 Cemetery Fees

ATTACHMENTS:

Resolution No. 26-02



RESOLUTION NO. 26-02

A RESOLUTION OF THE TOWN COUNCIL OF THE TOWN OF INDIAN RIVER SHORES, FLORIDA, AMENDING THE CEMETERY FEE SCHEDULE FOR OPENING AND CLOSING OF LOTS AND ADMINISTRATIVE COSTS; AND PROVIDING FOR AN EFFECTIVE DATE

WHEREAS, The Town of Indian River Shores manages the John's Island Cemetery; and

WHEREAS, Ordinance No. 557, adopted by the Town Council on March 30, 2023 further states that all costs, including administrative fees should be established by Resolution of the Town Council;

NOW THEREFORE BE IT RESOLVED, that said costs to manage the John's Island Cemetery should not be borne by the Town, but should be self-sufficient and include costs to cover the perpetual care of the cemetery;

NOW THEREFORE BE IT FURTHER RESOLVED as follows:

SECTION 1. The costs to open and close cemetery lots be set as follows:

Monday through Friday:	\$250.00
Saturdays, Sundays and Holidays	\$400.00

SECTION 2. In addition to the above prices, the Town Clerk is hereby authorized to establish charges and fees for any other requested services based on the Town's prevailing costs for labor, materials, overhead and administration.

SECTION 3. This Resolution shall take effect immediately upon its adoption.

Passed and duly adopted by the Town Council of Indian River Shores at a Regular Town Council meeting held on the 23rd day of April 2026.

Brian T. Foley, Mayor

ATTEST:

Janice C. Rutan, Town Clerk



AGENDA ITEM

TO: Town Council

FROM: James Harpring, Town Manager

DATE: April 16, 2026

SUBJECT: Interlocal Agreement (ILA) – Indian River County
Local Option Gas Tax (LOGT)

BACKGROUND:

Florida Statutes Section 336.025 grants the County authority to levy a local option gas tax on every gallon of motor fuel and special fuel sold in the County and taxed under Chapter 206, Florida Statutes. Consistent with that section and as a municipality in Indian River County, the Town is eligible to receive a portion of the local gas tax. The County and municipalities established a distribution formula pursuant to Section 336.205(3)(a)(1) and outlined in the ILA.

The ILA approved by Council at the February 17, 2026 meeting has been revised to include an updated formula for distribution. It is scheduled for approval by the Indian River County Board of County Commissioners at the May 2026 Commissioner Meeting.

RECOMMENDATION:

Approve the revised Interlocal Agreement for Optional Gas Tax Distribution

ATTACHMENTS:

Interlocal Agreement for Optional Gas Tax Distribution between Indian River County and the Town of Indian River Shores.

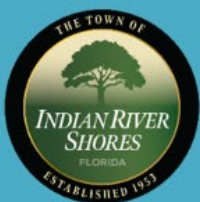

INTERLOCAL AGREEMENT FOR OPTIONAL GAS TAX DISTRIBUTION

Between

INDIAN RIVER COUNTY, FLORIDA

And

TOWN OF INDIAN RIVER SHORES

THIS INTERLOCAL AGREEMENT, entered into this ____ day of _____, 2026, by and between INDIAN RIVER COUNTY, FLORIDA, a political subdivision of the state of Florida, by and through its Board of County Commissioners, hereinafter referred to as COUNTY and the TOWN OF INDIAN RIVER SHORES, a municipal corporation of the State of Florida, hereinafter referred to as TOWN, for the purpose of providing for the division and distribution of the proceeds of the local option gas tax imposed by the COUNTY pursuant to Florida Statutes Section 336.025.

WITNESSETH:

WHEREAS, Florida Statutes Section 336.025 grants the COUNTY the authority to levy, in addition to other taxes allowed by law, a local option gas tax upon every gallon of motor fuel and special fuel sold in the COUNTY and taxed under the provisions of Chapter 206, Florida Statutes; and

WHEREAS, pursuant to said enactment, the COUNTY may establish by interlocal agreement with one or more of the municipalities located within the COUNTY representing a majority of the incorporated area population within the county, a distribution formula for dividing the proceeds of the local option gas tax among the COUNTY government and all eligible municipalities within the COUNTY; and

WHEREAS, the TOWN is a municipality located within Indian River County, Florida and the TOWN represents that the TOWN is eligible to receive a portion of the local gas tax as imposed by the Indian River County Local Option Gas Tax Ordinance, and desires to jointly establish with the COUNTY a distribution formula pursuant to Florida Statutes Section 336.025(3)(a)(1).

NOW, THEREFORE, in consideration of the mutual terms, conditions, promises, covenants and premises hereinafter set forth pursuant to the statutory authority set forth herein, the COUNTY and the TOWN agrees as follows:

1. The proceeds of the local gas tax shall be divided among and distributed to the COUNTY and the eligible municipalities within the COUNTY as follows:

<u>RECIPIENT</u>	<u>SHARE OF PROCEEDS</u>
Indian River County	70.316039%
City of Vero Beach	9.723878%
City of Fellsmere	2.756476%
City of Sebastian	15.472814%
Town of Orchid	0.291454%
Town of Indian River Shores	1.439338%

2. The division and distribution of tax proceeds as stated in paragraph 1 above shall be based upon the following formula:

1/2 of the entity's percentage of total equivalent lane miles of road plus 1/2 of the entity's total percentage of population based upon most recent estimate from the University of Florida Bureau of Economic and Business Research (BEBR). Said formula shall be reviewed every two years with each municipality reporting the items noted above to the Public Works Director by April 30th with a public hearing following in May to discuss and adopt the distribution formula that the County will provide to the Florida State Department of Revenue and will take effect starting September 1, 2028. Recalculation of the distribution shall be the only portion of the agreement subject to change every two years at the two-year review.

3. This agreement shall take effect on September 1, 2026, and shall terminate on August 31, 2056. This agreement shall also govern the division and distribution of proceeds of the local option gas tax imposed through August 31st but not collected or otherwise available for distribution until after August 31st of the year the agreement terminates.

4. If, during the term of this agreement, any party hereto becomes ineligible to receive a share of the local option gas tax for any reason, any funds otherwise undistributed because of ineligibility shall be distributed to eligible governments within COUNTY in proportion to other

monies distributed pursuant to paragraph 1 herein and the share shall be calculated pursuant to the formula contained within paragraph 2 herein.

5. By execution of this agreement, neither the COUNTY nor the TOWN will be deemed to have waived any rights or remedies they may have available under the laws of the State of Florida.

6. This agreement shall be executed in duplicate and each fully executed contract shall be deemed an original instrument.

7. Upon adoption of an ordinance levying the local option gas tax by the COUNTY, the COUNTY shall provide the State of Florida Department of Revenue with the distribution proportions established by this agreement.

8. A copy of this agreement and all subsequent amendments hereto shall be recorded in the Public Records of Indian River County, Florida, upon its execution and all parties hereto.

9. This agreement may be amended only in writing with the approval of all parties executing this agreement.

IN WITNESS WHEREOF, the parties hereto have caused this interlocal agreement to be executed by their duly authorized officials on the day and year first above written.

INDIAN RIVER COUNTY, FLORIDA
By its BOARD OF COUNTY COMMISSIONERS

Chairman

Attested to by Ryan L. Butler,
Clerk of the Circuit Court and Comptroller

By : _____

Deputy Clerk

Approved as to Form and Legal Sufficiency

By: _____
Susan J. Prado, Deputy County Attorney

Town of Indian River Shores

Brian Foley, Mayor

Attest _____

Approved as to legal form and sufficiency:

Peter Sweeney, Town Attorney



AGENDA ITEM

TO: Town Council

FROM: James Harpring, Town Manager

DATE: April 13, 2026

SUBJECT: Work Authorization 2026-11 Kimley-Horn
Building Department Addition Design Services

BACKGROUND:

The Town seeks to use funds authorized under Section 553.80, Florida Statutes to expand Building Department offices. The expansion will provide for additional offices and workspace for staff to enhance the delivery of Building Department services to residents and contractors.

RECOMMENDATION:

Approve Work Authorization 2026-11

ATTACHMENTS:

Work Authorization 2026-11 – Building Department Addition Design Services by Kimley Horn.





THE TOWN OF
INDIAN RIVER SHORES

WORK AUTHORIZATION

Work Authorization Number: 2026-11

Project Name: Building Department Addition Design Services

Consultant: Kimley-Horn
445 24th Street Suite 200
Vero Beach, FL 32960
POC – Peter Van Rens
peter.vanrens@kimley-horn.com

SCOPE OF SERVICES

The Scope of Services contemplated under the Continuing Engineering Services Contract of August 11, 2023 is as follows:

Kimley-Horn shall provide professional engineering and architectural services for the Town's Building Department Addition project in support of the Town's planned competitive construction solicitation. Services shall include the following:

Project Coordination and Meetings: This task consists of Kimley-Horn's coordination with the Town's consultants or sub-consultants to address issues related to the project and effort to schedule the submittal of required applications and plans. This task will include administrative services as required to prepare permit application packages and will also include up to **20 hours** of coordination with assigned consultants consisting of geotechnical consultants, surveyors, and architects.

This task will also include effort associated with pre-application meetings and meeting request submittals with governing agencies listed below.

Pre-Application Meetings with the following:

- Florida Department of Transportation
- St. Johns River Water Management District

Should additional meetings be required they will be considered an additional service.

This task also consists of project invoicing and accounting services to be provided by Kimley-Horn. This task assumes the project administration and clerical scope of work would be performed over a period of **6 months**.

Preliminary Construction Documents: Kimley-Horn shall review readily available existing conditions information provided by the Town, consisting of record drawings, as-built documents, utility information, survey data, and geotechnical reports, as applicable and will prepare preliminary construction documents for regulatory permitting review. The following drawings are anticipated:

- Cover
- General Notes
- Demolition and Erosion Control Plan
- Erosion Control Details

- Site Plan
- Site Details
- Paving, Grading, Drainage Plan
- Paving, Grading, Drainage Details
- Utility Plan
- Utility Details
- Tree Mitigation and Inventory Plan
- Landscape Plan
- Landscape Details

In addition, the following calculation/report will be prepared:

1. On-Site Drainage Report for submittal to SJRWMD for the ERP permit application

Permitting: Kimley-Horn will prepare supporting documentation required for the submittal of permit applications. The following is a list of anticipated permits required to develop:

- Town of Indian River Shores – Site Plan
- Town of Indian River Shores – Building Department (Lead by EDB Architects)
- Town of Indian River Shores – Tree Removal
- Florida Department of Transportation – Drainage Connection Permit (Exemption)
- Florida Department of Environmental Protection – Water (Exemption)
- Florida Department of Environmental Protection – Sewer (Exemption)
- St. Johns River Water Management District – Environmental Resource Permit

Kimley-Horn will prepare permit applications and submit them to the above listed agencies. This proposal consists of responses to up to two (2) rounds of comments for each submittal listed above.

Permitting fees shall be the responsibility of the Town unless otherwise agreed in writing.

Final Construction Documents: Kimley-Horn will prepare updates to the approved preliminary plans to accommodate the construction of the proposed project. The following items are included:

Civil Sheets (Provided By Kimley-Horn)

- Cover
- General Notes
- Demolition and Erosion Control Plan
- Erosion Control Details
- Site Plan
- Site Details
- Paving, Grading, Drainage Plan
- Paving, Grading, Drainage Details
- Utility Plan
- Utility Details
- Tree Mitigation and Inventory Plan
- Landscape Plan
- Landscape Details

Architectural Construction Documents (Provided by EDB Architects and Associates)

Architectural documents shall address building layout, floor plans, elevations, building sections, exterior and

interior finishes, and life safety compliance in accordance with the Florida Building Code.

Opinion of Probable Construction Cost: Kimley-Horn shall prepare an opinion of probable construction cost based on the final civil construction documents. Kimley-Horn will retain EDB Architects and Associates P.A. to provide an opinion of probable cost based on the building expansion and interior improvements. The opinion is for informational purposes only and does not constitute a guarantee of actual construction costs.

Bidding Support: Kimley-Horn and EDB Architects and Associates P.A. shall provide limited support during the bidding phase, including responding to contractor questions, preparing addenda's, and attending a pre-bid conference if requested by the Town. **This task anticipates no more than 20 hours of effort.**

Limited Construction Phase Services:

This task shall consist of the anticipated routine periodic observations and construction phase assistance as part of the construction phase of the project.

Pre-Construction Conference: Consultant will conduct a Pre-Construction Conference with Town and Client's contractor before the start of construction.

Site Visits: Consultant shall provide on-site construction observation services during the construction phase. Consultant will make visits at intervals deemed necessary by the Consultant in order to observe the progress of the Work. Such visits and observations by Consultant are not intended to be exhaustive or to extend to every aspect of Contractor's work in progress. Observations are to be limited to spot checking, selective measurement, and similar methods of general observation of the Work based on Consultant's exercise of professional judgment. The intent of these observations is to allow the Consultant to certify the construction completion of water, sewer, drainage, and site work as required by the Agencies having jurisdiction. This task assumes that the Client will serve as their own construction manager and that Kimley-Horn is only involved as necessary to provide final certifications to the agencies. This task assumes the construction of this project will last **4 months and 2 site visits will be required per month.**

Consultant shall not, during such visits or as a result of such observations of Contractor's work in progress, supervise, direct, or have control over Contractor's work, nor shall Kimley-Horn have authority over or responsibility for the means, methods, techniques, equipment choice and usage, sequences, schedules, or procedures of construction selected by Contractor, for safety precautions and programs incident to Contractor's work, nor for any failure of Contractor to comply with laws and regulations applicable to Contractor's furnishing and performing the Work.

Accordingly, Consultant neither guarantees the performance of any Contractor nor assumes responsibility for any Contractor's failure to furnish and perform its work in accordance with the Contract Documents.

Recommendations with Respect to Defective Work: Consultant will recommend to Client that Contractor's work be disapproved and rejected while it is in progress if, on the basis of such observations, Consultant believes that such work will not produce a completed Project that conforms generally to Contract Documents.

Clarifications and Interpretations: Consultant will respond to reasonable and appropriate Contractor requests for information and issue necessary clarifications and interpretations of the Contract Documents to Client as appropriate to the orderly completion of Contractor's work. This task assumes up to **4 RFI's** will be responded to. Any orders authorizing variations from the Contract Documents will be made by Client.

Shop Drawings Review: Consultant shall review and approve or take other appropriate action in respect to Shop Drawings and other data which Contractor is required to submit, but only for conformance with the information

given in the Contract Documents. Such review and approvals or other action will not extend to means, methods, techniques, equipment choice and usage, sequences, schedules, or procedures of construction or to related safety precautions and programs. **This task anticipates 4 hours of effort.**

Review of As-Built Plans: Kimley-Horn will review the signed and sealed As-Built Plans as provided by the Contractor's professional registered surveyor for the Paving, Grading and Drainage Plan and Utility Plan for general compliance with the plans, specifications, and permit conditions. **This task anticipates 8 hours of effort.**

Preparation of Final Punchlist: Once As-builts are complete, Kimley-Horn will walk the site with the Contractor and Client and put together a final punch list of items that need to be addressed as a part of the final closeout. Upon request of the Client, and confirmation by the contractor that the "punch list" items have been completed, Kimley-Horn will provide one (1) site visit (in addition to those described above) to review the construction site civil for final completion and general compliance with the plans, specifications, and permit conditions. Kimley-Horn will prepare a memo notifying the Client that the work has been completed. **This task anticipates 8 hours of effort.**

Final Project Close Out:

Construction Certification of Completeness to Permitting Agencies: Upon satisfactory completion of the work and submittal of satisfactory as-built drawings by the contractor, Kimley-Horn will notify the permitting agencies that the project has been completed and that based on our periodic site observations and information provided by the contractor that the project has been constructed in general compliance with the approved site civil plans, specifications, and permit conditions. Kimley-Horn will note significant deviations from the plans, specifications, and permit conditions. **This task anticipates 20 hours of effort.**

Limitation of Responsibilities: Consultant shall not be responsible for the acts or omissions of any Contractor, or of any of their subcontractors, suppliers, or of any other individual or entity performing or furnishing the Work. Consultant shall not have the authority or responsibility to stop the work of any Contractor. Under no circumstances shall the Consultant be liable for lost profits or consequential damages, for extra costs or other consequences due to changed conditions, or for costs related to the failure of Contractors to perform work in accordance with the plans and specifications.

Architectural Services: Kimley-Horn will retain Edlund, Dritenbas, Binkley Architects and Associates P.A to provide architectural design for the project. The following will be provided by the sub-consultant:

The Architect shall provide full permit documents for construction. Documents and services provided by the Architect and his employed Structural, Mechanical, Electrical, and Plumbing Engineering sub-consultants will include the following:

- Data Collection, additional field verifications, and meetings as required.
- Established as-built AutoCAD floorplans based upon existing construction documents and field verifications.
- Construction documents for code compliance and remodeling
- Address plan review comments and make reasonable revisions.
- Assist in requesting construction bids, bidding administration., addendum as needed.
- Construction administration shall be for periodic construction observations twice monthly, RFI responses, submittals review, review of pay applications and any changes in the work. A punch list and final inspection will also be done

Deliverables: Kimley-Horn shall provide preliminary construction documents on May 13, 2026 and final signed and sealed construction documents in electronic PDF format and in an editable format customarily used by the Consultant once permits are issued. Deliverables shall be sufficiently complete for the Town to publicly advertise the project for competitive bidding through an Invitation to Bid.

Schedule: Kimley-Horn and EDB shall provide preliminary construction documents as described herein no later than May 13, 2026. Any delays caused by the Town's failure to provide requested information, Town-directed scope changes, or circumstances beyond Kimley-Horn's reasonable control shall not be counted against this deadline and may require a mutually agreed upon schedule adjustment.

Additional Services: Any services not specifically described herein shall be considered additional services and shall require prior written authorization by the Town before such services are performed.

Contract Price: \$115,000

By the signatures affixed below, the Town and the Consultant agree to the Scope of Services as described herein. Upon issuance of the Work Authorization to the Consultant by the Town, the Consultant shall begin work in a timely manner. The Scope of Services contemplated under this Work Authorization are hereby incorporated into, and made part of, the Continuing Services Agreement between the Town and the Consultant.

On Behalf of the Town:

On Behalf of Kimley-Horn and Associates Inc.:

James Harpring
Town Manager

Chris J. Hollen, P.E.
Vice President

Heather Christmas
Town Finance Director

Date: 04/21/2026

STUDY'S PURPOSE

To **evaluate and preserve coastal resources**, Indian River County adopted its **first Beach Preservation Plan (BPP)** in **1988**; periodic updates to the BPP have occurred in 1998, 2002, 2008, 2015, and 2019.

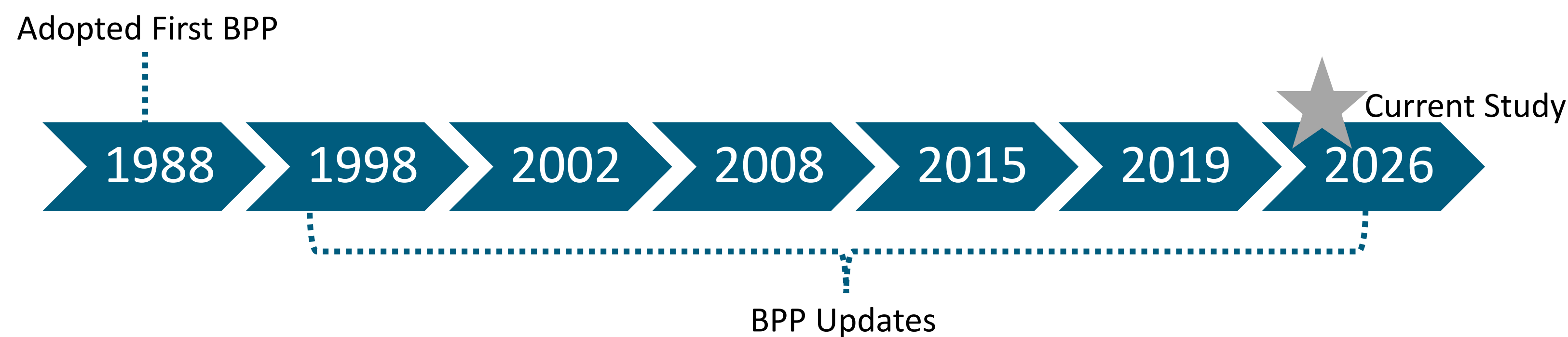

This 2026 update evaluates **current coastal conditions**, **assesses risks**, and **identifies management strategies** to guide resilient, long-term shoreline stewardship. Building on prior efforts, this BPP reflects the County's **proactive management approach and plan development** which lays the foundation for their successful beach management program that **enhances coastal resilience** while supporting the County's **economic vitality** and **environmental resources**.



COMMUNITY ENGAGEMENT & FEEDBACK

Thank you for joining us to learn more about the ongoing beach preservation plan update, please do not forget to:

1 Take the survey to provide meeting feedback



2 Read the report to learn more about the current study and beach management in Indian River County

3 Follow Indian River County to stay informed:

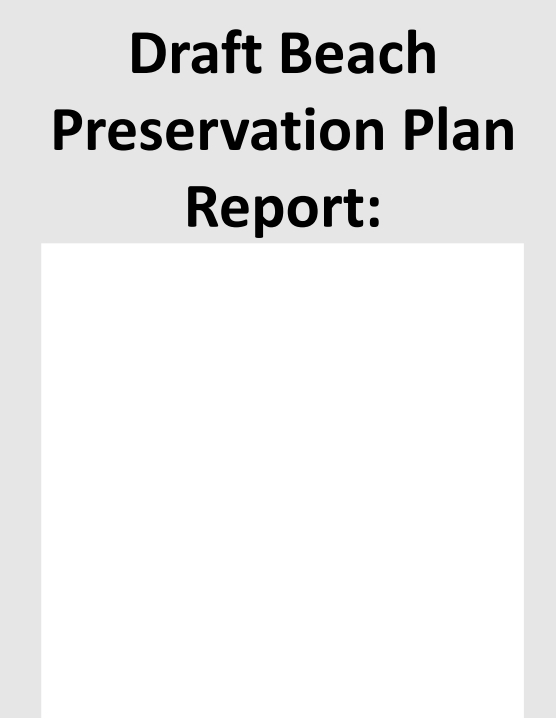

REPORT SNAPSHOT

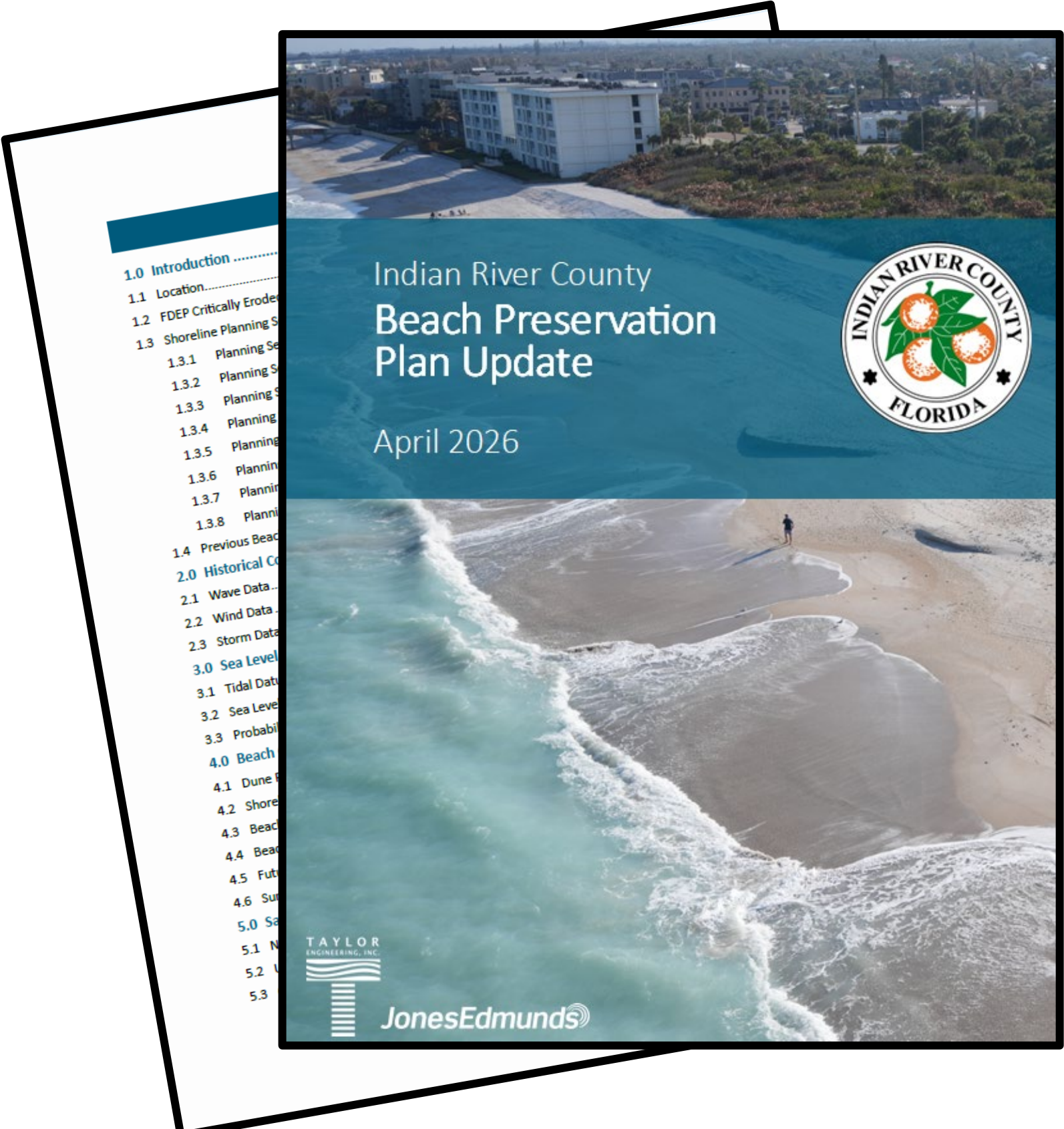
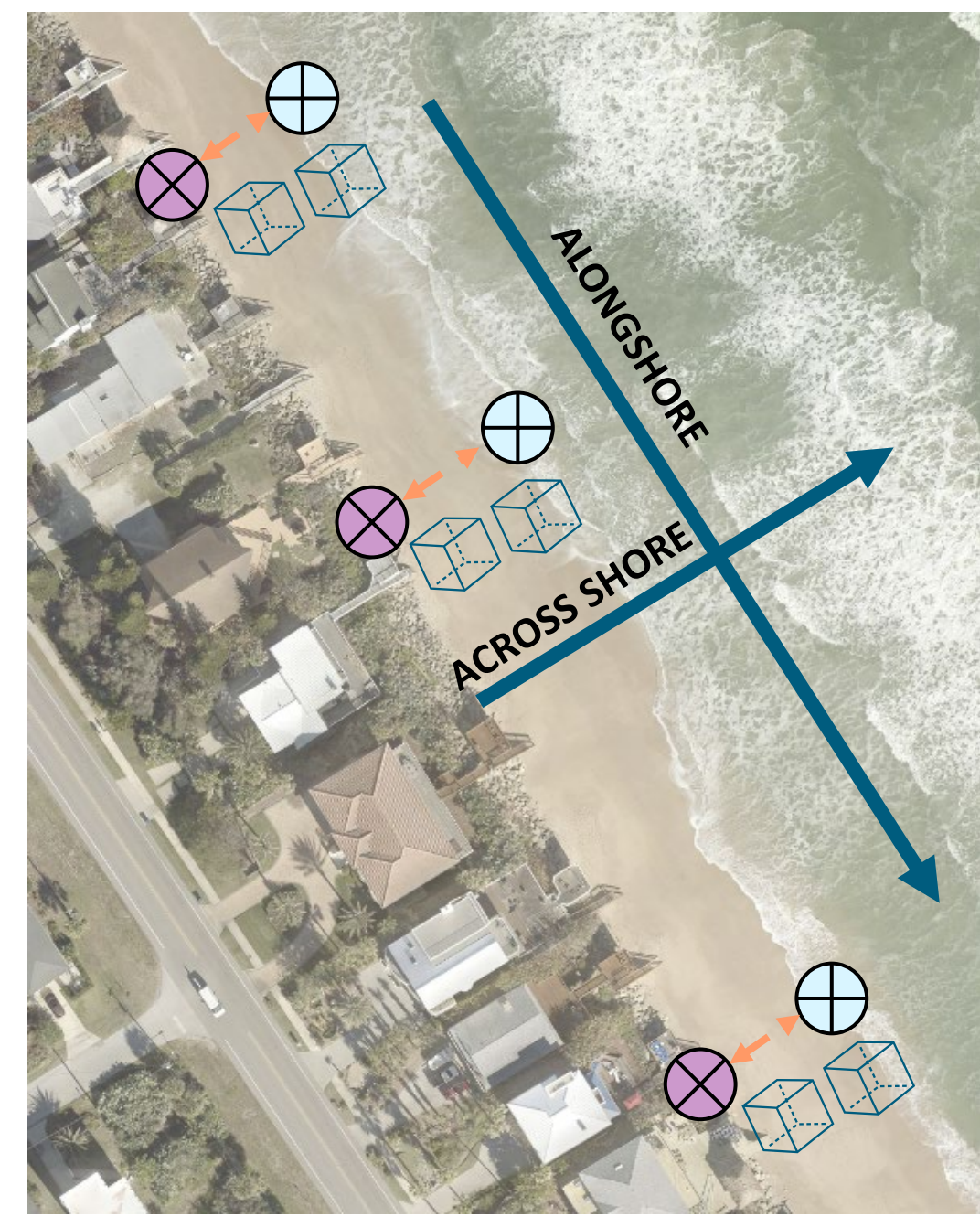
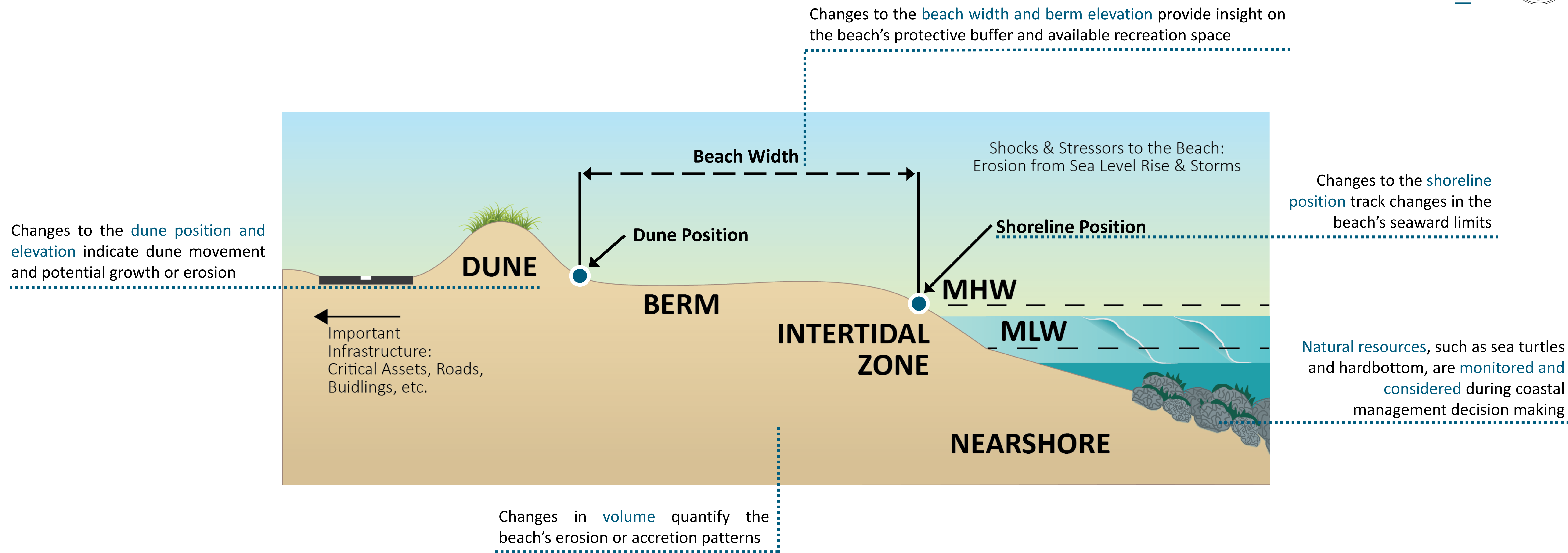

Table of Contents

1	Introduction	1
2	Historical Coastal Conditions	18
3	Sea Level Rise and Water Levels	25
4	Beach Conditions Update	32
5	Sand Resources	53
6	Environmental and Biological Resources	58
7	Beach Development and Its Economic Impact	66
8	Risk Analysis	71
9	Beach Management Strategies	86
10	Community Outreach	120
11	Summary and Recommendations	122
Appendix A	Historical Data Collection	
Appendix B	Previous Beach Preservation Plans and Studies	
Appendix C	Coastal Conditions, Water Levels, and Sea Level Rise	
Appendix D	Beach Condition Update	
Appendix E	Sand Resources	
Appendix F	Environmental and Biological Resources	
Appendix G	Risk Analysis	
Appendix H	Beach Management Strategies	
Appendix I	Community Outreach	



METHODS

Analyze topographic and bathymetric data to determine beach evolution through evolution parameters

- ⊗ **Dune position and elevation**— movement and growth/erosion of the dune
- ⊕ **Shoreline position**— tracks the beach's seaward limits
- ↔ **Beach width and berm elevation**— provides insight on the beach's protective buffer and available recreation space
- 📦 **Volume**— quantify erosion or accretion patterns

Analyzed in the alongshore and across shore directions

SURVEYS ANALYZED

- 1 **May 1997 to Summer 2024**—long-term, 30-year period
- 2 **August 2004 to Summer 2024**—intermediate, 20-year period
August 2004 survey occurred prior to the 2004 hurricanes
- 3 **Summer 2014 to Summer 2024**—intermediate, 10-year period
Summer 2014 survey occurred prior to Hurricane Matthew (October 2016) and several other recent major hurricanes
- 4 **Summer 2019 to Summer 2024**—near-term changes over the last five years since the most recent BPP update (2019)
Beach changes in the wake of Hurricanes Ian and Nicole (September and November 2022)

BEACH TRENDS

DUNE POSITION CHANGE

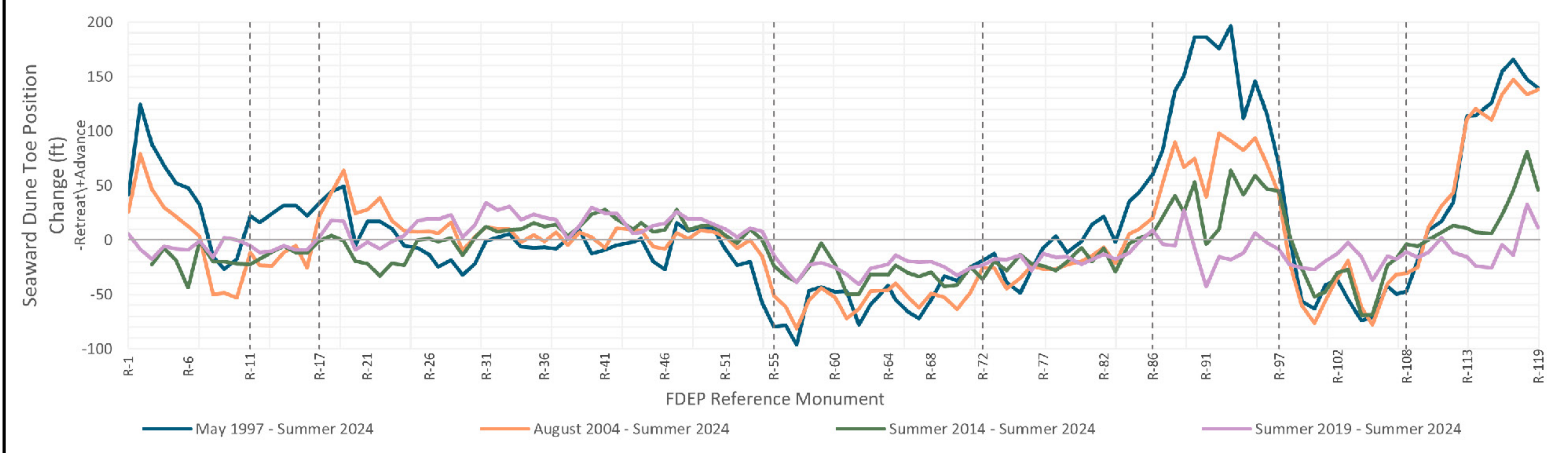
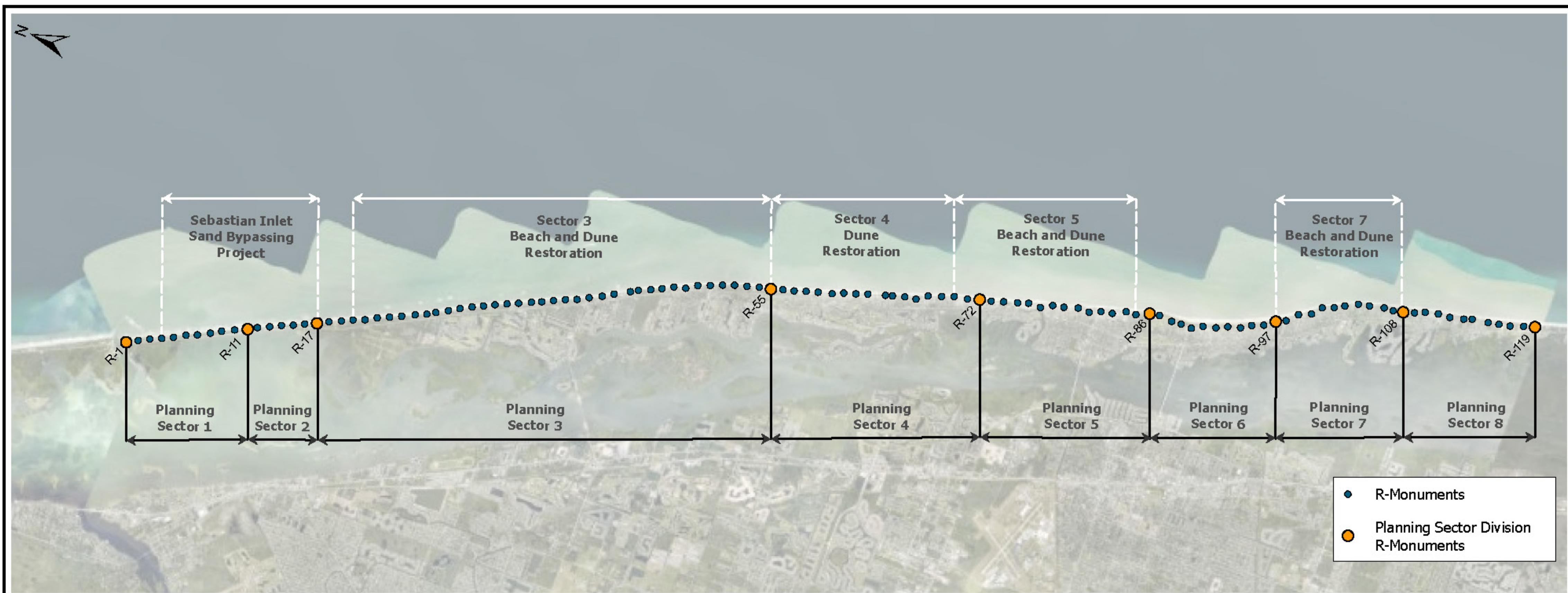

DUNE POSITION CHANGE-BY SECTOR

Sector	1997-2024	2004-2024	2014-2024	2019-2024
Planning Sector 1	+++ 38 ft	+/- 5 ft	- -20 ft	- -6 ft
Planning Sector 2	++ 26 ft	- -14 ft	- -12 ft	- -8 ft
Planning Sector 3	+/- -4 ft	+ 8 ft	+/- 4 ft	+ 14 ft
Planning Sector 4	--- -54 ft	--- -55 ft	-- -32 ft	-- -26 ft
Planning Sector 5	+/- -1 ft	- -18 ft	- -17 ft	- -15 ft
Planning Sector 6	+++ 142 ft	+++ 72 ft	++ 35 ft	- -8 ft
Planning Sector 7	--- -44 ft	--- -44 ft	-- -32 ft	- -19 ft
Planning Sector 8	+++ 87 ft	+++ 84 ft	++ 21 ft	- -7 ft

TAYLOR ENGINEERING INC.
 10199 SOUTHSIDE BLVD.
 SUITE 310
 JACKSONVILLE, FL 32256
 CERTIFICATE OF AUTHORIZATION # 4815

INDIAN RIVER COUNTY BEACH PRESERVATION PLAN
 FIGURE D.3 - COUNTYWIDE
 SEAWARD DUNE TOE POSITION CHANGE
 INDIAN RIVER COUNTY, FL

0 5,000 10,000 15,000 20,000 25,000
 Feet
 Imagery Source: ESRI

INDIAN RIVER CO.

PROJECT: C2024-047
 DRAWN BY: PL
 SHEET: 1 OF 1
 DATE: MAR 2026

BEACH TRENDS

SHORELINE POSITION CHANGE

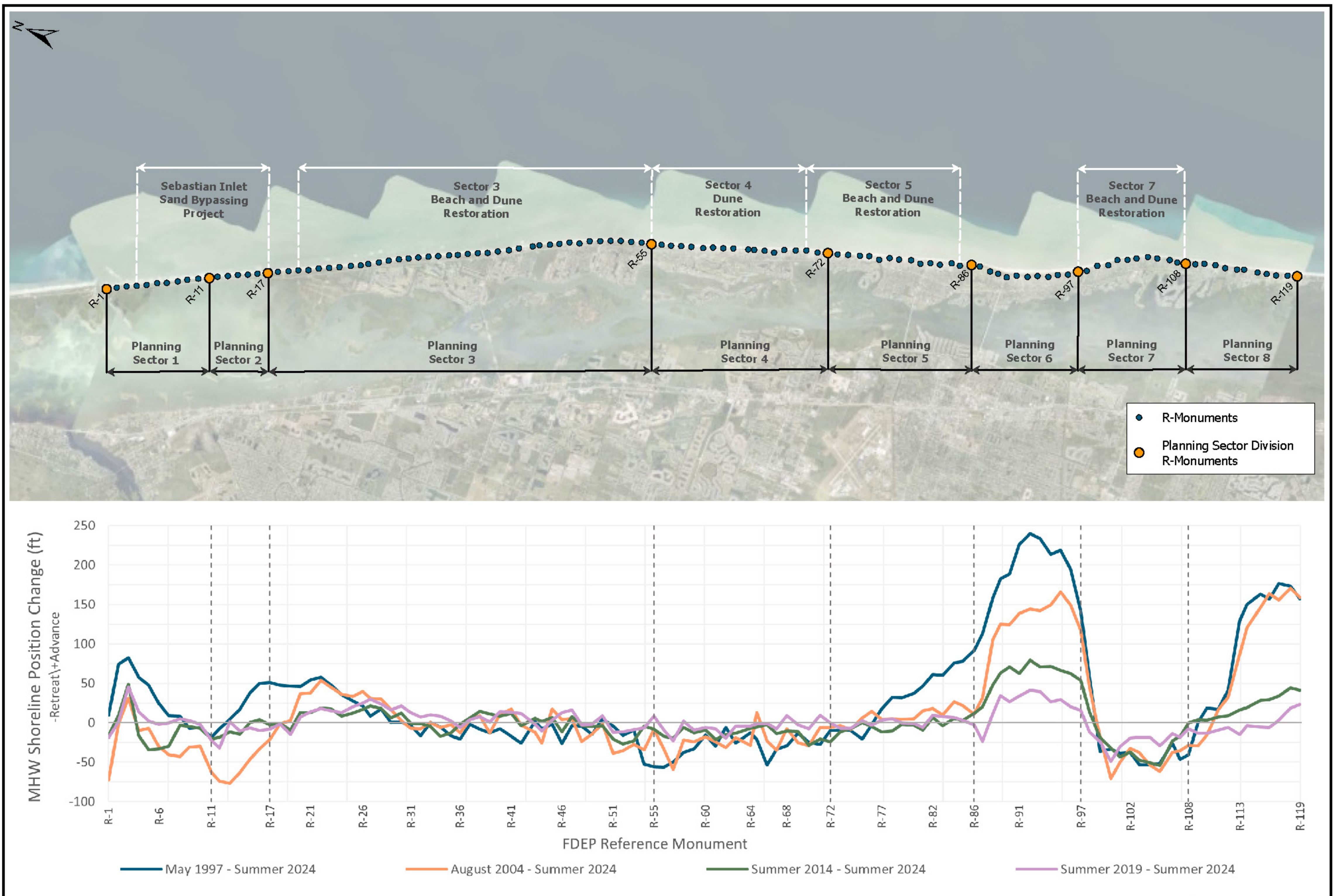

SHORELINE POSITION CHANGE-BY SECTOR

Sector	1997-2024	2004-2024	2014-2024	2019-2024
Planning Sector 1	++ 27 ft	-- -26 ft	- -10 ft	+/- 3 ft
Planning Sector 2	++ 21 ft	--- -56 ft	- -8 ft	- -12 ft
Planning Sector 3	+/- 4 ft	+/- 4 ft	+/- 2 ft	+ 7 ft
Planning Sector 4	-- -29 ft	-- -23 ft	- -14 ft	+/- -5 ft
Planning Sector 5	++ 31 ft	+ 8 ft	+/- -4 ft	+/- 1 ft
Planning Sector 6	+++ 192 ft	+++ 124 ft	+++ 60 ft	++ 23 ft
Planning Sector 7	-- -26 ft	-- -29 ft	-- -27 ft	-- -21 ft
Planning Sector 8	+++ 102 ft	+++ 89 ft	++ 21 ft	+/- -2 ft

TAYLOR ENGINEERING INC.
 10199 SOUTHSIDE BLVD.
 SUITE 310
 JACKSONVILLE, FL 32256
 CERTIFICATE OF AUTHORIZATION # 4815

INDIAN RIVER COUNTY BEACH PRESERVATION PLAN
 FIGURE D.4 - COUNTYWIDE
 MHW SHORELINE POSITION CHANGE
 INDIAN RIVER COUNTY, FL

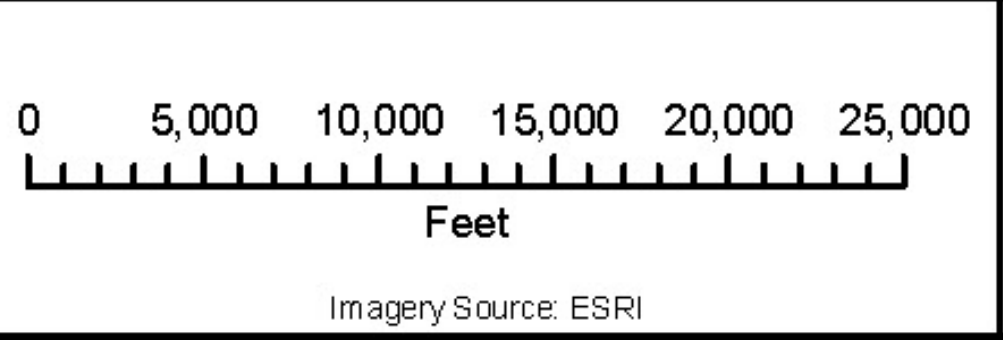

PROJECT: C2024-047
 DRAWN BY: PL
 SHEET: 1 OF 1
 DATE: MAR 2026

BEACH TRENDS

BEACH WIDTH CHANGE

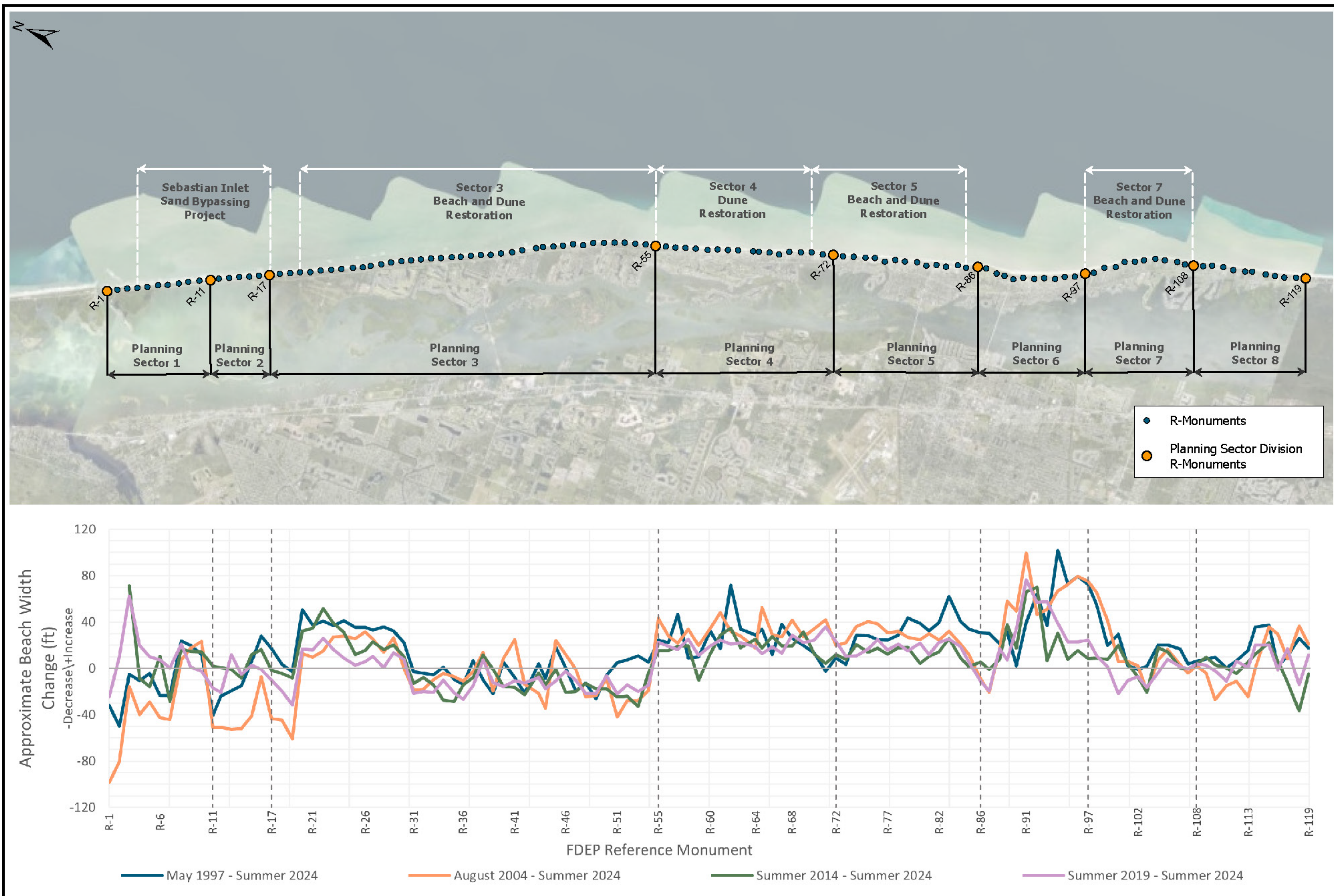

BEACH WIDTH CHANGE- BY SECTOR

Sector	1997-2024	2004-2024	2014-2024	2019-2024
Planning Sector 1	- -11 ft	-- -31 ft	++ 21 ft	+ 9 ft
Planning Sector 2	+/- -5 ft	--- -42 ft	+/- 4 ft	+/- -3 ft
Planning Sector 3	+ 8 ft	+/- -4 ft	+/- -2 ft	- -7 ft
Planning Sector 4	++ 25 ft	++ 32 ft	+ 18 ft	++ 21 ft
Planning Sector 5	++ 32 ft	++ 26 ft	+ 13 ft	+ 16 ft
Planning Sector 6	+++ 49 ft	+++ 52 ft	++ 25 ft	++ 31 ft
Planning Sector 7	+ 19 ft	+ 15 ft	+/- 5 ft	+/- -3 ft
Planning Sector 8	+ 15 ft	+/- 5 ft	+/- 0 ft	+/- 5 ft

TAYLOR ENGINEERING INC.
 10199 SOUTHSIDE BLVD.
 SUITE 310
 JACKSONVILLE, FL 32256
 CERTIFICATE OF AUTHORIZATION # 4815

INDIAN RIVER COUNTY BEACH PRESERVATION PLAN
 FIGURE D.5 - COUNTYWIDE APPROXIMATE BEACH WIDTH CHANGE
 INDIAN RIVER COUNTY, FL

0 5,000 10,000 15,000 20,000 25,000
 Feet
 Imagery Source: ESRI



PROJECT: C2024-047
 DRAWN BY: PL
 SHEET: 1 OF 1
 DATE: MAR 2026

BEACH TRENDS

VOLUME CHANGE ABOVE MHW

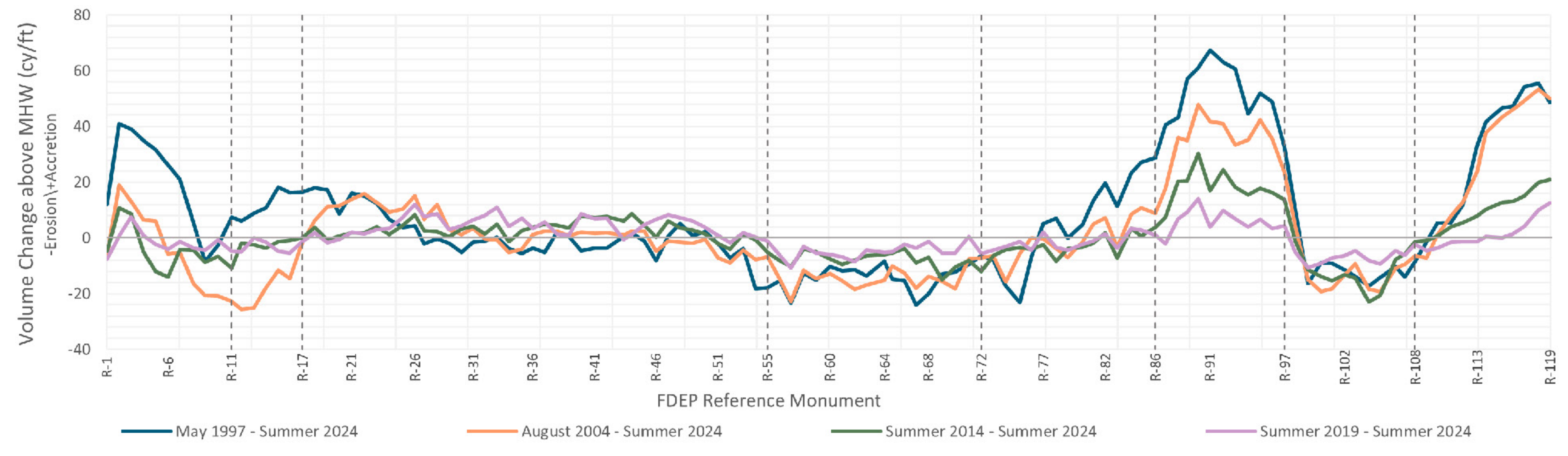
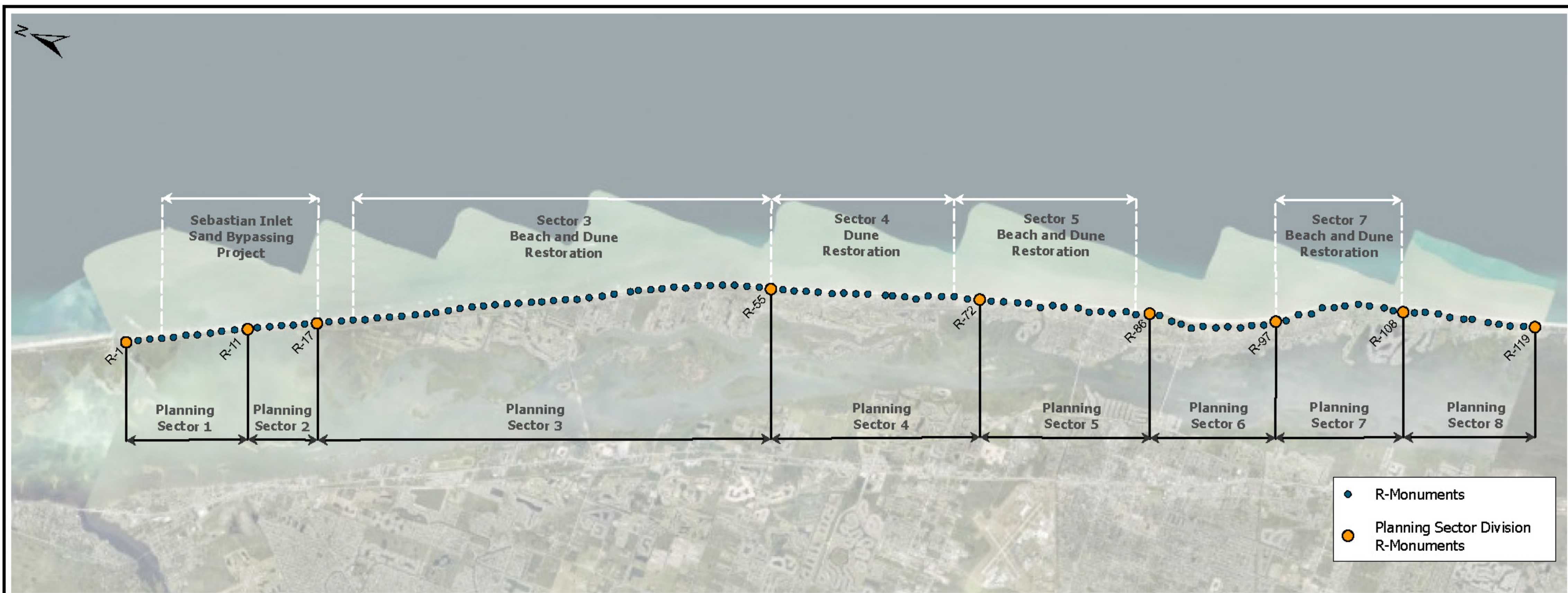

VOLUME CHANGE ABOVE MHW- BY SECTOR

Sector	1997-2024	2004-2024	2014-2024	2019-2024
Planning Sector 1	+ 19 cy/ft	+/- -4 cy/ft	+/- -5 cy/ft	+/- -2 cy/ft
Planning Sector 2	+ 12 cy/ft	- -18 cy/ft	+/- -3 cy/ft	+/- -3 cy/ft
Planning Sector 3	+/- 1 cy/ft	+/- 3 cy/ft	+/- 3 cy/ft	+/- 4 cy/ft
Planning Sector 4	- -14 cy/ft	- -15 cy/ft	- -8 cy/ft	+/- -5 cy/ft
Planning Sector 5	+/- 5 cy/ft	+/- -1 cy/ft	+/- -3 cy/ft	+/- -2 cy/ft
Planning Sector 6	+++ 52 cy/ft	++ 35 cy/ft	+ 18 cy/ft	+ 6 cy/ft
Planning Sector 7	- -9 cy/ft	- -11 cy/ft	- -11 cy/ft	- -7 cy/ft
Planning Sector 8	++ 31 cy/ft	++ 28 cy/ft	+ 10 cy/ft	+/- 2 cy/ft

*cy/ft- cubic yards per foot

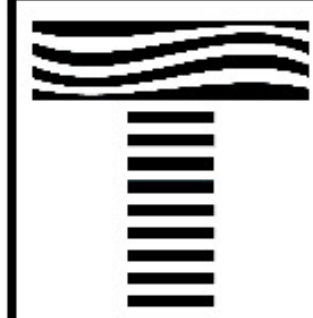
 **TAYLOR ENGINEERING INC.**
 10199 SOUTHSIDE BLVD.
 SUITE 310
 JACKSONVILLE, FL 32256
CERTIFICATE OF AUTHORIZATION # 4815

INDIAN RIVER COUNTY BEACH PRESERVATION PLAN
FIGURE D.6 - COUNTYWIDE VOLUME CHANGE ABOVE MEAN HIGH WATER INDIAN RIVER COUNTY, FL

0 5,000 10,000 15,000 20,000 25,000
 Feet
Imagery Source: ESRI

 INDIAN RIVER CO.

PROJECT: C2024-047
 DRAWN BY: PL
 SHEET: 1 OF 1
 DATE: MAR 2026

BEACH TRENDS

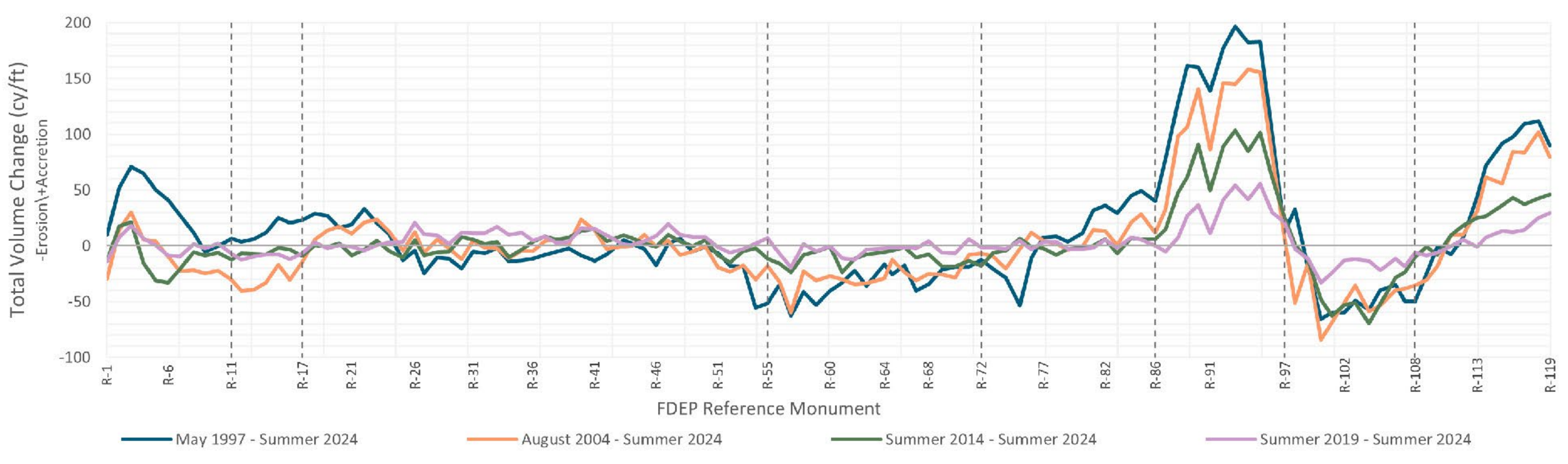
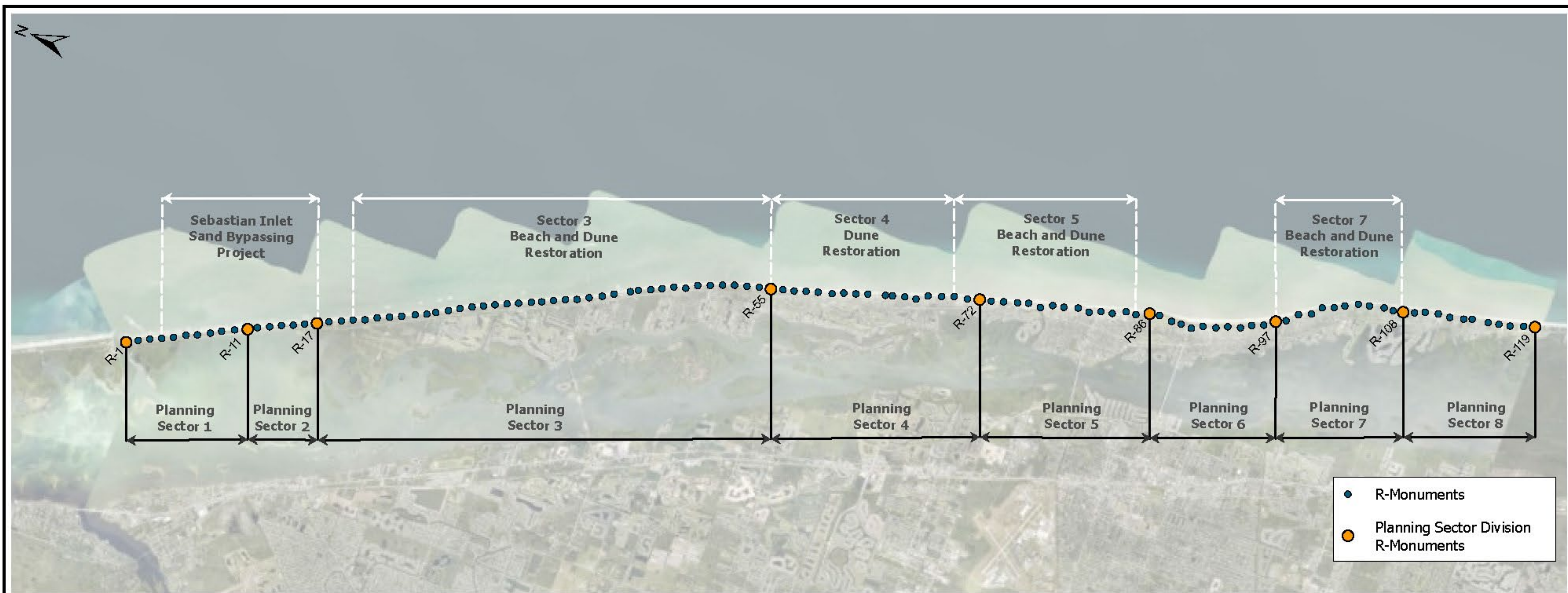

VOLUME CHANGE LANDWARD OF HARDBOTTOM EDGE



VOLUME CHANGE LANDWARD OF HARDBOTTOM EDGE- BY SECTOR

Sector	1997-2024	2004-2024	2014-2024	2019-2024
Planning Sector 1	++ 30 cy/ft	- -9 cy/ft	- -10 cy/ft	+/- 0 cy/ft
Planning Sector 2	+ 14 cy/ft	-- -31 cy/ft	- -6 cy/ft	- -10 cy/ft
Planning Sector 3	+/- -4 cy/ft	+/- 1 cy/ft	+/- 1 cy/ft	+ 6 cy/ft
Planning Sector 4	-- -32 cy/ft	-- -28 cy/ft	- -11 cy/ft	+/- -4 cy/ft
Planning Sector 5	+ 8 cy/ft	+/- 4 cy/ft	+/- -1 cy/ft	+/- 1 cy/ft
Planning Sector 6	+++ 140 cy/ft	+++ 107 cy/ft	+++ 66 cy/ft	++ 29 cy/ft
Planning Sector 7	--- -38 cy/ft	--- -47 cy/ft	--- -37 cy/ft	- -14 cy/ft
Planning Sector 8	+++ 51 cy/ft	+++ 41 cy/ft	++ 24 cy/ft	+ 8 cy/ft

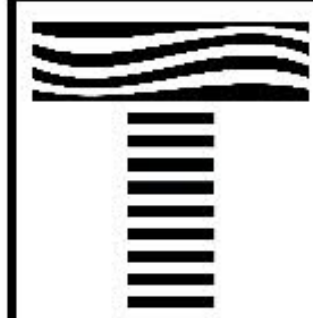
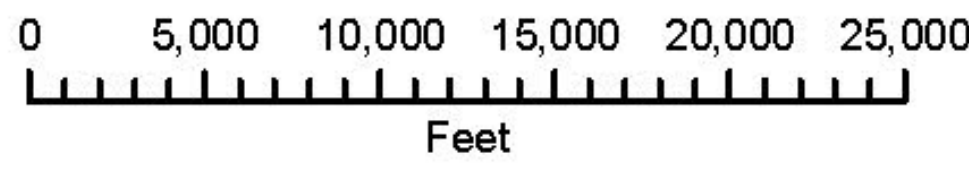
*cy/ft- cubic yards per foot

 TAYLOR ENGINEERING INC. 10199 SOUTHSIDE BLVD. SUITE 310 JACKSONVILLE, FL 32256 <small>CERTIFICATE OF AUTHORIZATION # 4815</small>	INDIAN RIVER COUNTY BEACH PRESERVATION PLAN FIGURE D.8- COUNTYWIDE TOTAL VOLUME CHANGE INDIAN RIVER COUNTY, FL	 <small>Imagery Source: ESRI</small>		PROJECT: C2024-047 DRAWN BY: PL SHEET: 1 OF 1 DATE: MAR 2026
	<p style="text-align: center;">INDIAN RIVER CO.</p>			

STORM AND NOURISHMENT HISTORY SINCE 2019

2022



2024



*cy- cubic yards

PLANNING SECTORS 1 & 2 NOURISHMENTS SINCE 2019		
Year	Volume	Placement Area
2019-	113,570 cy	R-10 to R-17
2021-	60,200 cy	R-9 to R-17
2023-	30,019 cy	R-10 to R-17
2024/2025-	135,196 cy	R-8 to R-17
2025/2026-	in progress	R-3.5 to R-11

data provided by the Sebastian Inlet District

PLANNING SECTOR 3 NOURISHMENTS SINCE 2019		
Year	Volume	Placement Area
2021-	348,953 cy	R-20 to R-40
2022-	180,139 cy	R-40 to R-55
2023-	6,560 cy	Emergency Repairs
2024-	223,040 cy	R-20 to R-55

PLANNING SECTOR 4 NOURISHMENTS SINCE 2019		
Year	Volume	Placement Area
2025-	116,970 cy	R-55 to R-70

PLANNING SECTOR 5 NOURISHMENTS SINCE 2019		
Year	Volume	Placement Area
2020-	171,149 cy	R-70 to R-86
2021-	Dune Plants	R-70 to R-86
2023-	9,856 cy	Emergency Repairs
2026-	in progress	R-70 to R-86

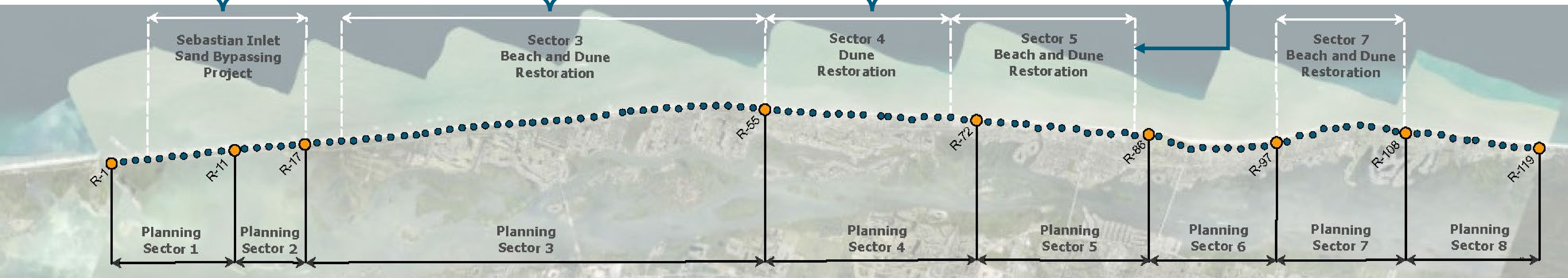

WATER LEVELS AND SEA LEVEL RISE PROJECTIONS

Ocean water levels are constantly shifting and understanding how they behave is critical for effective coastal management. Coastal water levels describe the ocean’s height at any given time, driven by tides, winds, atmospheric pressure, offshore waves, and long-term sea level trends (Dangendorf et al., 2023). These changing water levels actively shape Indian River County’s shoreline, influencing daily beach conditions, long-term erosion, and flooding risks.

WATER LEVEL RECURRENCE INTERVALS

- The **range of water elevations** likely to occur under **specific storm conditions** and the associated likelihood of occurrence
- Calculated from tide gauge records or modeling a large number of synthetic storm events
 - NOT tied to particular historical events**
- This BPP uses **USACE SACS 1% AEP** water levels for the risk assessment

**The South Atlantic Coastal Study (SACS) is a regional-scale coastal hazard risk study that USACE completed in 2022. The SACS calculated water level recurrence intervals inclusive of storm surge, tides, and wave-induced water level changes.*

The **one-percent annual exceedance probability (1% AEP)** means a given water level has a **one-percent chance (or 1-in-100 chance)** of being exceeded in any given year.

Sector	USACE SACS 1% AEP Water Levels (ft-NAVD88)
Planning Sector 1	7.9
Planning Sector 2	8.0
Planning Sector 3	7.8
Planning Sector 4	8.3
Planning Sector 5	8.4
Planning Sector 6	8.0
Planning Sector 7	7.9
Planning Sector 8	8.0

TIDAL DATUM

- A **standardized reference level** used to describe typical ocean heights at a given location
- Represent **average conditions** over a 19-year period

**The current 19-year period over which mean tide observations are calculated is from 1983-2001. This is based on the current National Tidal Datum Epoch set by NOAA.*

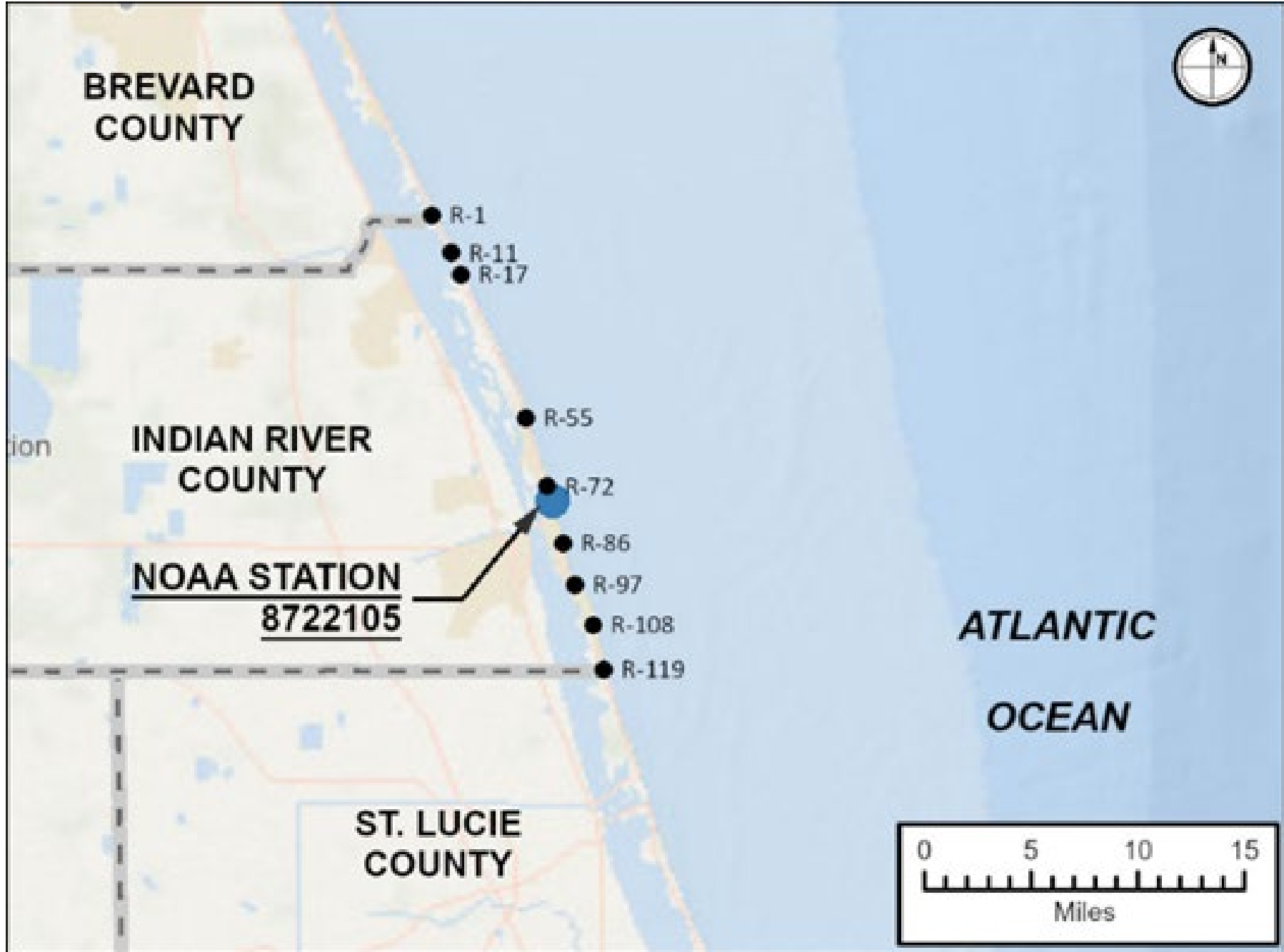

This BPP uses **+0.6 ft-NAVD88** to define MHW and shoreline position.

SEA LEVEL RISE PROJECTIONS

- Describe **long-term increases** in the ocean’s average height
- Based on over 150 years of water level measurements
- Directly influences **coastal flooding, erosion,** and the stability of beaches and dunes
- This plan update estimates future local sea level rise for multiple planning horizons using both **NOAA 2022** and the **USACE 2013** projections

**Florida Statute requires the use of NOAA 2022 Intermediate Low and Intermediate for Vulnerability Assessments*

***USACE requires the use of USACE curves for federally sponsored projects*

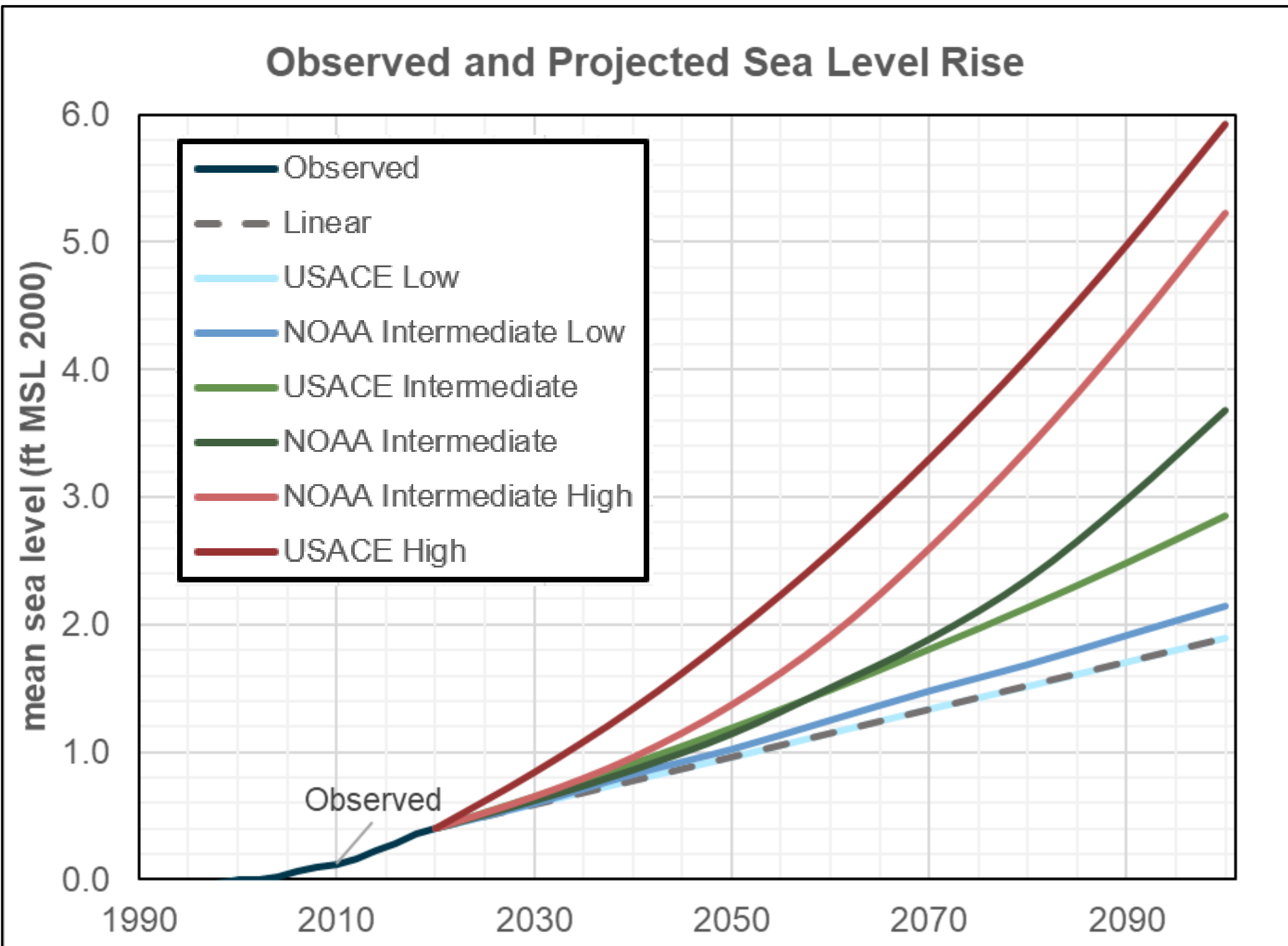

Between **1992 and 2020**, water level stations along Florida’s east coast show that sea level has **increased by approximately 6 inches.**

By 2050, projections show that sea levels could **increase an additional 8 to 10 inches** based on NOAA 2022 intermediate and USACE 2013 intermediate projections.

DATA SOURCES

- NOAA Tidal Benchmark Station 8722105
- USACE South Atlantic Coastal Study (SACS) 1% annual exceedance probability (AEP) stillwater elevations (SWEL)
- NOAA 2022 Intermediate Low, Intermediate, and Intermediate High sea level rise projections
- USACE 2013 Low, Intermediate, and High sea level rise projections

VULNERABILITY PARAMETERS

PRIMARY

SHORELINE ENCROACHMENT 1

- the horizontal distance (or “buffer”) between the MHW shoreline position and infrastructure

INFRASTRUCTURE EXPOSURE 2

- the percentage of parcels where infrastructure is within or below 1 ft of the USACE SACS 1% AEP SWEL

SECONDARY

ARMORING EXPOSURE 3

- the percentage of parcels where seawalls are within or below 1 ft of the USACE SACS 1% AEP SWEL

HISTORICAL EROSION RATE

- the average shoreline change rate since 2019 calculated via linear regression

SBEACH* STORM RESPONSE

- the horizontal buffer between infrastructure and the landward-most 1 ft of vertical erosion associated with a 4% AEP storm event, regularly referred to as the 25-year event

**USACE’s Storm-induced BEAch CHange (SBEACH) model calculates transect-based cross-shore sediment transport*

OTHER DECISION-MAKING FACTORS

ADDITIONAL COMMUNITY INFORMATION

- Average infrastructure elevation
- Armoring coverage
- Land uses
- Public beach accesses
- Critical assets

**See “Additional Community Information” Poster for more information*

DATA SOURCES

- Indian River County parcel data
- FDEP R-monument locations
- Coastal shoreline armoring data
- 2024 pre-event aerials (NOAA)
- 2024 aerials (FDOT)
- 2024 post-Hurricane Milton aerials (USACE/FEMA)
- 2024 post-Hurricane Milton LiDAR (NOAA)
- USACE South Atlantic Coastal Study (SACS) 1% annual exceedance probability (AEP) stillwater elevations (SWEL)

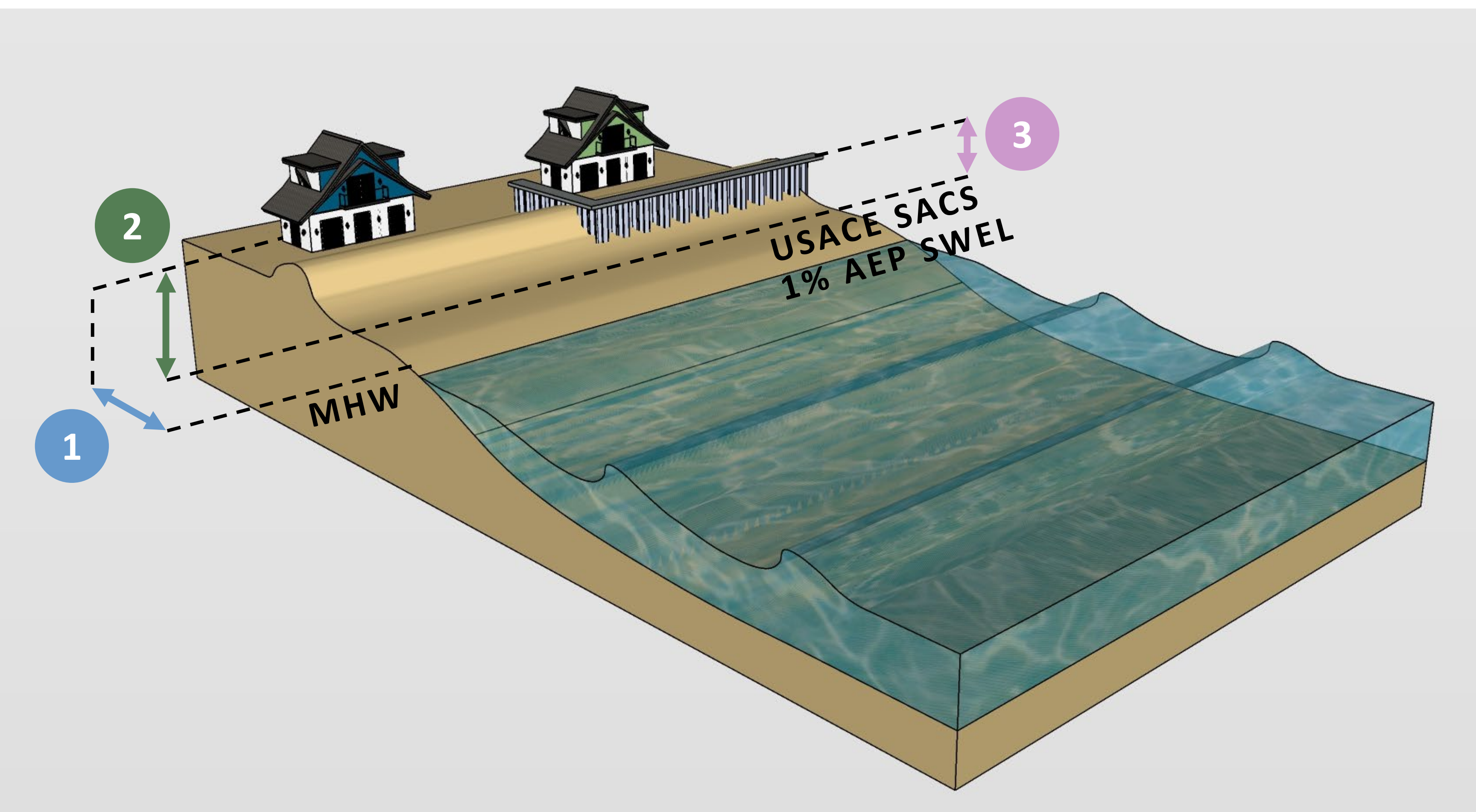

GEOSPATIAL ANALYSIS

1. Mark the approximate seaward edge of upland infrastructure within each parcel

- Infrastructure categories:
- Home
 - Road
 - Condominium
 - Hotel
 - Commercial- including restaurants, shops, or office spaces
 - Park with amenities

2. Calculate the **elevation** at each infrastructure point and the **distance** between infrastructure points and the MHW shoreline position contour

3. Use the location and elevation data to classify and inform vulnerability parameters

RISK ASSESSMENT RESULTS

RISK RESULTS- BY SECTOR

Sector	Shoreline Encroachment- feet	Infrastructure Exposure- number of parcels (%)	Armoring Exposure- number of parcels (%)	Historical Shoreline Change Rate- feet/year	SBEACH Storm Response- feet
Planning Sector 1 – R-1 to R-11	323	15 (94%)	-	0.2	207
Planning Sector 2 – R-11 to R-17	173	56 (67%)	-	-3.1	69
Planning Sector 3 – R-17 to R-55	179	3 (1%)	0 (0%)	2.6	67
Planning Sector 4 – R-55 to R-72	175	1 (1%)	-	-1.3	49
Planning Sector 5 – R-72 to R-86	153	1 (1%)	1 (1%)	-1.0	35
Planning Sector 6 – R-86 to R-97	498	0 (0%)	-	4.2	351
Planning Sector 7 – R-97 to R-108	178	2 (2%)	10 (12%)	-1.6	40
Planning Sector 8 – R-108 to R-119	350	0 (0%)	-	1.2	206
Average	233	-	-	0.8	110
Standard Deviation	127	-	-	3.2	119

Sector	Shoreline Encroachment	Infrastructure Exposure	Armoring Exposure	Historical Shoreline Change Rate	SBEACH Storm Response	Risk Score	Rank
Planning Sector 1 – R-1 to R-11	Low (1)	High (3)	Low (1)	Low (1)	Low (1)	26	6
Planning Sector 2 – R-11 to R-17	Medium (2)	High (3)	Low (1)	High (3)	Medium (2)	37	3
Planning Sector 3 – R-17 to R-55	Medium (2)	Medium (2)	Low (1)	Low (1)	Medium (2)	28	5
Planning Sector 4 – R-55 to R-72	Medium (2)	Medium (2)	Low (1)	High (3)	High (3)	34	4
Planning Sector 5 – R-72 to R-86	High (3)	Medium (2)	Medium (2)	High (3)	High (3)	41	1
Planning Sector 6 – R-86 to R-97	Low (1)	Low (1)	Low (1)	Low (1)	Low (1)	16	7
Planning Sector 7 – R-97 to R-108	Medium (2)	Medium (2)	High (3)	High (3)	High (3)	38	2
Planning Sector 8 – R-108 to R-119	Low (1)	Low (1)	Low (1)	Low (1)	Low (1)	16	7
Weight	5	5	2	2	2	-	-

PRIMARY PRIMARY SECONDARY SECONDARY SECONDARY

RISK RESULTS- RANKING

- 1 Planning Sector 5
- 2 Planning Sector 7
- 3 Planning Sector 2
- 4 Planning Sector 4
- 5 Planning Sector 3
- 6 Planning Sector 1
- 7 Planning Sector 6
- 7 Planning Sector 8

TABLE LEGEND

POINTS

High (3)
Medium (2)
Low (1)

× weight = total score

↑ points = ↑ risk

OTHER DECISION-MAKING FACTORS

AVERAGE INFRASTRUCTURE ELEVATION

- the average elevation of shorefront infrastructure; note, this excludes large empty lots where infrastructure is set back

ARMORING COVERAGE

- the percentage of parcels with seawalls

LAND USES

- the percentage of beachfront shoreline classified as residential, commercial, and public land.
 - Residential- single-family and multi-family residential lands
 - Commercial- general, limited, neighborhood, and tourist oriented commercial lands
 - Public- public, conservation, federal-owned, state-owned, county-owned, and municipal-owned lands

PUBLIC BEACH ACCESSES

- the number of public beach accesses, as defined by Florida Administrative Code (FAC) 62B-36.002

CRITICAL ASSETS

- the number of beachfront critical assets, as defined by Florida Statute 380.093





DATA SOURCES

- Indian River County parcel, land zoning, and public access databases
- 2024 post-Hurricane Milton LiDAR (NOAA)
- Coastal shoreline armoring data
- Florida Statewide Vulnerability Assessment critical asset database

Sector	Parcel Count (Miles)	Average Infrastructure Elevation	Armoring Coverage	Land Uses (Residential/Commercial/Public)	Public Beach Accesses	Critical Assets
Planning Sector 1 – R-1 to R-11	16 (2 miles)	5.3	0 (0%)	0%/0%/100%	3 (1.5 per mile)	2
Planning Sector 2 – R-11 to R-17	84 (1.1 miles)	7.1	0 (0%)	93%/0%/7%	1 (0.9 per mile)	1
Planning Sector 3 – R-17 to R-55	223 (7.1 miles)	15.2	30 (13%)	70%/4%/27%	5 (0.7 per mile)	0
Planning Sector 4 – R-55 to R-72	103 (3.3 miles)	16.0	0 (0%)	100%/0%/0%	1 (0.3 per mile)	0
Planning Sector 5 – R-72 to R-86	90 (2.7 miles)	14.7	32 (36%)	28%/45%/27%	8 (3.0 per mile)	2
Planning Sector 6 – R-86 to R-97	70 (2.0 miles)	13.2	0 (0%)	74%/18%/8%	7 (3.6 per mile)	0
Planning Sector 7 – R-97 to R-108	83 (2.0 miles)	12.7	23 (28%)	100%/0%/0%	0 (0 per mile)	0
Planning Sector 8 – R-108 to R-119	69 (2.2 miles)	13.6	0 (0%)	93%/0%/7%	1 (0.5 per mile)	0

SHORELINE MANAGEMENT STRATEGIES

The BPP update focuses on the viability of different shoreline management strategies and their ability to reduce coastal risk, provide benefits such as recreation improvements or habitat enhancement, and their constructability along the Indian River County shoreline. To refine the management strategies and identify those best suited for the County, Taylor Engineering further investigated each strategy’s design, permitting requirements, maintenance needs, associated costs, potential project partners, benefits, drawbacks, and other notable considerations. Based on this evaluation, the project team identified the most viable shoreline management strategies for recommendation.

 Existing County Implemented Management Actions	 Discouraged County Management Actions
 Future County Management Considerations	 Homeowner Implemented Actions

NO ACTION

THE COMMUNITY AND DECISION-MAKERS DECIDE TO LET NATURE TAKE ITS COURSE

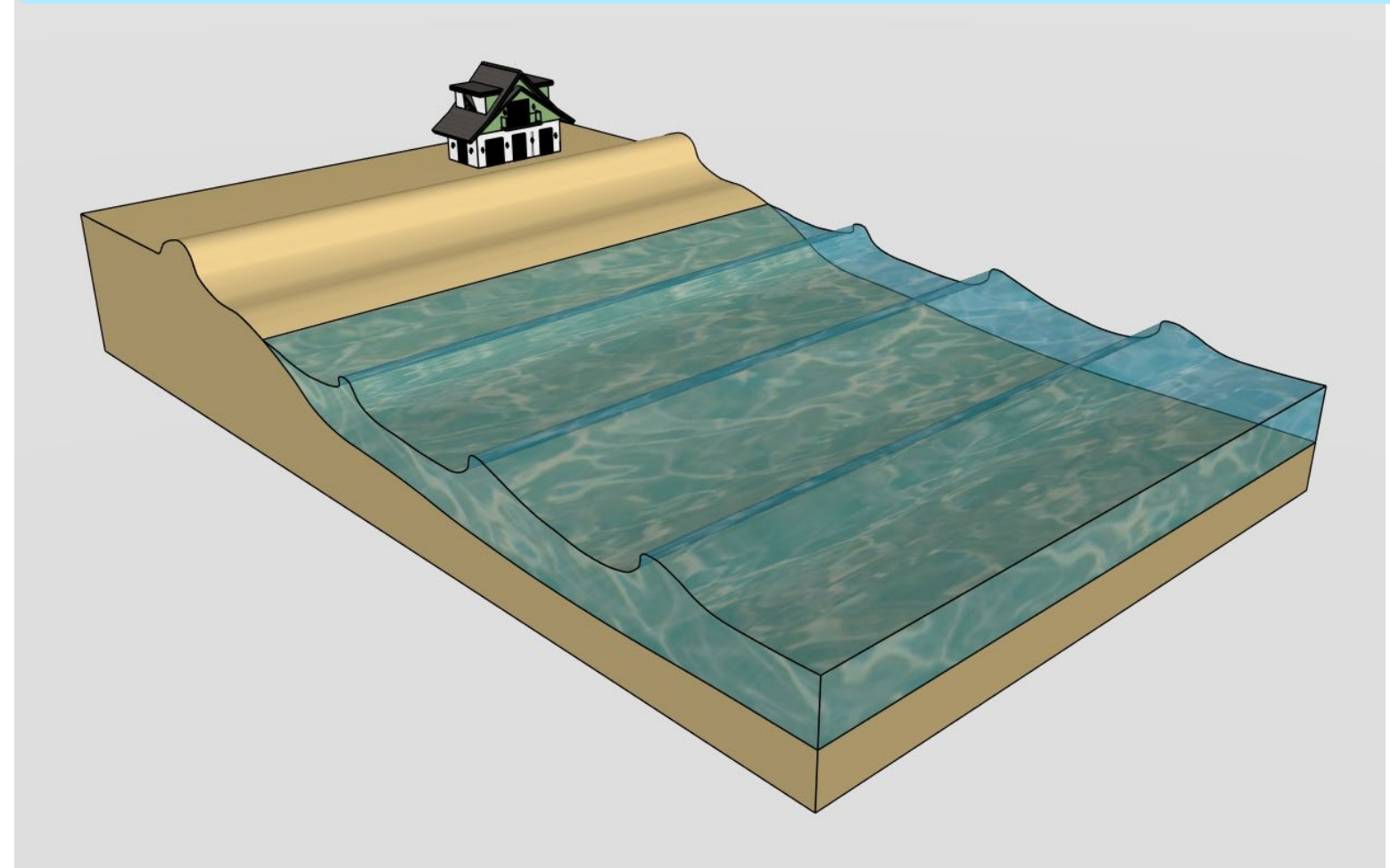

- Reflects a management approach in which communities and decision-makers allow natural processes to continue without intervention
- Evaluating this strategy requires decision-makers to consider the existing shoreline conditions within the planning sector and the level of risk they are willing to accept if those conditions continue
- Commonly serves as a baseline for comparing other shoreline management strategies
- In some cases (i.e., where accretional trends exist within a planning sector), active intervention may not be necessary

STRUCTURAL RELOCATION

RELOCATING STRUCTURES INLAND AND RESTORING THE BEACH SYSTEM TO ITS NATURAL STATE

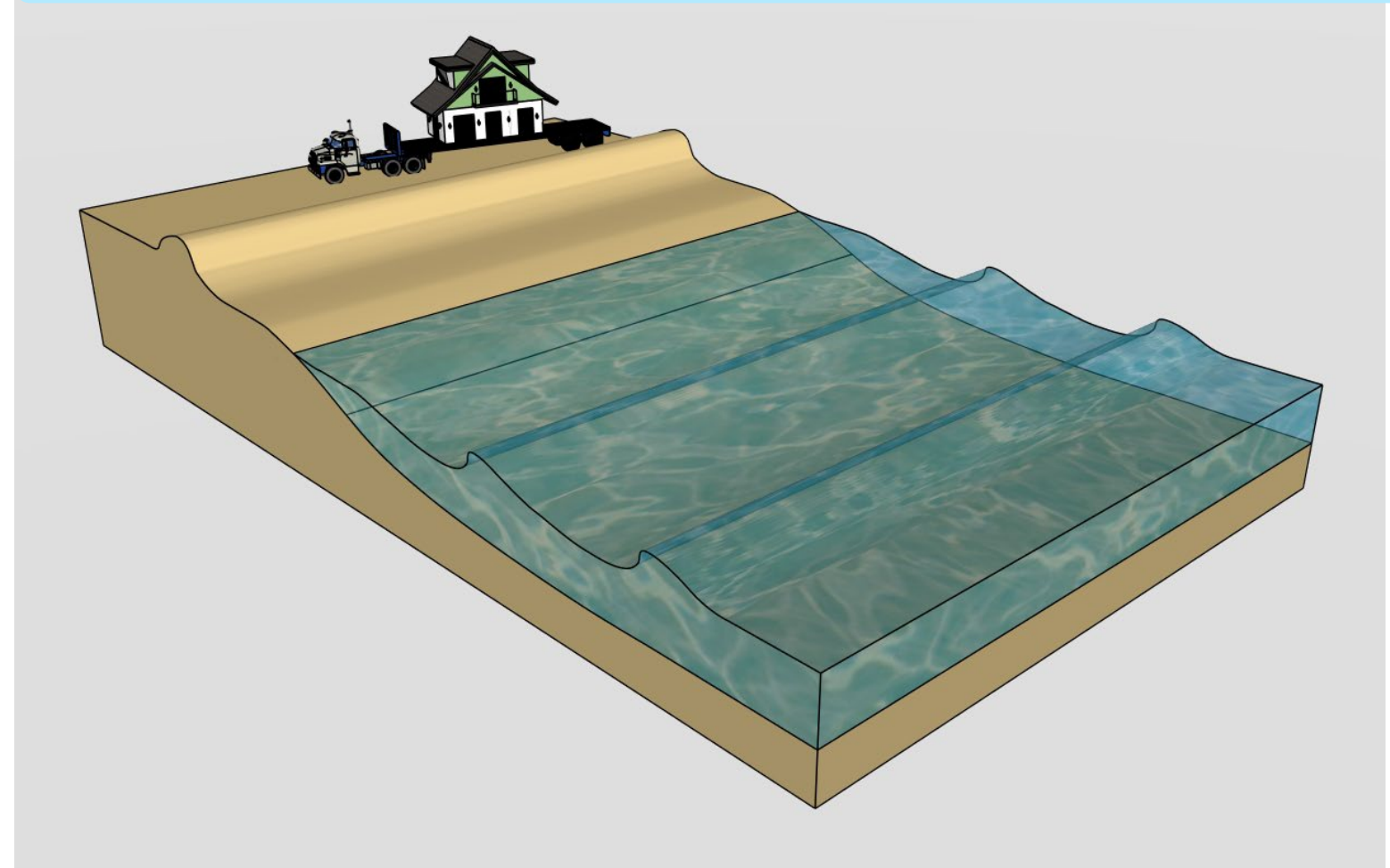

- Drastic but effective adaptation option
 - Greatly reduces the risks of storm damage and sea level rise for coastal infrastructure
- Governing agencies face major challenges when trying to implement relocation
 - Property ownership rights create legal and financial obstacles
 - Vacant land will then need to be maintained by an entity
- Requires acquisition of private property, coordination with residents and businesses, and construction of new infrastructure and services at the new development location
- Does not directly maintain or enhance the beach resource

SEAWALLS

A WALL INSTALLED AT THE LANDWARD EDGE OF THE BEACH PARALLEL TO SHORE TO PROTECT UPLAND INFRASTRUCTURE

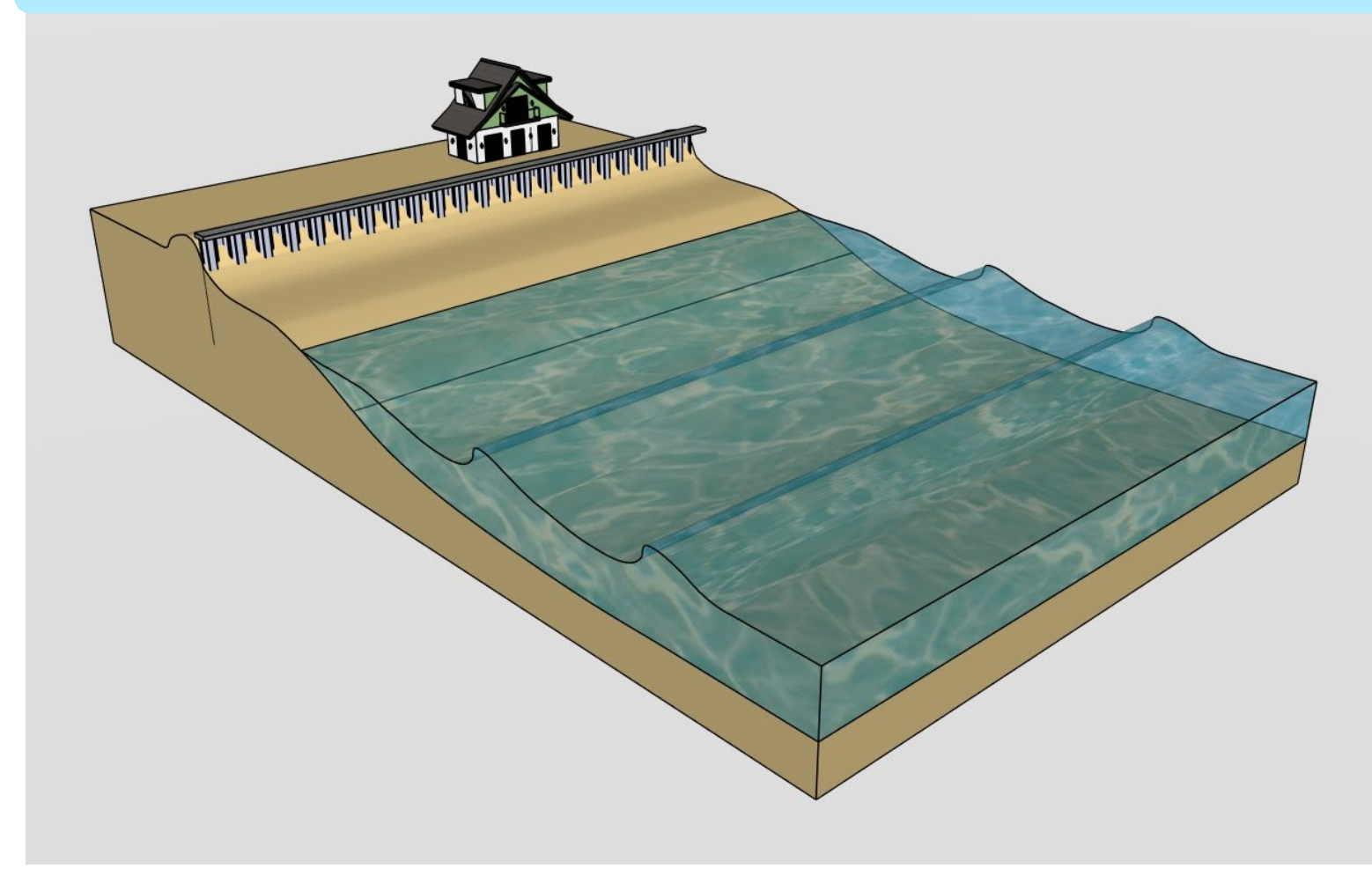

- Frequently installed by individual property owners
- Not generally recommended as a community-scale shoreline management strategy due to regulatory constraints and their well-documented coastal and ecological impacts
- Oftentimes accelerate erosion, narrow beaches, and, in some cases, contribute to the loss of adjacent land on neighboring, unarmored shorelines when exposed to water levels and waves
- Construction commonly results in dune habitat loss and disrupts the connection between the beach and upland
- Generally considered a last-resort option

REVTMENTS

A SERIES OF ROCK STRUCTURES, PLACED PARALLEL TO THE DUNE, TO DISSIPATE WAVE ENERGY

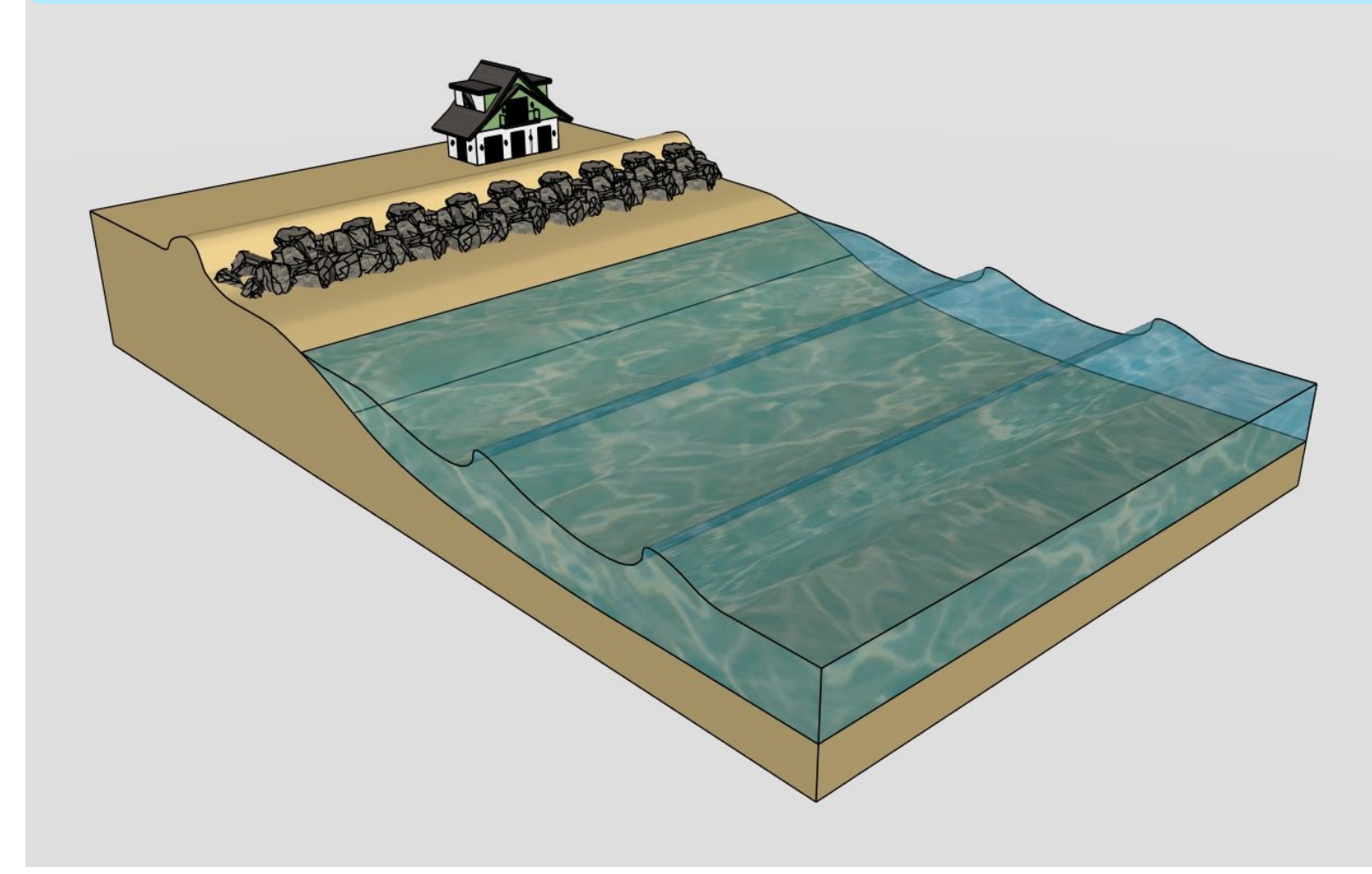

- Frequently installed by individual property owners
- May accelerate erosion and narrow beaches along adjacent shorelines when exposed to waves
- Construction commonly results in dune habitat loss and disrupts the connection between the beach and upland
- Typically have a large cross-shore footprint, further reducing beach width available for recreation, habitat, and nesting
- Provide limited storm damage protection
 - Do not prevent inundation
 - Storm water levels often exceed the structure’s height

GEOTUBES



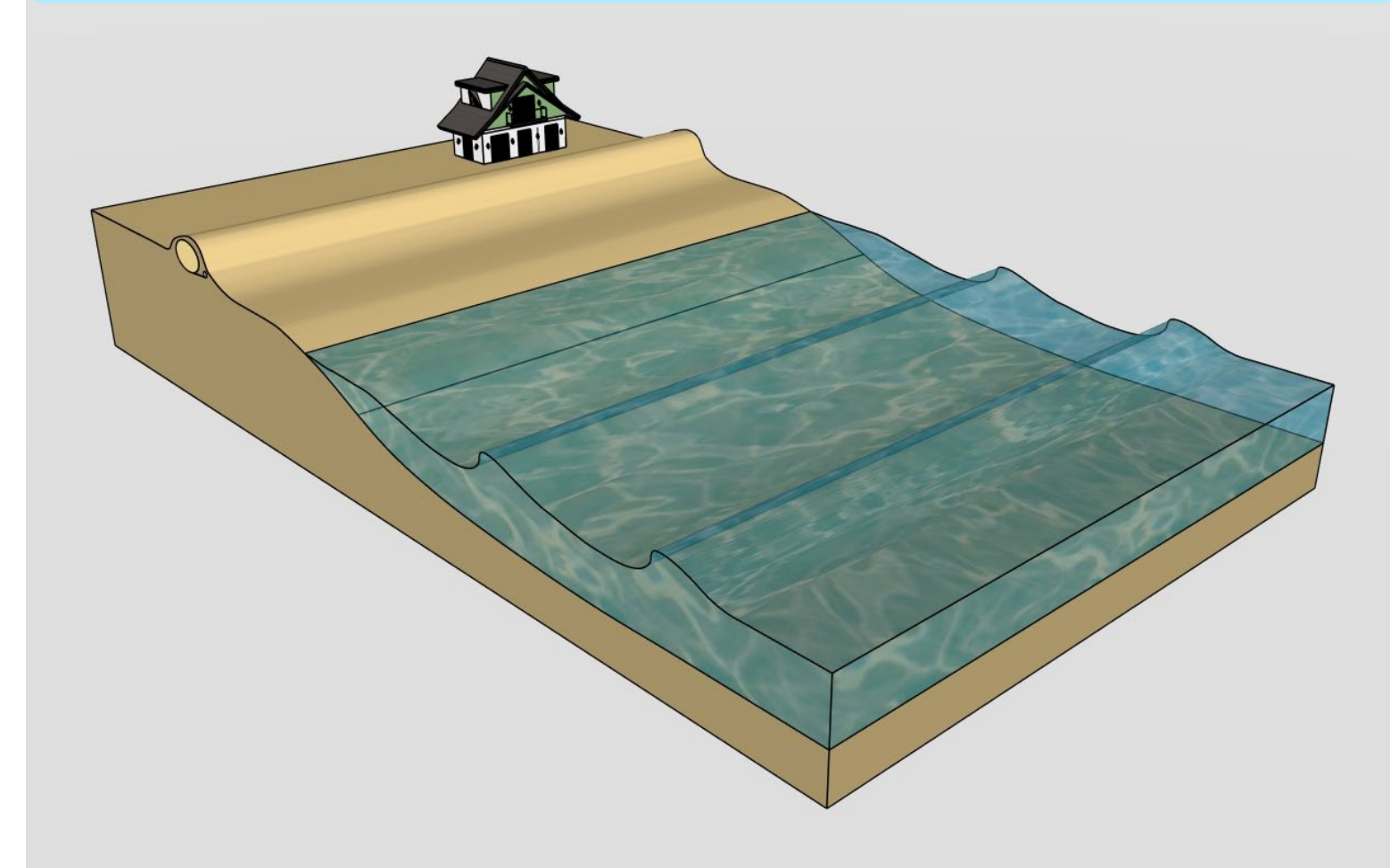

GEOTEXTILE TUBES FILLED WITH SAND AND USED AS THE CORE OF A ROCK STRUCTURE OR DUNE SYSTEM



- Installations occurred as an emergency response to storm events that left the beach in a severely eroded condition
- Typically require sand and vegetation to remain in place on top of the structure
 - Maintaining this cover is difficult
- Can significantly alter coastal processes and affect environmental resources once exposed
- Construction of a geotube-reinforced dune directly causes dune habitat loss

SHORELINE MANAGEMENT STRATEGIES

The BPP update focuses on the viability of different shoreline management strategies and their ability to reduce coastal risk, provide benefits such as recreation improvements or habitat enhancement, and their constructability along the Indian River County shoreline. To refine the management strategies and identify those best suited for the County, Taylor Engineering further investigated each strategy's design, permitting requirements, maintenance needs, associated costs, potential project partners, benefits, drawbacks, and other notable considerations. Based on this evaluation, the project team identified the most viable shoreline management strategies for recommendation.

 Existing County Implemented Management Actions	 Discouraged County Management Actions
 Future County Management Considerations	 Homeowner Implemented Actions

NEARSHORE SAND PLACEMENT

SAND PLACED IN THE NEARSHORE FOR WAVE ACTION TO MOVE IT ONSHORE AND RESTORE THE BEACH

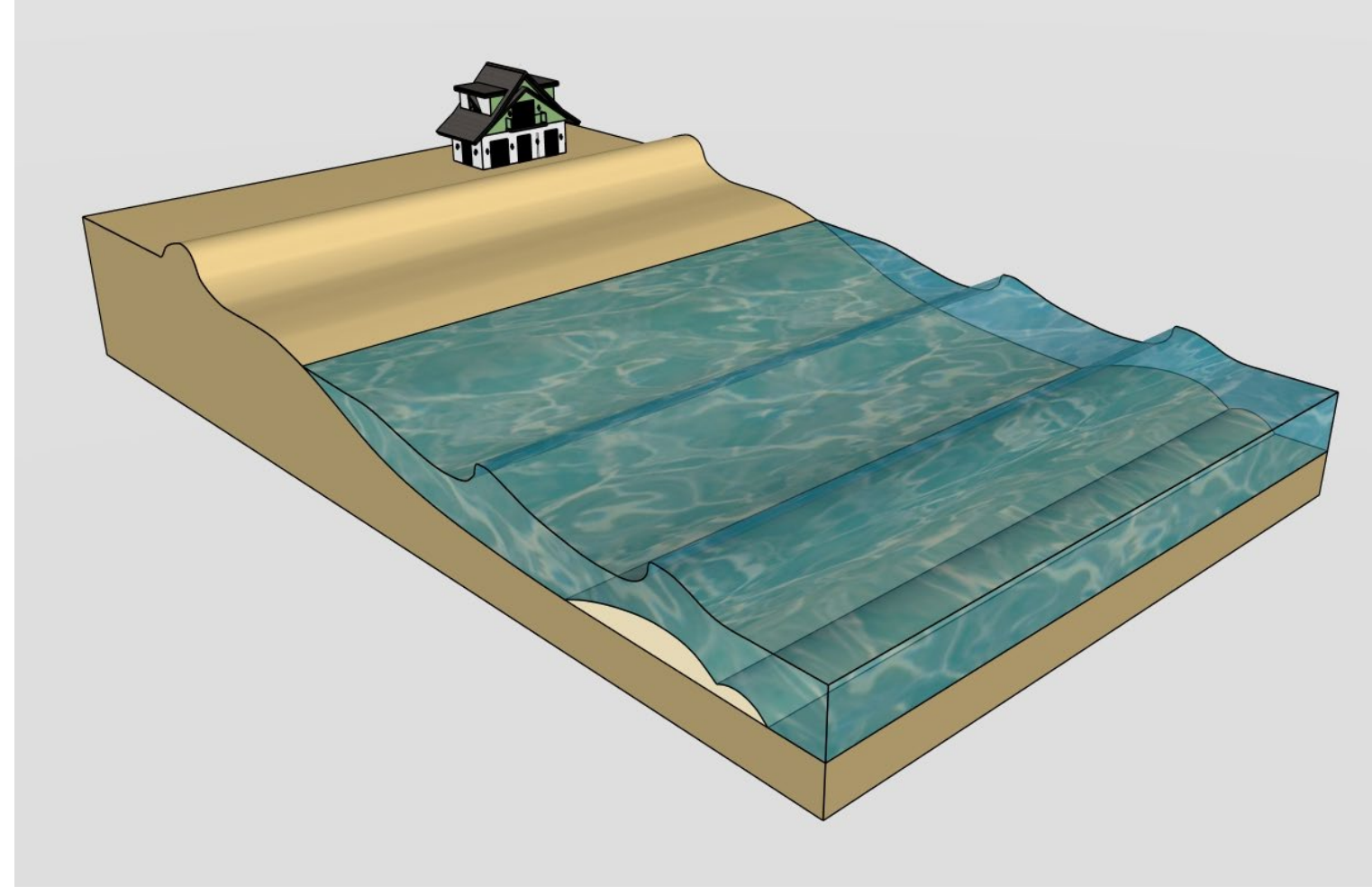

- Restores the coastal system by directly adding sand to it
- Does not immediately increase beach width or provide additional recreational space
- Effectiveness is condition dependent
- Sand is placed in the nearshore, where waves and currents gradually transport it in the nearshore system and toward the shoreline
- Most efficient when material can be sourced from a nearby navigation project (e.g., an inlet)
- Strategy impractical, or non-viable, in Indian River County due to impacts to extensive nearshore hardbottom
- Requires periodic renourishment

BEACH AND DUNE NOURISHMENT (non-impacting) (impacting)

PLACEMENT OF SAND ALONG THE BEACH DUNE, BERM, AND NEARSHORE AREAS TO EXTEND THE BEACH SEAWARD

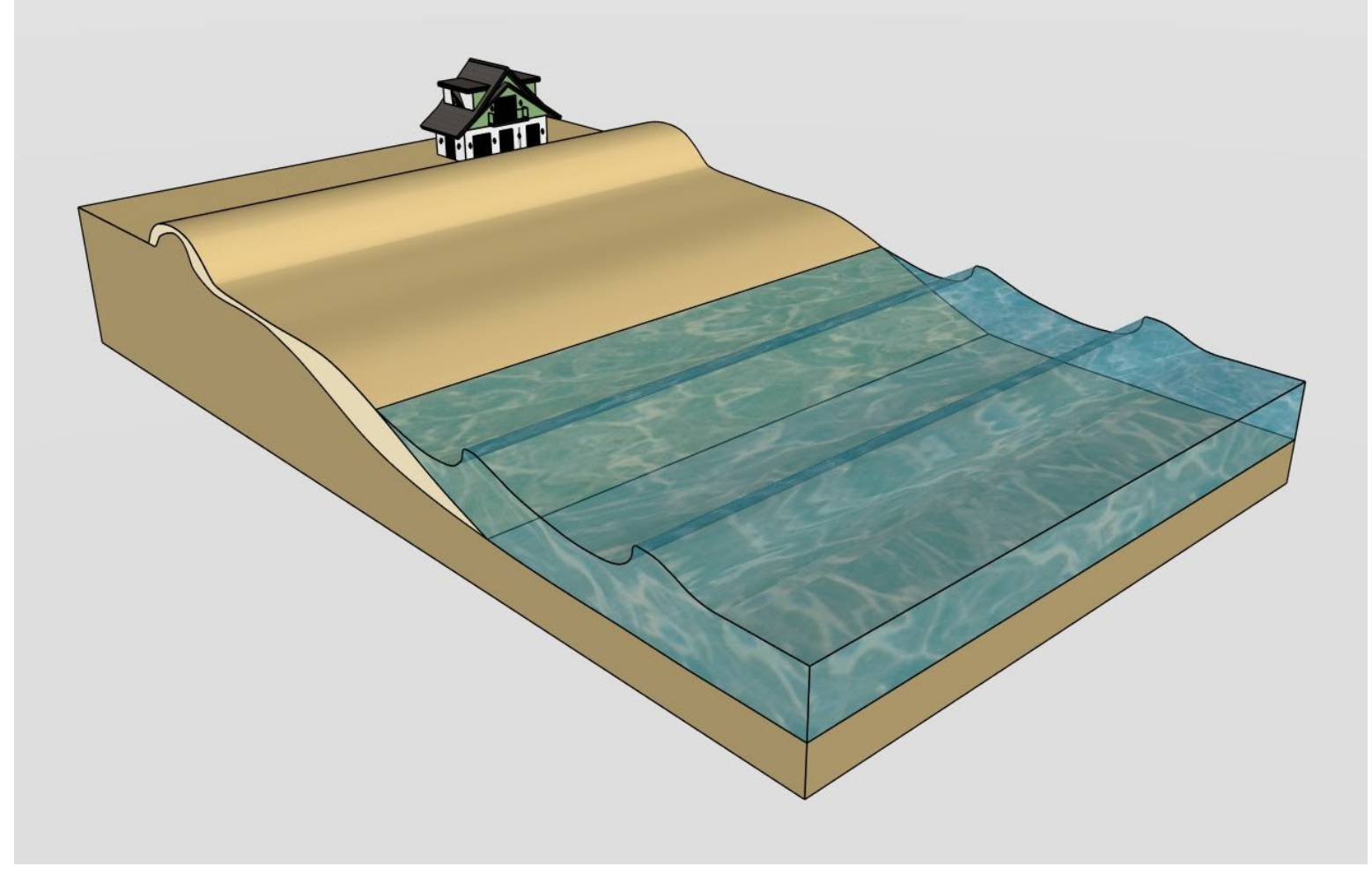

- Often-used shoreline management strategy
- Restores the coastal system by directly adding sand to it
- Often includes vegetative plantings and sand fencing within the design, which helps stabilize and reinforce the dune
- Expands beach width and increases recreational space
- Creates an additional buffer between coastal infrastructure and the ocean that helps protect property during storms
- Supports beach tourism and the local economy while also improving the beach habitat
- Risks\uncertainties associated with how quickly it will erode
- Adaptable for future conditions or evolving projects goals
- Requires periodic renourishment

BREAKWATERS

A SERIES OF NEARSHORE ROCK STRUCTURES DESIGNED TO BREAK WAVES AND ENCOURAGE SEDIMENT ACCRETION

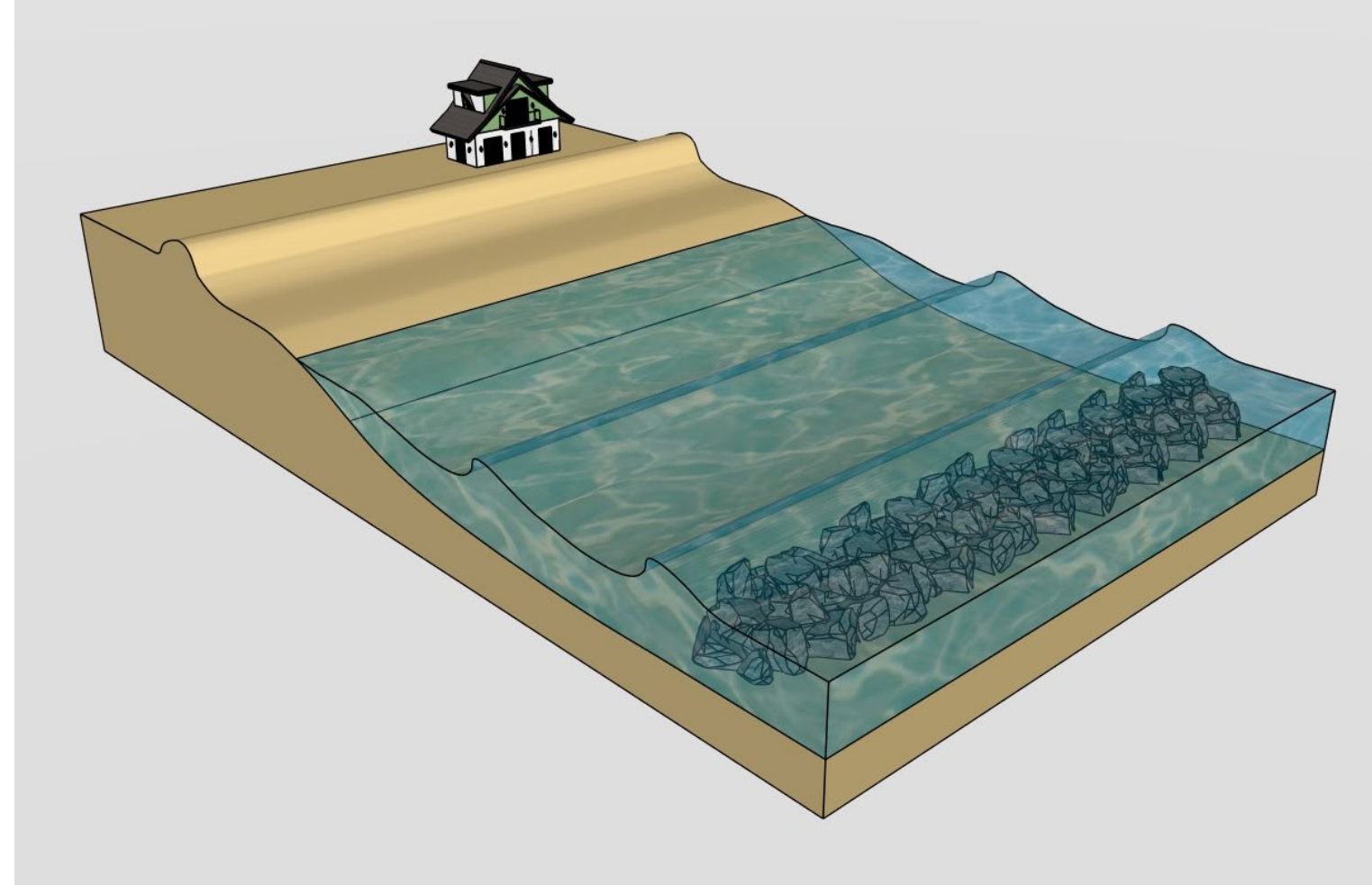

- Due to the Atlantic Ocean being highly energetic, generally not a practical option along the open coastline except in targeted hotspot locations
- Would need to be massive in scale to effectively withstand storm forces and everyday high-energy conditions and extend for miles alongshore
- Require extensive permitting and design efforts to optimize siting and minimize impacts, which in turn carries high costs
- Do not directly maintain or enhance the beach resource and may negatively impact in-water recreation activities
- Disrupts natural sediment transport and may starve other sections of shoreline of sand

GROINS

ROCK STRUCTURES PERPENDICULAR TO SHORE INTENDED TO SLOW LONGSHORE SAND TRANSPORT

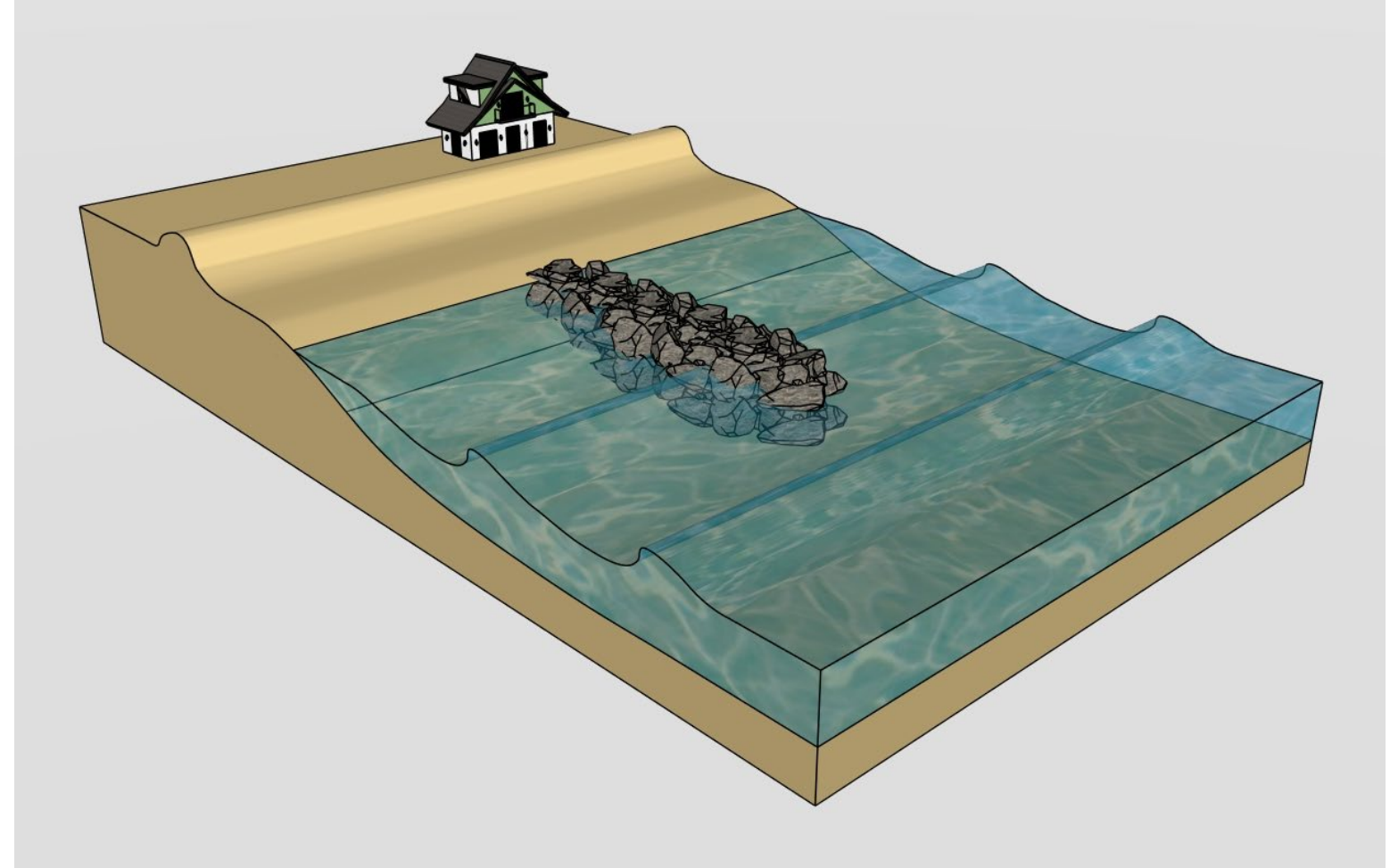

- Built perpendicular to shore to help alleviate erosion of sediment in the alongshore direction
- Typically lead to a cusped shoreline, trapping sand on the updrift side of the structure while often inducing erosion on the downdrift side of the structure
- Do not directly maintain or enhance the beach resource
- May cause significant adverse impacts to adjacent shorelines, including downdrift erosion
- Can create ecological impacts, especially for nesting turtles
- Require extensive permitting and design efforts to optimize siting and minimize impacts, which in turn carries high costs
- May pose hazards to swimmers and other beach users

NEARSHORE ARTIFICIAL REEFS

COMPONENTS INTENDED TO ENHANCE BIODIVERSITY, DISSIPATE WAVES, AND ENCOURAGE SEDIMENT ACCRETION

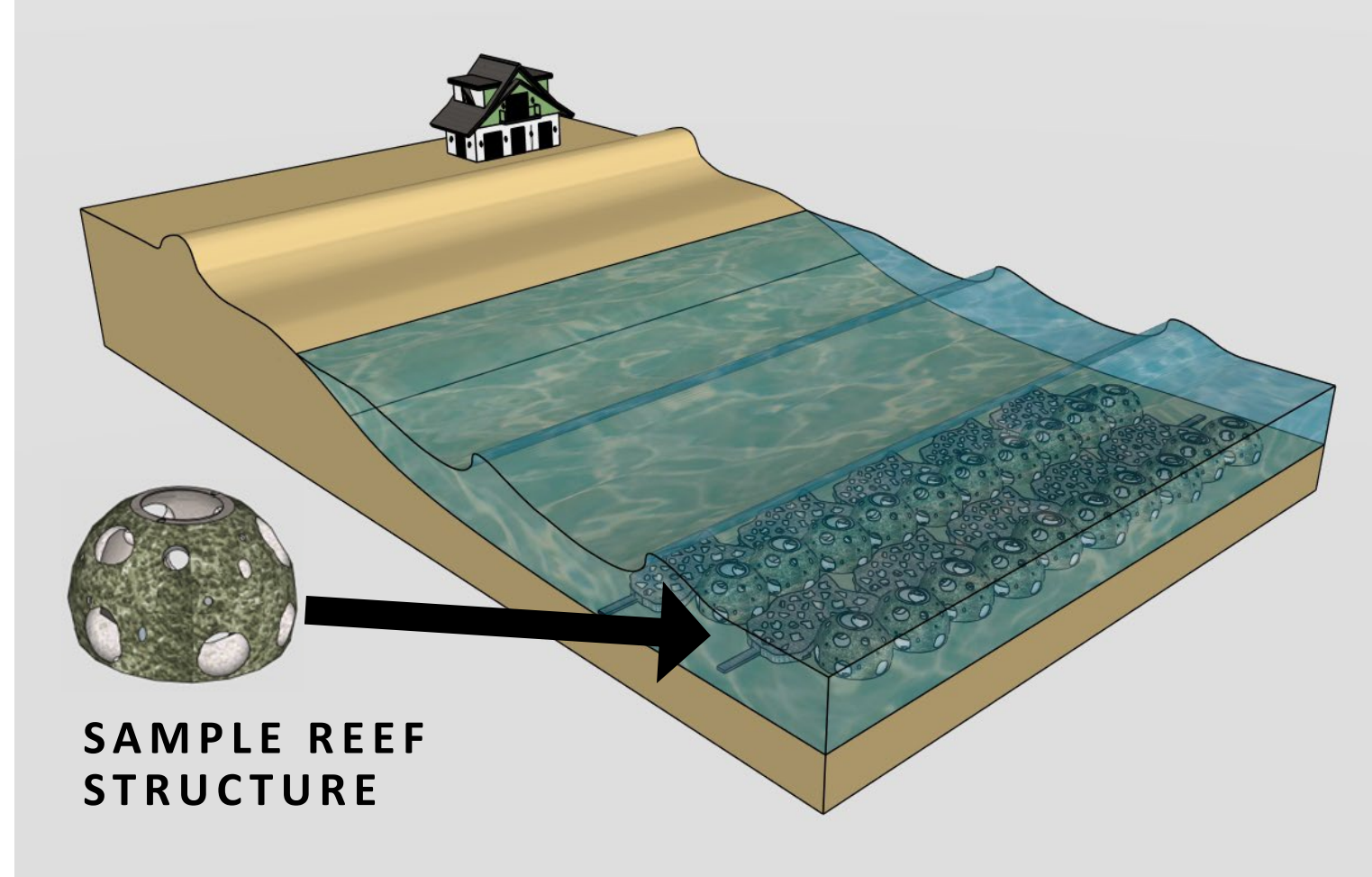

- Primary function is habitat enhancement, not shoreline protection
- Would need to be massive in scale to effectively withstand storm forces and everyday high-energy conditions and extend for miles alongshore
- Require extensive permitting and design efforts to optimize siting and minimize impacts, which in turn carries high costs
- Do not directly maintain or enhance the beach resource and may negatively impact in-water recreation activities
- Disrupts natural sediment transport and may starve other sections of shoreline of sand

SUMMARY & RECOMMENDATIONS

PLANNING SECTOR 1 HIGHLIGHTS

2.0 miles of shoreline R-1 to R-11
 public land zoning
3 public beach access points (1.5 per mile)
100% of shoreline is designed as critically eroded (FDEP, 2025)

BEACH CONDITION (2019-2024)

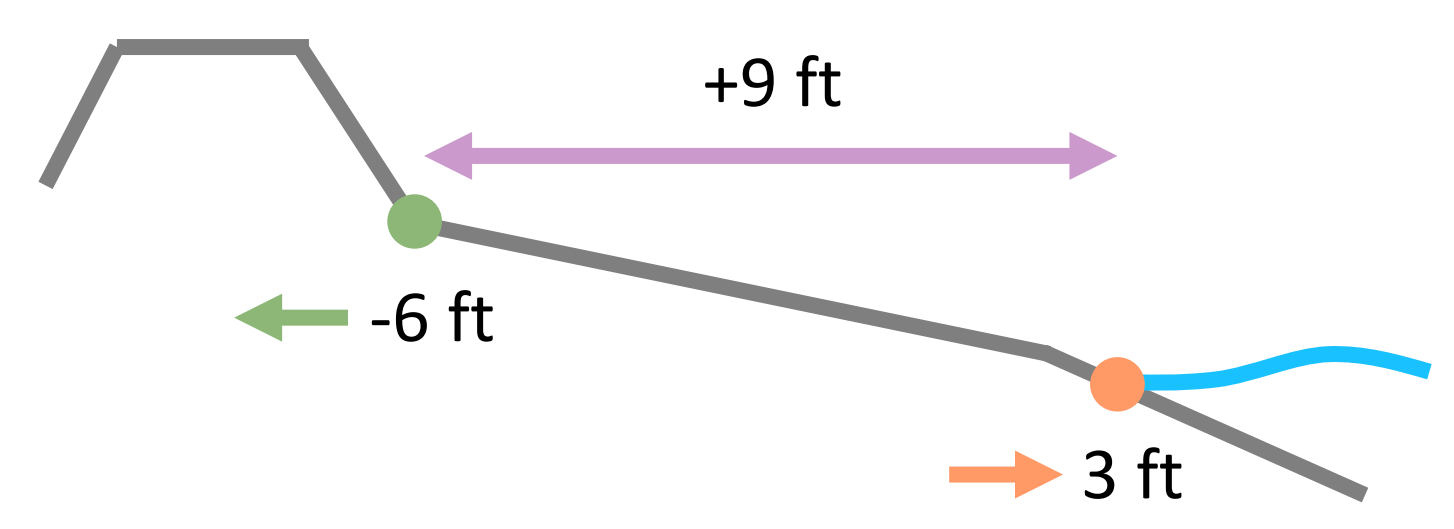

RECOMMENDED MANAGEMENT ACTION



continue sediment bypassing

PLANNING SECTOR 2 HIGHLIGHTS

1.1 miles of shoreline R-11 to R-17
 residential public land zoning
1 public beach access points (0.9 per mile)
100% of shoreline is designed as critically eroded (FDEP, 2025)

BEACH CONDITION (2019-2024)

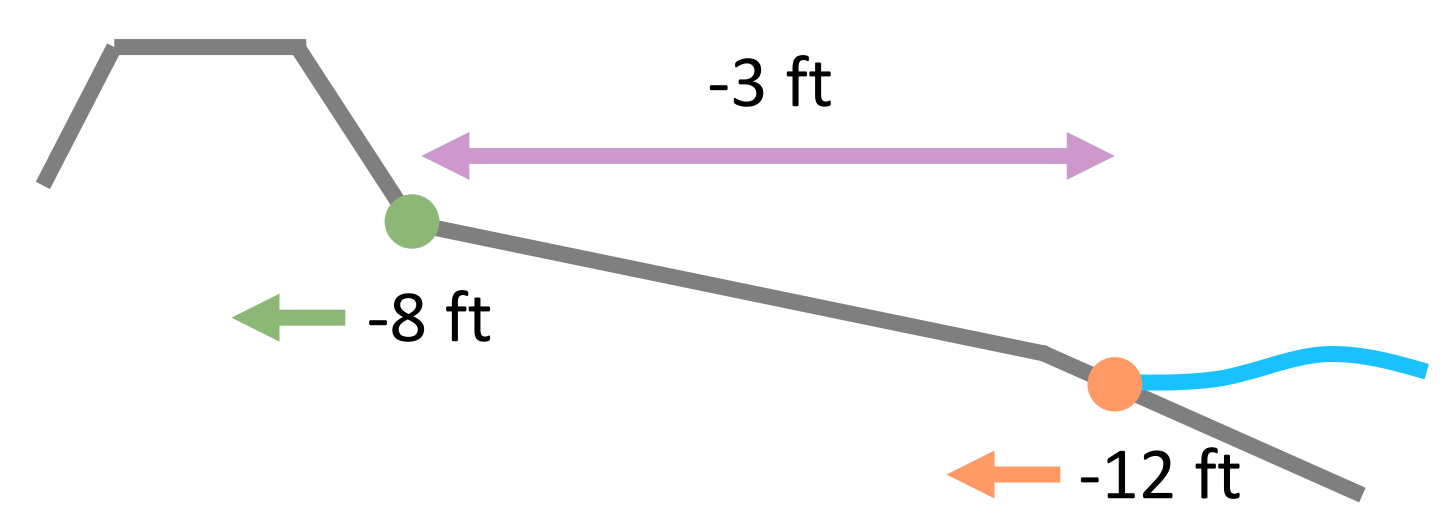

RECOMMENDED MANAGEMENT ACTION



continue sediment bypassing

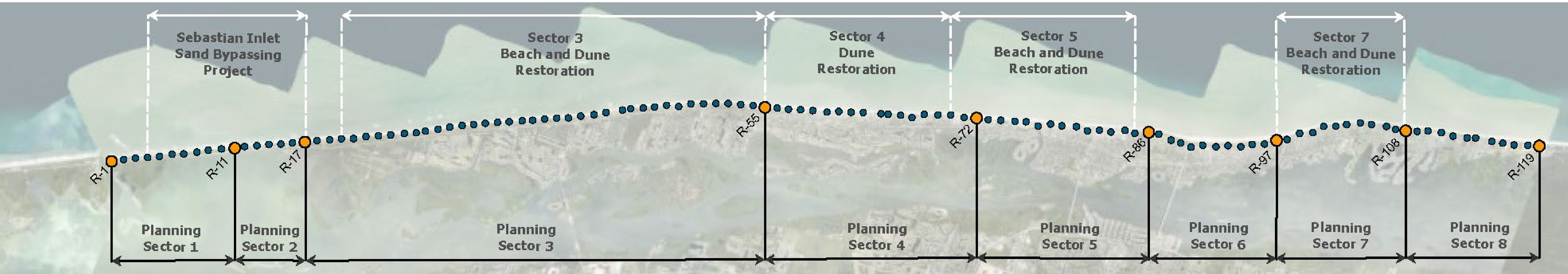

PLANNING SECTOR 3 HIGHLIGHTS

7.1 miles of shoreline R-17 to R-55
 residential commercial public land zoning
5 public beach access points (0.7 per mile)
100% of shoreline is designed as critically eroded (FDEP, 2025)

BEACH CONDITION (2019-2024)

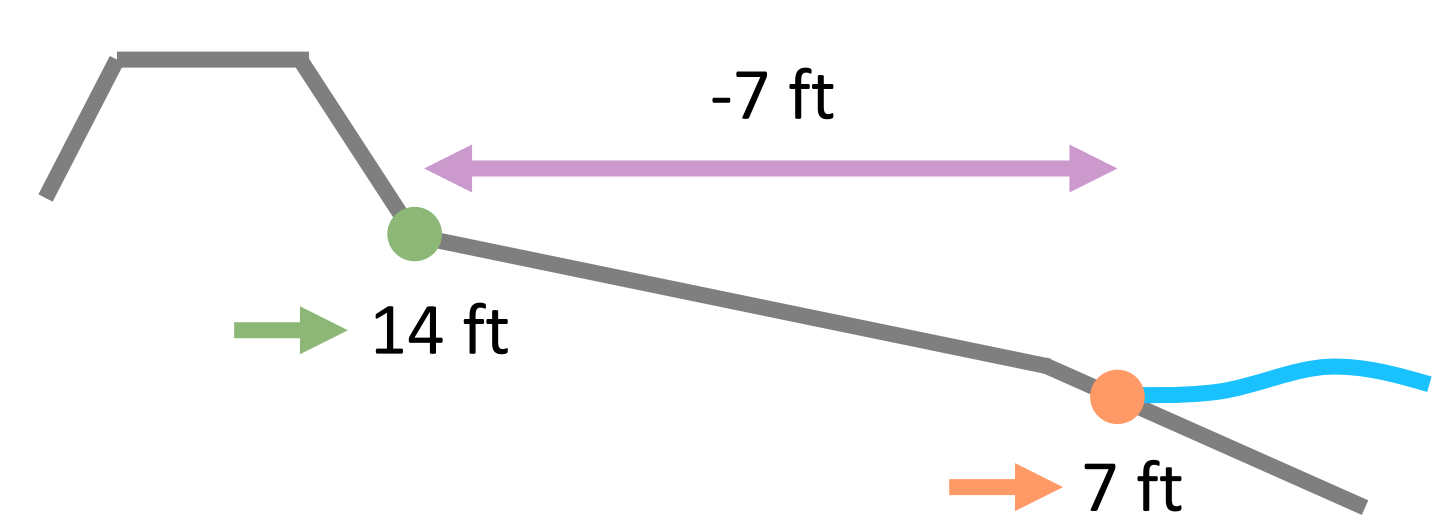

RECOMMENDED MANAGEMENT ACTION



continue beach and dune nourishment

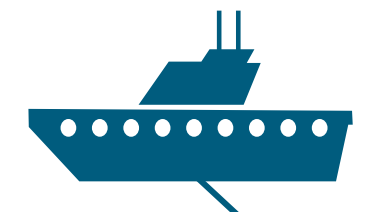

could consider impacting beach nourishment design in future

PLANNING SECTOR 4 HIGHLIGHTS

3.3 miles of shoreline R-55 to R-72
 residential land zoning
1 public beach access points (0.3 per mile)
100% of shoreline is designed as critically eroded (FDEP, 2025)

BEACH CONDITION (2019-2024)

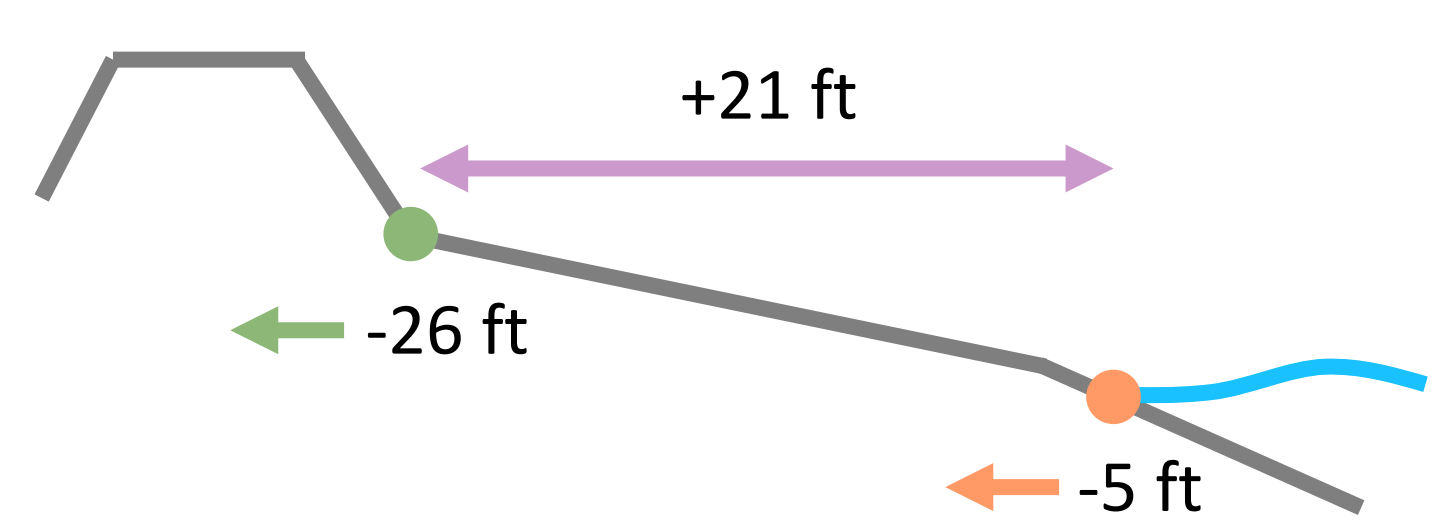

RECOMMENDED MANAGEMENT ACTION



continue beach and dune nourishment

SUMMARY & RECOMMENDATIONS

PLANNING SECTOR 5 HIGHLIGHTS

2.7 miles of shoreline (R-72 to R-86) | residential, commercial, public land zoning | **8** public beach access points (3.0 per mile) | **100%** of shoreline is designed as critically eroded (FDEP, 2025)

BEACH CONDITION (2019-2024)

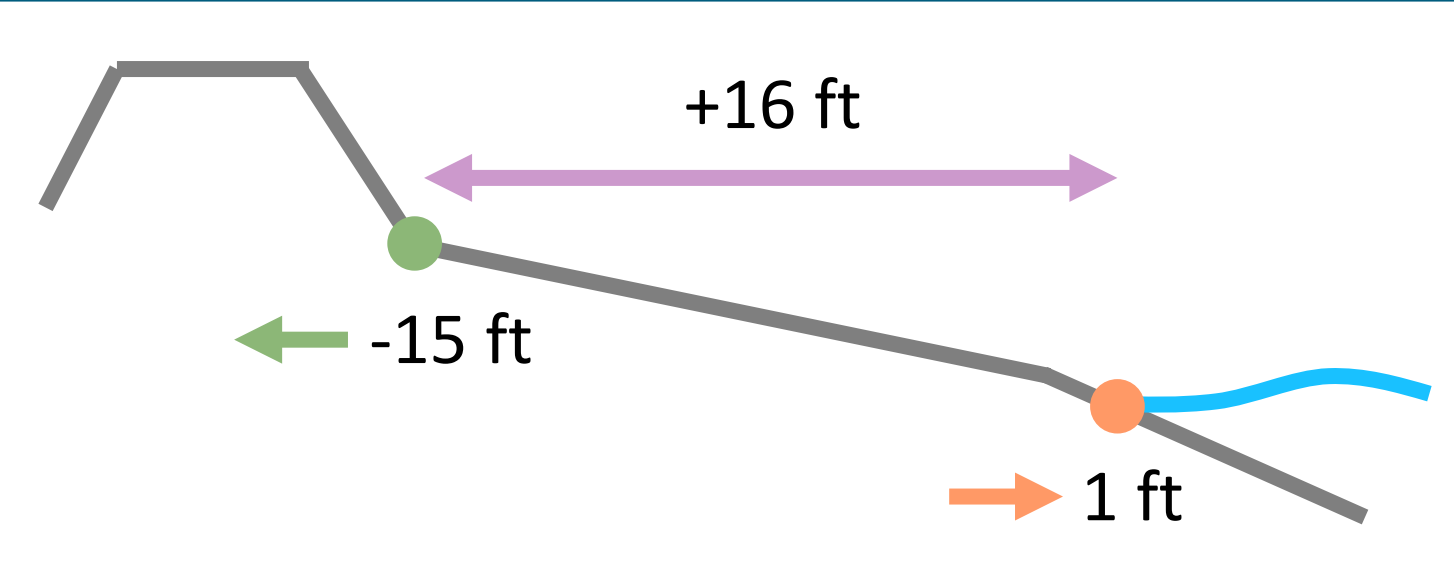

RECOMMENDED MANAGEMENT ACTION

continue beach and dune nourishment | could consider impacting beach nourishment design in future

PLANNING SECTOR 6 HIGHLIGHTS

2.0 miles of shoreline (R-86 to R-97) | residential, commercial, public land zoning | **7** public beach access points (3.6 per mile) | **0%** of shoreline is designed as critically eroded (FDEP, 2025)

BEACH CONDITION (2019-2024)

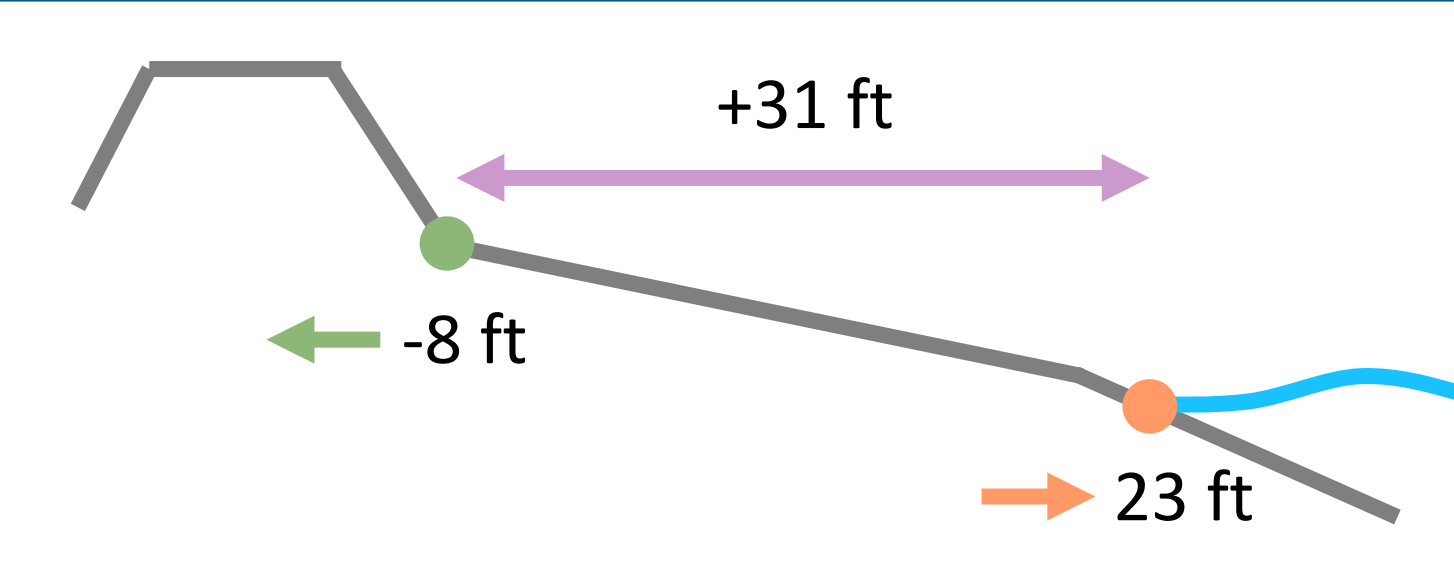

RECOMMENDED MANAGEMENT ACTION

continue to monitor and maintain dune vegetation

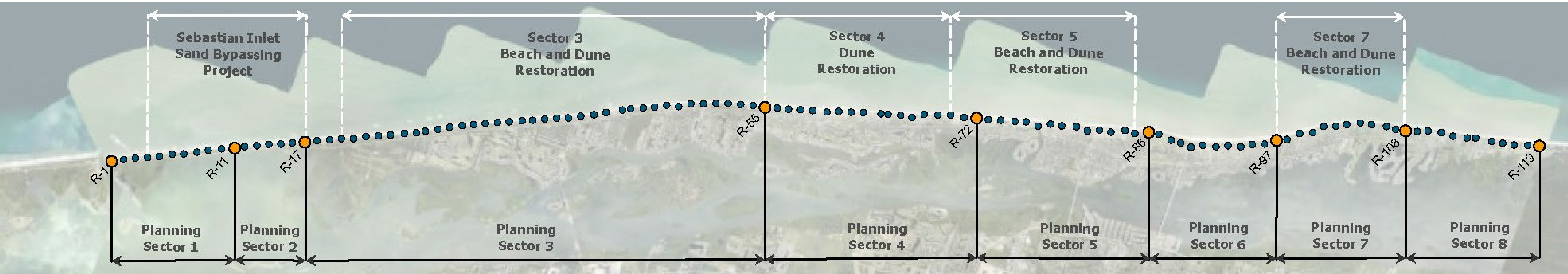

PLANNING SECTOR 7 HIGHLIGHTS

2.0 miles of shoreline (R-97 to R-108) | residential land zoning | **0** public beach access points (0 per mile) | **82%** of shoreline is designed as critically eroded (FDEP, 2025)

BEACH CONDITION (2019-2024)

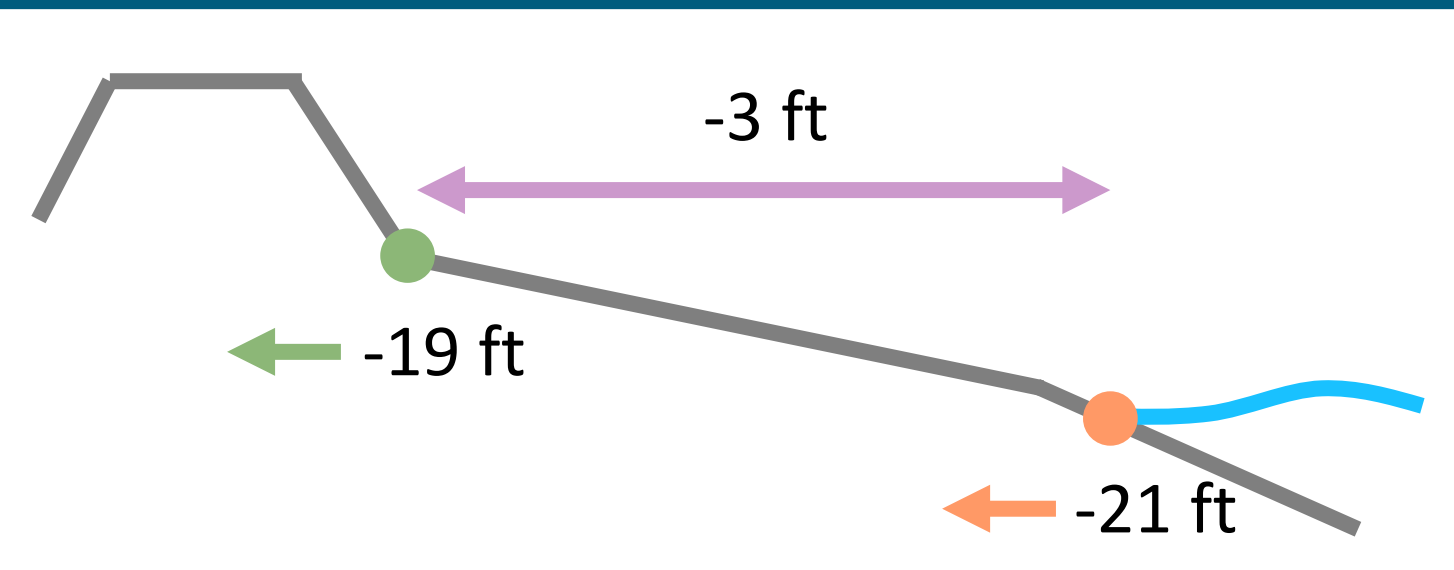

RECOMMENDED MANAGEMENT ACTION

no action without community support | implement beach and dune nourishment | could consider structural measures paired with nourishment in future

PLANNING SECTOR 8 HIGHLIGHTS

2.2 miles of shoreline (R-108 to R-119) | residential, public land zoning | **1** public beach access points (0.5 per mile) | **66%** of shoreline is designed as critically eroded (FDEP, 2025)

BEACH CONDITION (2019-2024)

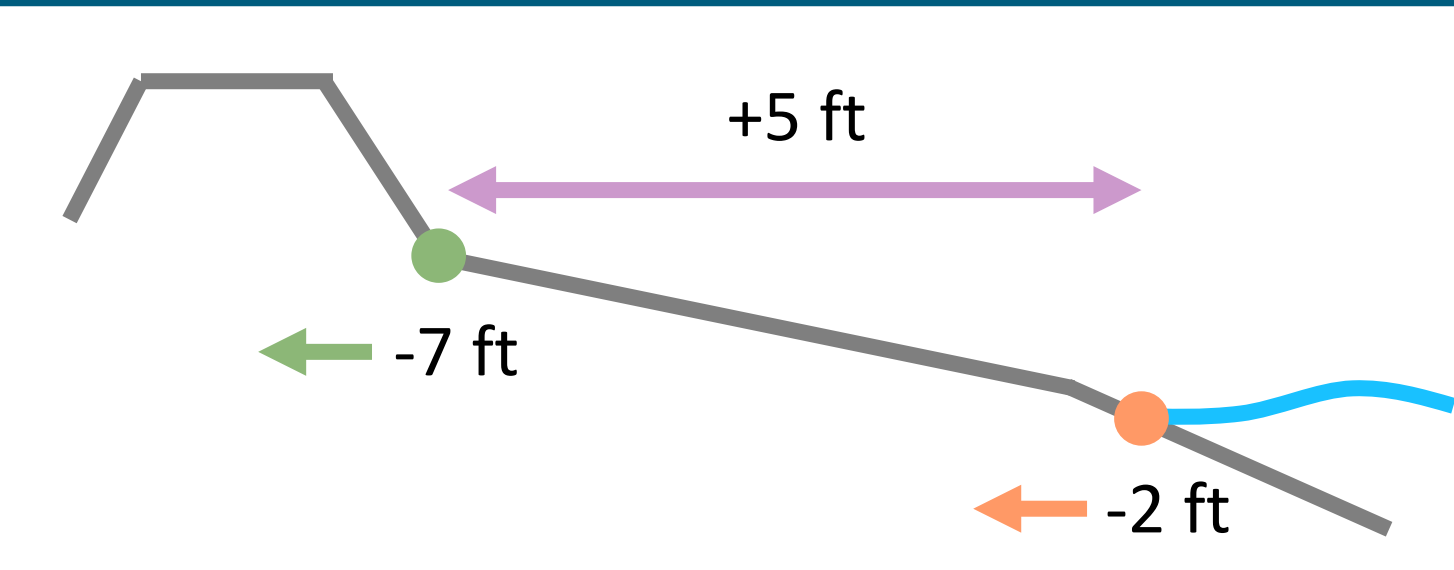

RECOMMENDED MANAGEMENT ACTION

continue to monitor and maintain dune vegetation



AGENDA ITEM

TO: Town Council

FROM: James Harpring, Town Manager

DATE: April 10, 2026

SUBJECT: Ordinance No. 590 (Second Reading)
Repeal of Article VI, Section 30.45, Code of Ordinances

BACKGROUND:

Article VI, Section 30.45, Code of Ordinances, outlines the organization, powers and duties of the Department of Treasury. The repeal of this provision is consistent with the reorganization of departments, elimination of the Department of Treasury and establishment of the Finance Department.

RECOMMENDATION:

Approve Ordinance No. 590 – Repeal of Article VI, Section 30.45 – Department of Treasury

ATTACHMENTS:

1. Ordinance No. 590



ORDINANCE NO. 590

AN ORDINANCE OF THE TOWN OF INDIAN RIVER SHORES REPEALING ARTICLE VI, SECTION 30.45, OF THE TOWN'S CODE OF ORDINANCES WHICH OUTLINES THE ORGANIZATION, POWERS AND DUTIES OF THE DEPARTMENT OF TREASURY IN ITS ENTIRETY; PROVIDING FOR APPLICABILITY AND INCLUSION; PROVIDING FOR SEVERABILITY; PROVIDING FOR AN ECONOMIC IMPACT ESTIMATE; PROVIDING FOR SCRIVENER'S ERRORS AND PROVIDING FOR AN EFFECTIVE DATE.

WHEREAS, Article VI, Section 30.45, Code of Ordinance, outlines the organization, powers and duties of the Department of Treasury; and

WHEREAS, the repeal of this provision is necessary to provide consistency with the reorganization of department, elimination of the Department of Treasury and establishment of the Finance Department; and

NOW THEREFORE, BE IT ORDAINED by the Town Council of the Town of Indian River Shores, Florida:

SECTION 1. Revisions

Article VI, Section 30.45, Code of Ordinance, Department of the Treasury is hereby repealed in its entirety.

~~• **ARTICLE VI. -- DEPARTMENT OF TREASURY**~~

~~• **Sec. 30.45. -- Organization; powers and duties.**~~

~~(a) The department of treasury shall be under the supervision of the town treasurer.~~

~~(b) The powers and duties of the town treasurer shall be as follows:~~

~~(1) He shall have the custody of all monies of the town, and all evidences of indebtedness belonging to the town or held in trust by the town.~~

~~(2) He shall collect all monies of the town, the collection of which is not provided elsewhere by charter or ordinance.~~

~~(3) He shall receive from other officers and employees of the town all money belonging to and receivable by the town that may be collected by those officers and employees; including fines, license fees, taxes, assessments, and all other charges. All money shall be turned over to the treasurer after collection or receipt, and he shall in all cases give a receipt therefor.~~

~~(4) He shall keep and deposit all monies or funds in such manner and only in such places as the council may determine and shall report the same in detail to the town manager.~~

~~(5) He shall disburse all town funds in accordance with the provisions of statute, the charter, ordinances, and procedures to be established by the council.~~

~~(6) He shall maintain a system of accounts of the town which shall conform to any uniform system required by law and to generally accepted principles and practices of government accounting, and for the submission of monthly financial statements to the council.~~

~~(7) He shall provide protection for the assets of the municipality to the extent of establishing and maintaining adequate internal control and auditing, and assuring proper insurance coverage.~~

~~(8) He shall perform such other duties as may be prescribed for him by charter, ordinance, or by the council.~~

~~(Ord. No. 285, 6-23-83)~~

SECTION 2. Business Impact Statement

Pursuant to Section 166.041 (4), Florida Statutes, the Town is required to prepare a business impact estimate for this proposed ordinance. The proposed ordinance does not fall within one of the identified exceptions for a Business Impact Estimate. However, there is no direct economic on private, for-profit businesses in the municipality by this proposed ordinance. The purpose of Ordinance No. 590 to safeguard the public health, safety and welfare of the residents of the Town by ensuring the administrative and operational structure of the Town is commensurate with the needs of the residents.

SECTION 3. Conflicts

All ordinance or parts of Ordinances in conflict with any of the provisions of this Ordinance are hereby repealed to the extent of the conflict.

SECTION 4. Severability

In the event that any portion of this Ordinance is determined to be invalid, illegal, or unconstitutional by a court of competent jurisdiction, such a decision shall in no matter affect the remaining portions of sections of this Ordinance which shall remain in full force and effect.

SECTION 5. Effectivity

This Ordinance shall take effect as provided by state law within ten (10) days of adoption.

1st Reading: March 26, 2026

Published: April 9, 2026

2nd Reading: April 23, 2026

I HEREBY CERTIFY that the foregoing Ordinance was approved by the Town Council of the Town of Indian River Shores, Florida, upon second and final reading this 23rd day of April, 2026.

Brian T. Foley, Mayor

Attest:

Janice C. Rutan, Town Clerk



THE TOWN OF *INDIAN RIVER SHORES*

AGENDA ITEM

TO: Town Council

FROM: James Harpring, Town Manager

DATE: April 10, 2026

SUBJECT: Ordinance No. 591 (Second Reading)
Amendment to Section 30.50, Code of Ordinances

BACKGROUND:

Section 30.50, Code of Ordinances, outlines the organization, powers and duties of the Department of Finance. The amendment of this provision is consistent with the reorganization of departments, elimination of the Department of Treasury and establishment of the Finance Department.

RECOMMENDATION:

Approve Ordinance No. 591 – Amendment to Section 30.50 – Code of Ordinances

ATTACHMENTS:

1. Ordinance No. 591



6001 Highway A1A • Indian River Shores, FL 32963 • (772) 231-1771 • www.irshores.com

To provide a high level of personal service with integrity and professionalism to ensure an unparalleled quality of life.

ORDINANCE NO. 591

AN ORDINANCE OF THE TOWN OF INDIAN RIVER SHORES AMENDING ARTICLE VI, SECTION 30.50, OF THE TOWN'S CODE OF ORDINANCES WHICH OUTLINES THE POWERS AND DUTIES OF THE DEPARTMENT OF FINANCE; PROVIDING FOR APPLICABILITY AND INCLUSION; PROVIDING FOR SEVERABILITY; PROVIDING FOR AN ECONOMIC IMPACT ESTIMATE; PROVIDING FOR SCRIVENER'S ERRORS AND PROVIDING FOR AN EFFECTIVE DATE.

WHEREAS, Article VI, Section 30.50, Code of Ordinance, is being amended to outline the organization, powers and duties of the Department of Finance; and

WHEREAS, the proposed amendments are consistent with the reorganization of departments, the elimination of the Department of Finance and the Department of Treasury and the establishment of the Finance Department; and

NOW THEREFORE, BE IT ORDAINED by the Town Council of the Town of Indian River Shores, Florida:

SECTION 1. Revisions

Article VI, Section 30.50, Code of Ordinance, Department of Finance is hereby amended as follows:

- **ARTICLE VII. - ~~DEPARTMENT OF FINANCE~~ DEPARTMENT**
- **Sec. 30.50. - Organization; powers and duties.**

(a) ~~The department of finance~~ Finance Department shall be headed by the ~~town manager~~ Finance Director, who also serves as the Chief Financial Officer ~~as director of finance.~~ ~~who shall, with the objective~~ The Finance Director shall ensure that the financial interests of the town shall at all times be protected, be responsible for financial planning, budgeting, and reporting duties as required by ordinance or state law, and control, except insofar as the duties of the town treasurer are regulated by ordinance or state law.

(b) The powers and duties of the ~~town treasurer~~ Finance Director shall be as follows:

(1) ~~He shall h~~Have the custody of all monies of the town, and all evidences of indebtedness belonging to the town or held in trust by the town.

(2) ~~He shall c~~Collect all monies of the town, the collection of which is not provided elsewhere by charter or ordinance.

(3) ~~He shall r~~Receive from other officers and employees of the town all money belonging to and receivable by the town that may be collected by those officers and employees; including fines, license fees, taxes, assessments, and all other charges. All money shall be turned over to the ~~treasurer after collection or~~ Finance Director after collection or receipt, and ~~he~~ the Finance Director shall in all cases give a receipt therefor.

(4) ~~He shall~~ Keep and deposit all monies or funds in such manner and only in such places as the council may determine and shall report the same in detail to the Town Manager.

(5) ~~He shall d~~Disburse all town funds in accordance with the provisions of statute, the charter, ordinances, and procedures to be established by the council.

(6) ~~He shall m~~Maintain a system of accounts of the town which shall conform to any uniform system required by law and to generally accepted principles and practices of government accounting, and for the submission of monthly financial statements to the council.

(7) ~~He shall p~~Provide protection for the assets of the municipality to the extent of establishing and maintaining adequate internal control and auditing, and assuring proper insurance coverage.

(8) ~~He shall p~~Perform such other duties as may be prescribed for him by charter, ordinance, or by the Town Council.

(c) The Finance Director shall be the purchasing officer, who shall make all purchases required by the various departments, boards, commissions, offices, and institutions of the town, except as otherwise provided by this Code.

(d) Any provision of the Code of Ordinances setting forth duties and responsibilities of the director of finance shall hereafter be delegated to the ~~department of finance~~ Finance Director.

(e) Any provision of the Code of Ordinances setting forth duties and responsibilities of the purchasing officer or Town Treasurer shall hereafter be delegated to the ~~department of finance~~ Finance Director.

SECTION 2. Business Impact Statement

Pursuant to Section 166.041 (4), Florida Statutes, the Town is required to prepare a business impact estimate for this proposed ordinance. The proposed ordinance does not fall within one of the identified exceptions for a Business Impact Estimate. However, there is no direct economic on private, for-profit businesses in the by this proposed ordinance. The purpose of Ordinance No. 591 is to safeguard the public health, safety and welfare of the residents of the Town by ensuring the administrative and operational structure of the Town is commensurate with the needs of the residents.

SECTION 3. Conflicts

All ordinance or parts of Ordinances in conflict with any of the provisions of this Ordinance are hereby repealed to the extent of the conflict.

SECTION 4. Severability

In the event that any portion of this Ordinance is determined to be invalid, illegal, or unconstitutional by a court of competent jurisdiction, such a decision shall in no matter affect the remaining portions of sections of this Ordinance which shall remain in full force and effect.

SECTION 5. Effectivity

This Ordinance shall take effect as provided by state law within ten (10) days of adoption.

1st Reading: March 26, 2026

Published: April 9, 2026

2nd Reading: April 23, 2026

I HEREBY CERTIFY that the foregoing Ordinance was approved by the Town Council of the Town of Indian River Shores, Florida, upon second and final reading this 23rd day of April, 2026.

Brian T. Foley, Mayor

Attest:

Janice C. Rutan, Town Clerk



THE TOWN OF *INDIAN RIVER SHORES*

AGENDA ITEM

TO: Town Council

FROM: James Harpring, Town Manager

DATE: April 10, 2026

SUBJECT: Ordinance No. 592 (Second Reading)
Amendment to Section 32.21, Town Manager

BACKGROUND:

Section 32.21, Code of Ordinances outlines various duties and responsibilities of the Town Manager. Recommended amendments include deletion of reference to a “Clerk-Treasurer”, “Engineer”, “Superintendent of Public Works”, “Purchasing Officer”, “Chief of Police”, “Fire Chief,” and “Personnel Director”. Changes also clarify the designation of acting Town Manager and repeal of any prior designations of acting, deputy or interim Town Manager.

RECOMMENDATION:

Approve Ordinance No. 592 – Amendment to Article II, Section 32.21, Code of Ordinances

ATTACHMENTS:

Ordinance No. 592 - Amendment to Article II, Section 32.21, Town Manager



6001 Highway A1A • Indian River Shores, FL 32963 • (772) 231-1771 • www.irshores.com

To provide a high level of personal service with integrity and professionalism to ensure an unparalleled quality of life.

ORDINANCE NO. 592

AN ORDINANCE OF THE TOWN OF INDIAN RIVER SHORES AMENDING ARTICLE II, SECTION 32.21, OF THE TOWN'S CODE OF ORDINANCES WHICH OUTLINES THE POWERS AND DUTIES OF THE TOWN MANAGER; PROVIDING FOR APPLICABILITY AND INCLUSION; PROVIDING FOR SEVERABILITY; PROVIDING FOR AN ECONOMIC IMPACT ESTIMATE; PROVIDING FOR SCRIVENER'S ERRORS AND PROVIDING FOR AN EFFECTIVE DATE.

WHEREAS, Article II, Section 32.21, Code of Ordinance, is being amended to outline the organization, powers and duties of the Town Manager; and

WHEREAS, the proposed amendments include deletion of reference to a "Clerk-Treasurer", "Engineer", "Superintendent of Public Works", "Purchasing Officer", "Chief of Police", "Fire Chief," and Personnel Director, clarification of the designation of acting Town Manager and repeal of any prior designations of acting, deputy or interim Town Manager; and

NOW THEREFORE, BE IT ORDAINED by the Town Council of the Town of Indian River Shores, Florida:

SECTION 1. Revisions

Article II, Section 32.21, Code of Ordinance, Department of Finance is hereby amended as follows:

Sec. 32.21. Town Manager.

- (a) *Appointment.* There is hereby created the office of Town Manager. The Town Council shall appoint a nonelected officer who shall have the title of Town Manager and shall have the powers and perform the duties as set forth in this section. The Town Manager shall hold office at the pleasure of the Town Council. The salary of the Town Manager shall be determined by the Town Council.
- (b) *Removal.* The Town Council may remove the Town Manager by a majority vote of its members.
- (c) *Supervision of Town departments.* All Town departments shall be under the supervision of the Town Manager.
- (d) *Council not to interfere.* Neither the Council nor any of its members shall direct or request the appointment of any person to, or his removal from, office by the Town Manager or by any of his subordinates, or in any manner take part in the appointment or removal of officers and employees in the administrative service of the Town. Except for purposes of inquiry, the Council and its members shall deal with the administrative service solely through the Town Manager and neither the Council nor any member thereof shall give orders to any subordinate of the Town Manager, either publicly or privately.
- (e) *Qualifications.* The Town Manager shall be chosen by the Council solely on the basis of his executive and administrative qualifications with special reference to his actual experience or his knowledge, accepted practice in respect to the duties of his office as herein set forth.

- (f) *Powers and duties, generally.* The duties, authorities and responsibilities of the Town Manager are as follows:
- (1) He shall be the Chief Administrative Officer of the Town and responsible only to the Town Council.
 - (2) He shall supervise the enforcement of all laws and ordinances.
 - (3) ~~He shall be responsible for the performance of all of the duties of the engineer, Superintendent of Public Works, and Purchasing Officer, and shall be vested with the authorities of such offices. He may from time to time delegate certain of these duties and subject to confirmation by the Town Council create separate administrative officers or deputy administrative officers to assume such duties.~~
 - (4) He shall be responsible for the preparation of the budget as prescribed by the Town Charter.
 - (5) ~~The Clerk-Treasurer shall be appointed by and sit at the pleasure of the Town Council. The Clerk-Treasurer shall be under the administrative direction of the Town Manager insofar as such direction is not inconsistent with the Charter and ordinance provisions as to the powers and duties of the Clerk-Treasurer.~~
 - (6) The Town Manager shall promote the public peace, health and safety of persons and property, and shall direct the Chief of Police, Fire Chief or the Public Safety Director in the manner and method of maintaining the same.
 - (7) Except as otherwise provided in this code, he shall manage and supervise all public improvements, works and undertakings of the Town. He shall have charge of the construction, repair, maintenance, cleaning and lighting of streets, sidewalks, bridges, pavements, sewers and all public buildings or other property belonging to the Town. He shall manage and supervise all Town utilities and shall be responsible for the preservation of all Town property.
 - (8) He shall enforce all terms and conditions imposed in favor of the Town or its inhabitants in any public utility franchise or in any contract.
 - (9) He shall attend all meetings of the Town Council, with the right to take part in discussions, but without the right to vote.
 - (10) He shall be a member, ex officio, of all committees of the Town Council.
 - (11) He shall recommend to the Town Council for adoption such measures as he may deem necessary or expedient.
 - (12) He shall be responsible to the Town Council for the efficient administration of all departments of the Town Government.
 - (13) He shall assume all the duties and responsibilities ~~as Personnel Director of all Town employees~~ regarding Human Resources. He may delegate such duties to some other officer or employee of the Town but shall not relieve him of any responsibility for the proper conduct of such duties.
 - (14) He shall exercise and perform all administrative functions of the Town that are not imposed upon some other official.
 - (15) He shall perform such other duties as may be required of him by ordinance or by the direction of the Town Council.

(g) *Absence or disability.* During ~~the any planned temporary absence or disability~~ of the Town Manager, ~~the Mayor may act in his place~~ the Town Manager may appoint the Town Clerk or any department director to serve as Acting Town Manager. The designation by the Town Manager of an Acting Town Manager shall be in writing with the term of the appointment noted. In the event of an absence or disability for more than 30 days, the Town Council may declare the office of Town Manager vacant and choose a successor. Any prior designation by either the Town Manager or Town Council of an Acting Town Manager, Deputy Town Manager or Interim Town Manager are repealed.

SECTION 2. Business Impact Statement

Pursuant to Section 166.041 (4), Florida Statutes, the Town is required to prepare a business impact estimate for this proposed ordinance. The proposed ordinance does not fall within one of the identified exceptions for a Business Impact Estimate. However, there is no direct economic on private, for-profit businesses in the by this proposed ordinance. The purpose of Ordinance No. 592 is to safeguard the public health, safety and welfare of the residents of the Town by ensuring the administrative and operational structure of the Town is commensurate with the needs of the residents.

SECTION 3. Conflicts

All ordinance or parts of Ordinances in conflict with any of the provisions of this Ordinance are hereby repealed to the extent of the conflict.

SECTION 4. Severability

In the event that any portion of this Ordinance is determined to be invalid, illegal, or unconstitutional by a court of competent jurisdiction, such a decision shall in no matter affect the remaining portions of sections of this Ordinance which shall remain in full force and effect.

SECTION 5. Effectivity

This Ordinance shall take effect as provided by state law within ten (10) days of adoption.

1st Reading: March 26, 2026

Published: April 9, 2026

2nd Reading: April 23, 2026

I HEREBY CERTIFY that the foregoing Ordinance was approved by the Town Council of the Town of Indian River Shores, Florida, upon second and final reading this 23rd day of April, 2026.

Brian T. Foley, Mayor

Attest:

Janice C. Rutan, Town Clerk



AGENDA ITEM

TO: Town Council

FROM: James Harpring, Town Manager

DATE: April 10, 2026

SUBJECT: Ordinance No. 593 (Second Reading)
Amendment to Section 31.02, Procurement of goods and service.

BACKGROUND:

Section 31.02, Code of Ordinances outlines procedures for the procurement of goods and services. Currently, Section 31.02 (a) (1) authorizes the Purchasing Agent to purchase materials, equipment, services and supplies up to \$10,000. Section 31.02 (b)(1) provides for the Purchasing Agent to have authority to cooperate with local governments and other public entities in development of procurement contracts or master agreements. Similarly, section 31.02 (b) (2) authorizes the Purchasing Agent, or Town Manager, to have the authority over utilizing contracts or master agreements of state, federal or other local governments or other public entities to procure goods, or services, if the contract has been awarded through procedures equivalent to the requirements of this section (piggybacking) and authorizes the Purchasing Officer to procure goods and services in accordance with the dollar threshold established by Ordinance. Also, section 31.02 (b) (3) allows contracts for professional services, upon approval by the Town Manager or the Town Council, depending on value, be entered without competitive bidding. Also, section 31.02 (b)(4) provides for a “sole source” process whereby a contract may be awarded without competitive bids. Currently, the Purchasing Agent or Purchasing Officer or designee is the staff member that may provide written documentation asserting only one practical source for the desired item. Finally, section 31.02 (b)(5) provides for emergency purchases with the authority for this designation resting with the Purchasing Agent.

The amendments designate the Town Manager, or designee, as the authorizing authority for these items.

RECOMMENDATION:

Approve Ordinance No. 593 – Amendment to Section 31.02, (a) (1), Section 31.02 (b)(1), Section 31.02 (b)(2), Section 31.02 (b)(3), Section 31.02 (b)(4), and Section 31.02 (b)(5), Code of Ordinances.

ATTACHMENTS:

Ordinance No. 593 - Amendments to Section 31.02, (a) (1), Section 31.02 (b)(1), Section 31.02 (b)(2), Section 31.02 (b)(3), Section 31.02 (b)(4), and Section 31.02 (b)(5), Code of Ordinances.



ORDINANCE NO. 593

AN ORDINANCE OF THE TOWN OF INDIAN RIVER SHORES AMENDING ARTICLE 31.02, OF THE TOWN'S CODE OF ORDINANCES WHICH OUTLINES THE PROCEDURES FOR THE PROCUREMENT OF GOODS AND SERVICES; PROVIDING FOR APPLICABILITY AND INCLUSION; PROVIDING FOR SEVERABILITY; PROVIDING FOR AN ECONOMIC IMPACT ESTIMATE; PROVIDING FOR SCRIVENER'S ERRORS AND PROVIDING FOR AN EFFECTIVE DATE.

WHEREAS, Chapter 31, Section 31.02, Code of Ordinance, outlines procedures for the procurement of goods and services, and;

WHEREAS, Section 31.02 (a) (1) provides for the Purchasing Agent to authorize the purchase of materials, equipment, services and supplies up to &10,000, and;

WHEREAS, Section 31.02 (b) (1) authorizes the Purchasing Agent to cooperate with local governments and other public entities in development of procurement contracts or master agreements, and;

WHEREAS, Section 31.02 (b) (2) authorizes the Purchasing Agent, or Town Manager, to have the authority over utilizing contracts or master agreements of state, federal or other local governments or other public entities to procure goods, or services, if the contract has been awarded through procedures equivalent to the requirements of this section and authorizes the Purchasing Officer or procure goods and services in accordance with the dollar threshold established by Ordinance, and;

WHEREAS, Section 31.02 (b) (3) allows contracts for professional services, upon approval by the Town Manager or the Town Council, depending on value, be entered without competitive bidding, and;

WHEREAS, Section 31.02 (b) (4) also provides for a "sole source" process whereby a contract may be awarded without competitive bids and currently the Purchasing Agent or designee is the staff member that may provide written documentation asserting only one practical source for the desired item, and;

WHEREAS, Section 31.02 (b)(5) provides for emergency purchases with the authority for this designation resting with the Purchasing Agent.

NOW THEREFORE, BE IT ORDAINED by the Town Council of the Town of Indian River Shores, Florida:

SECTION 1. Revisions

Chapter 31, Sections 31.02 (a) (1), 31.02 (b) (1), Section 31.02 (b) (2), Section 31.02 (b) (3) Section 31.02 (b) (4) and Section 31.02 (b) (5) be amended to designate the Town Manager, or designee, as the authorizing authority for these items:

Sec. 31.02. Procurement of goods and service.

- (a) *Purchasing thresholds.* Any request for the purchase of materials, equipment, services and supplies unless otherwise exempt under this section is subject to competitive bid procedures as follows:
- (1) Up to \$10,000—~~The Town Purchasing Agent~~ Town Manager, or designee may authorize purchase.
 - (2) \$10,000.01 to \$35,000—The Town Manager may authorize purchase.
 - (3) Over \$35,000—Formal sealed bids and Town Council authorization are required.
- (b) *Exceptions to thresholds.*
- (1) *Joint bid.* ~~The Purchasing Agent~~ Town Manager, or designee shall have the authority to cooperate with other local governments or other public entities in the development and use of mutually cooperative procurement contracts or master agreements. Approval shall be in accordance with the dollar threshold established by this section.
 - (2) *Piggyback.* ~~The Purchasing Agent~~ or Town Manager, or designee shall have the authority to utilize contracts or master agreements of state, federal or other local governments or other public entities to procure goods and services, if the contract or agreement has been awarded through procedures substantially equivalent to the requirements of this section. ~~The Purchasing Officer~~ Town Manager, or designee shall have the authority to procure goods and services if the purchase is with a person, firm, organization, or corporation whose offer to sell to the Town is at sale price for that commodity equal to or lower than the existing piggyback price for the same or equal commodity being sought. Approval shall be in accordance with the dollar threshold established by this section.
 - (3) *Professional services.* Contracts for professional services, including, but not limited to, architects, attorneys, accountants, engineers, and surveyors, may, upon approval by the Town Manager, or designee, or the ~~Town Council~~ depending on value, be entered without competitive bidding. A review of the qualifications, work history, and other relevant data will be done before contracts for such services are entered.
 - (4) *Sole source.* A contract may be awarded for goods or services without competitive bids when the ~~Purchasing Agent~~ Town Manager, or designee provides written documentation asserting that there is only one practical source for the required item. Approval shall be in accordance with the dollar threshold established by this section.
 - (5) *Emergency purchase.* Where the ~~Purchasing Agent~~, Town Manager, or designee, finds it to be in the best interest of the Town, an emergency procurement condition may be declared, which suspends any or all provisions of this section. All emergency purchases over \$35,000 shall be reported to Council as soon as practical. As used in this section, the term "emergency" means a sudden unexpected turn of events that causes:
 - a. An immediate danger to the public health or safety;
 - b. An immediate danger of loss of public or private property;
 - c. An interruption in the delivery of an essential governmental service; or
 - d. An interruption in the normal function and operation of any Town department that would result in a work stoppage or other substantial monetary loss.

- (6) *Change orders.* The Town Manager may approve cumulative changes of up to 15 percent of the total contract price. Changes in excess of 15 percent of the total contract price or any change in excess of \$35,000 must have the prior approval of the Town Council.

SECTION 2. Business Impact Statement

Pursuant to Section 166.041 (4), Florida Statutes, the Town is required to prepare a business impact estimate for this proposed ordinance. The proposed ordinance does not fall within one of the identified exceptions for a Business Impact Estimate. However, there is no direct economic on private, for-profit businesses in the by this proposed ordinance. The purpose of Ordinance No. 593 is to safeguard the public health, safety and welfare of the residents of the Town by ensuring the administrative and operational structure of the Town is commensurate with the needs of the residents.

SECTION 3. Conflicts

All ordinance or parts of Ordinances in conflict with any of the provisions of this Ordinance are hereby repealed to the extent of the conflict.

SECTION 4. Severability

In the event that any portion of this Ordinance is determined to be invalid, illegal, or unconstitutional by a court of competent jurisdiction, such a decision shall in no matter affect the remaining portions of sections of this Ordinance which shall remain in full force and effect.

SECTION 5. Effectivity

This Ordinance shall take effect as provided by state law within ten (10) days of adoption.

1st Reading: March 26, 2026

Published: April 9, 2026

2nd Reading: April 23, 2026

I HEREBY CERTIFY that the foregoing Ordinance was approved by the Town Council of the Town of Indian River Shores, Florida, upon second and final reading this 23rd day of April, 2026.

Brian T. Foley, Mayor

Attest:

Janice C. Rutan, Town Clerk



AGENDA ITEM

TO: Town Council

FROM: James Harpring, Town Manager

DATE: April 21, 2026

SUBJECT: Award of ITB 26-01 Beachcomber Lane / Pebble Lane Stormwater, Paving and Septic to Sewer Project

BACKGROUND:

The Town is coordinating a stormwater, paving and septic to sewer project with the City of Vero Beach. The septic to sewer portion of the project is consistent with the requirements of HB 1379 (2023). The project includes Beachcomber Lane and Pebble Lane. The bid documents were issued on March 10, 2026. A mandatory pre-submittal conference took place on March 24, 2026. Bids were opened on April 15, 2026. Per the Town purchasing policy and section 255.20, Florida Statutes and section 287.057, Florida Statutes, the contract shall be awarded to the responsible and responsive vendor who submits the lowest responsive bid.

Three bids were received:

	Beachcomber Lane	Pebble Lane	Total
Jobear	1,175,410.65	1,021,491.23	2,196,901.88
Cathcart	1,202,059.10	872,737.80	2,074,796.90
GRSC	1,140,336.12	805,002.55	1,945,338.67

RECOMMENDATION:

Award ITB 26-01 to GRSC, the lowest responsive and responsible bidder, in the amount of \$1,945,338.67 and authorize the Town Manager to execute the contract documents.

ATTACHMENTS:

Bid Tabulation Sheet; Bid Proposal – GRSC, Inc.

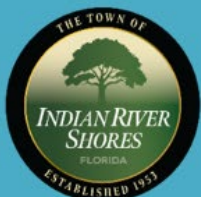

Bid Opening

ITB 26-01

Beachcomber Lane and Pebble Lane

Roadway and Sewer Project

Wednesday, April 15, 2026

2:00 PM

Sealed bids have been requested via Demand Star on March 10, 2026.

The responses were due no later than 2:00 pm on April 15, 2026, with any received after that time to be excluded from consideration.

Those present were: Town Manager James Harpring, Finance Director and Procurement Manager Heather Christmas, and Recorder Lucy Scheidt.

Submitted By	Date & Time Rec'd	Bid amount	Notes
Central Florida Construction Walls, Inc	4/14/25 3:25 PM	Unknown	Disqualified – submitted via email 04/14/2026. Proposal unopened.
Cathcart	04/15/2026 1:30 PM	\$2,074,796.90	Beachcomber \$1,202,059.10 Pebble \$872,737.80
GRSC	04/15/2026 1:39 PM	\$1,945,338.67	Beachcomber \$1,140,336.12 Pebble \$805,002.55
Jobear	4/15/26 1:49 PM	\$2,196,901.88	Beachcomber \$1,175,410.65 Pebble \$1,021,491.23

Seeing no one approaching with any more bids, the bids on hand were opened at 2:00 PM and the results recorded above. Procurement Manager Christmas announced that the anticipated award of the project would occur at the Regular Town Council Meeting on April 23, 2026.

The meeting adjourned at 2:09 PM.

s/s Lucy Scheidt



1643 NW Dove Court
Stuart, FL 34994
(772)473-2201
brad@grscinc.net

April 15, 2026

James Harpring
Town of Indian River Shores
6001 Highway A1A
Indian River Shores, FL 32963

Dear Mr. Harpring,

GRSC, Inc. is submitting a bid for ITB 26-01 Beachcomber Lane and Pebble Lane Roadway and Sewer Project. We are grateful for the opportunity to bid work for The Town and look forward to the possibility of working with your team on this project.

GRSC, Inc. is a site contractor based in Stuart, FL. We have completed public and private jobs across the State of Florida, but our main area of focus is from Indian River County to Palm Beach County. Our goal in every job is to self-perform as much of the work as possible. We employ an asphalt crew, concrete crew, and pipe crew, so the work for this project would be almost completely kept in-house. We would use a subcontractor for survey and as-builts, thermoplastic striping, and potentially for landscaping depending on the ultimate requirements.

GRSC, Inc. recently completed a LAP funded project in Martin County with a very similar scope to this project. We contract with major homebuilders for community closeout repairs on asphalt and concrete. We are experienced working in established neighborhoods and are familiar with the challenges that can arise in such situations. Every project and homeowner are different, but we feel that our experience qualifies us to complete this work for the residents of Beachcomber Lane and Pebble Lane.

Respectfully,

Gaynam Rackstraw
gaynam@grscinc.net
(772)888-6818



*Qualifications/
Experience*

1643 NW Dove Court
Stuart, FL 34994
(772) 888-6818
gaynam@grscinc.net

Professional Qualifications of Firm

GRSC, Inc. is a licensed Florida General Contractor (CGC1521059) based in Stuart, FL. We have been in business since 2012. Our work experience includes all aspects of site development including clearing, excavation, grading, drainage construction and improvements, lake excavation, asphalt paving, concrete flatwork, and underground utilities. We perform all aspects of horizontal construction for private companies and municipalities. We have done work on Florida's East Coast from Dade to Duvall County, and in Southwest Florida as well.

GRSC, Inc. got started in land/site development work with large builders including Pulte Group and K. Hovnanian, among others. We have long-standing relationships with these builders and continue to work for them today. In 2023 we began actively pursuing work with municipalities in Florida. Recently completed private and municipal projects include:

- City of Stuart Riverside Neighborhood Improvement LAP.
 - Neighborhood improvements in the Riverside Neighborhood in Stuart, FL
 - Scope included Asphalt, concrete sidewalk and curbing, drainage structures, underground utilities, street lighting, permeable paver parking, pattern pavement crosswalks, striping and signage, sod, landscaping. This was a LAP funded project.
 - Total Contract Value: \$2,167,569.88
 - Contact: Kathryn Durno 772-288-5777

- Harbor Isles Vero Beach
 - Retrofit sitework for the Harbor Isles subdivision Phase 1
 - Scope included Excavation, grading, asphalt, concrete flat work drainage, home grading
 - Total Contract Value: \$3,750,000.00
 - Contact: Fabiano Barros (561) 722-7926

- Indian River County Shooting Range - Sporting Clays Trail Improvement Project.
 - Improvements on the Indian River County Shooting Range Sporting Clays Course
 - Scope included clearing, road construction, and drainage



GRSC, INC.

1643 NW Dove Court
Stuart, FL 34994
(772) 888-6818
gaynam@grscinc.net

- Total Contract Value: \$367,130.00
- Contact: Rob Skok (772) 205-7290

- City of Parkland Pinetree Park Urban Greenway/Drainage Improvement Project.
 - Drainage Improvements for greenway park in the City of Parkland, FL.
 - Scope included clearing, swale construction, drainage structures, concrete flatwork
 - Total Contract Value: \$1,538,297.00
 - Contact: Richard Biagini (954) 757-4171

- City of Fellsmere Swales and Micro basin Project
 - Drainage improvements for the City of Fellsmere
 - Scope included drainage remediation, driveway culverts, sod, tree removal, concrete flatwork
 - Total Contract Value: \$1,082,993.75
 - Contact: Kenny Evans (772) 217-9181

- Victoria Park site development – Port St. Lucie, FL
 - Sitework for community amenity building
 - Scope included Excavation, utilities, concrete flatwork, asphalt, grading
 - Total Contract Value: \$850,000.00
 - Contact: Garfield Hartman (561) 577-1149

- Astrotech Warehouse Site Improvements – Titusville, FL
 - Sitework for aerospace warehouse facility
 - Scope included swale and pond excavation, asphalt, concrete, underground drainage, drainage structures, sod
 - Total Contract Value: \$536,000.00
 - Contact: Tom Flynn (772) 220-1930

These projects were completed concurrently and required coordination and supervision across multiple counties. GRSC, Inc. performed much of the work on these projects and employed a small group of trusted subcontractors to complete specialized tasks.



1643 NW Dove Court
Stuart, FL 34994
(772) 888-6818
gaynam@grscinc.net

GRSC, Inc. currently contracted with The City of Port St. Lucie, The City of Parkland, Indian River County, and Flagler County on civil/site work projects. We also continue to work with homebuilders along the east coast including grading, drainage, concrete flat work, paving, and community close-out. These projects require flexible project management of various projects to meet the expectations of multiple clients.

Current and Projected Workload

Current Projects:

South County Park Improvements, Indian River County

- 95% complete. Projected completion 4/31/2026
- Duck Court Park, City of Port Saint Lucie
 - 95% complete. Projected completion 4/31/2026
- IFAS Trailer Site Work, Indian River County
 - 15% complete. Projected completion 5/30/2026
- Parkland Ranches Pump Station
 - 0% complete. Projected schedule 8/1/2026 – 2/28/2027

Ongoing Work:

- Homebuilder grading services
- Homebuilder community close-out
- Indian River County Road and Bridge as-needed concrete repair

GRSC, Inc. owns the equipment that would be used for this work, and we intend to self-perform all work possible. If a project requires, we may opt to subcontract specialized work that is outside of our core competency. This decision would be made based on adherence to The County's schedule, company asset disposition, and labor availability. Our goal and intent are to self-perform but we are open to subbing out work if the job requires.

GRSC, Inc. has an FDOT Certified MOT supervisor on staff along with a certified SWPPP inspector.



1643 NW Dove Court
Stuart, FL 34994
(772) 888-6818
gaynam@grscinc.net

Professional Qualifications of Individual Staff

Gaynam Rackstraw - President

- State of Florida Certified General Contractor
- Over 20 years' experience in construction and construction management.
- Director of Construction for Pulte Homes SWFL prior to forming GRSC, Inc. in 2012.
- Extensive experience in project management, land development, and construction operations management
- Actively involved in the field while managing HR, Sales, and Accounting for GRSC, Inc.
- BS, Food and Resource Economics – University of Florida
- MBA – University of Florida

Tony Vinson - Vice president of Construction

- Manages all field operations for GRSC, Inc.
- More than 30 years of construction experience including all aspects of site development.
- His management experience includes site development, park construction, golf course construction, drainage construction and improvement projects, and all aspects of horizontal construction.
- Experienced in managing both private and public construction projects

Brad Searcy - Operations Manager

- 8 years of construction experience
- Worked as construction superintendent and purchasing agent for Pulte Homes SWFL
- 15 years' Operations/Procurement experience in the produce industry
- Manages the bid process for public and private construction jobs.
- Manages compliance and billing for public jobs.
- BS, Food and Resource Economics – University of Florida
- Master of Agribusiness – University of Florida



GRSC, INC.

1643 NW Dove Court
Stuart, FL 34994
(772) 888-6818
gaynam@grscinc.net

Caleb Weaver – Project Foreman

- 20 years' experience in construction including private and public site construction.
- Coordinates the efforts of multiple crews on the jobsite.
- Working foreman who is also a machine operator.
- Certified as a State of Florida SWPPP Inspector.

Christian Mendoza – MOT Manager

- FDOT MOT Certified
- Designs MOT plans for GRSC, Inc. for public and private projects

Ron DeSantis, Governor

Melanie S. Griffin, Secretary



STATE OF FLORIDA
DEPARTMENT OF BUSINESS AND PROFESSIONAL REGULATION
CONSTRUCTION INDUSTRY LICENSING BOARD

THE GENERAL CONTRACTOR HEREIN IS CERTIFIED UNDER THE
PROVISIONS OF CHAPTER 489, FLORIDA STATUTES

RACKSTRAW, GAYNAM BERRY

GRSC, INC.
1643 NW DOVE CT
STUART FL 34994

LICENSE NUMBER: CGC1521089

EXPIRATION DATE: AUGUST 31, 2026

Always verify licenses online at MyFloridaLicense.com



ISSUED: 06/12/2024

Do not alter this document in any form.

This is your license. It is unlawful for anyone other than the licensee to use this document.

CERTIFICATE OF COMPLETION



Christian Mendoza

Has Completed a FDOT Approved Temporary Traffic Control (TTC): Advanced Course

Training Provider:

US Safety Alliance

www.USsafetyAlliance.com

Doral FL 33122

Phone: 904-705-5660

Verify this Certificate by visiting www.motadmin.com

08/15/2024

Issue Date

08/09/2028

Expiration Date

RM

Instructor

629081

Certificate No.

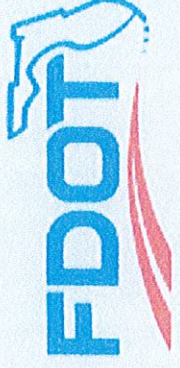



GRSC, INC.

1643 NW Dove Court
Stuart, FL 34994
(772) 888-6818
gaynam@grscinc.net

Bonding and Financial Capacity

- See attached bonding capacity letter from Cecil W. Powell & Company confirming capacity of \$10,000,000.00 / \$20,000,000.00 aggregate.
- GRSC, Inc. does not have current audited financials. Typically, we pursue public projects valued at less than \$3,000,000.00. Our bond underwriter does not require audited financial for this work. Please find attached P&L Statement for the previous 2 quarters. We are willing to provide additional information if required.



Knowledge and Wisdom[®]

CECIL W. POWELL & COMPANY

INSURANCE, INTERNATIONAL FINANCIAL PLANNING AND SURETY BONDS SINCE 1935
219 N. NEWNAN STREET • P.O. DRAWER 41490, JACKSONVILLE, FLORIDA 32203-1490
PHONE (904) 353-3181 • FAX (904) 353-5722 • www.cwpowellins.com

April 14, 2026

GRSC, Inc.
1643 NW Dove Court
Stuart, FL 34994

RE: Town of Indian River Shores
Beachcomber Lane and Pebble Lane Roadway and Sewer Project

To Whom It May Concern:

Cecil W. Powell & Company is the bonding agent for **GRSC, Inc.** Based on normal and standard underwriting criteria at the time of the request, Performance and Payment bonds will be provided on for projects up to \$10,000,000 with a \$20,000,000 aggregate with the provision that we and *Old Republic Surety Company* reserve the right to review final contractual documents, bond forms, and obtain satisfactory evidence of funding prior to any final commitment to issue bonds, and do not assume liability to any third party, including yourselves, if we do not execute said bonds. *Old Republic Surety Company* is "A" rated by A.M. Best.

GRSC, Inc. is an excellent contractor, and we hold them in the highest regard. We feel extremely confident in our contractor and encourage you to offer them an opportunity to execute any upcoming projects.
If you should have any questions, please do not hesitate to give me a call. Sincerely,

A handwritten signature in blue ink that reads "Ben Powell".

Benjamin K. Powell
Senior Vice President



Profit and Loss
GRSC Inc
October 1, 2025-March 31, 2026

	Total
Income	\$5,088,425.01
Cost of Goods Sold	\$1,941,536.53
Gross Profit	\$3,146,888.48
Expenses	\$2,207,406.48
Net Operating Income	\$939,482.00
Other Expenses	\$6.00
Net Other Income	-\$6.00
Net Income	\$939,476.00



*Project Approach
Schedule*

1643 NW Dove Court
Stuart, FL 34994
(772) 888-6818
gaynam@grscinc.net

Project Approach and Schedule

Our construction sequence for the project would be dependent on meeting with the Town Building Official and Utilities Department. We can accommodate the needs of the Town, Utilities Department and residents. Our initial planned sequence would start as follows:

Mobilize and implement SWPPP and MOT plan on Beachcomber Lane

Open cut asphalt and install sewer main and connections. Work would be confined to one lane only so that a lane always remains open for traffic. Traffic control devices will be in use and always maintained as required. Work will proceed so that all excavation will be backfilled with rock at the end of each workday.

Once the sewer main is complete we will move to the opposite lane and use the same procedure to connect and complete the sewer services.

Drainage structures will be installed concurrently with the sewer.

When the pipe crew completes work on Beachcomber they will move directly to the Pebble and begin work in the same sequence as Beachcomber.

Our Asphalt crew will follow directly behind the pipe crew and begin milling existing asphalt. Work will be confined to one lane at a time to allow access to residents.

We would then install a first lift of asphalt, one lane at a time. Traffic control devices and methods would be utilized as required at all times. After first lift our asphalt crew will be available to begin work on Pebble Lane as soon as the sewer work is complete.

Following the first lift on Beachcomber, our concrete crew would mobilize to install the curb and driveway aprons. Every attempt will be made to allow residents access to their driveways at this time. Residents who have a single driveway may lose access for a short time at this stage.

Our goal would be to complete all sod, mailboxes, and any irrigation repairs and landscape replacements at this time. Once that is complete, we would put down final lift on Beachcomber and Pebble.

Striping would follow final lift.



1643 NW Dove Court
Stuart, FL 34994
(772) 888-6818
gaynam@grscinc.net

We would have our surveyor make multiple trips to the site to pick up as-built information during construction to expedite final as-builts.

Maintenance of Traffic Approach

All MOT plans will be designed in accordance with FDOT standards. Plans will be submitted to the EOR for review prior to implementation. On this job our plan would include the use of signage, barrels, cones, and flagmen when required. We would always confine work to one lane to maintain street access to residents.

Staffing and Equipment resources

GRSC, Inc. employees are primarily residents of Martin, St. Lucie, and Indian River County. We have personnel and equipment in use at multiple locations in Indian River County. Depending on the existing work schedule we are typically able to mobilize our personnel and equipment to Indian River County within 2 days.

Staffing for this job would include:

Project manager x 1 – On site regularly and available by phone at all times

Project Foreman x 1 – On site during all work hours

Operator x 2 – On site during work hours as needed

General Labor x 2/3 – On site during work hours as needed

Asphalt Crew: Crew Leader x 1, Labor x 3. On site during milling and asphalt activities

Pipe Crew: Crew Leader x 1, Labor x 3. On site during all underground utility activities

Concrete Crew: Crew Leader x 1, Labor x 4. On site during all concrete activities

Equipment required for this job is company owned. The only anticipated rental is for a trench box to be used during excavation.

GRSC, Inc Equipment

Year	Make	Model	Description
2019	Ford	F250	4x2 Utility Box Bed Crew Cab White
2019	Kubota	KX040-4R1	Excavator
2016	Kubota	SVL75-2	Compact Track Loader
2018	Kubota	KX018-4	Mini Excavator
2006	Pace	Trailer	Single axle enclosed trailer
2020	Big Tex	14LX-14BK7SIRPD	14ft Dump Trailer Tandem Axles
2016	Case	521F	Case 521 front-end wheel loader
2018	Case	650M	Case 650M bull dozer
2019	Dodge	Ram 2500	4x2 Utility Bed Crew Cab White
2015	Case	CX80	Case 80 HP Excavator
2019	Case	CX37C	Case 37 HP Excavator
2017	Laymor	SM300	3 wheeled tractor sweeper
2019	Pronovost	P-516	Tag along dump trailer
2019	Kubota	GST L5060	4WD Tractor
2019	Pronovost	P-516	Tag along dump trailer
2020	Kubota	SVL75-2W	Compact Track Loader
2020	Egger Beaver	15HDB-PT	Trailer 8,100 lbs, can carry 30,000 lbs 38,100 GVWR. 20 ft Heavy Duty Flatbed Deck over
2017	Volvo	VHD64B200	Dump truck
2019	Wacker Neuson	BPU4045A	Reversible Vibratory 24" Plate Honda motor
2014	Pronovost	P-516	Tag along dump trailer
2018	Kubota	M5660SUHD	4WD Tractor
2014	Pronovost	P-516	Tag along dump trailer
2017	Kubota	L4760GST	4WD Tractor
2018	Kubota	L4760GST	4WD Tractor
2020	Kubota	SVL75-2W	Compact Track Loader
2021	Chevrolet	Silverado 3500	4x4 Crew Cab Diesel Flatbed
2021	Takeuchi	TL8R-2	Compact Track Loader
2020	Takeuchi	TB250-2	Mini Excavator
1999	Komatsu	WA180-3L	Wheel Loader
2012	Kenworth	T800	Tri-Axle Dump Truck
2021	Rolls Rite	Rolls Rite 48K	Trailer 8,000 lbs can carry 40,000 lb 48,000 GVWR. Deck over Flatbed trailer
2014	Case	621F	Wheel Loader
2021	Ford	F250	4x4 White long bed
2021	Down to Earth Trailer	7X14 TA 14K	14ft Dump Trailer Tandem Axles
2021	BigFoot Trailers	14ET20XP	14,000 lb 20ft low profile equipment trailer
2022	Kubota	SVL75-2W	75 CTL / 15" RUB TRKS/CNPY/LDR/MECH
2021	Dodge	Ram 2500	4x4 Short Bed Crew Cab White
2022	Kubota	SVL75-2W	75 CTL / 15" RUB TRKS/CNPY/LDR/MECH
2022	BigFoot Trailers	14ET20XP	14,000 lb 20ft low profile equipment trailer
2022	Chevrolet	Silverado 2500	2 WD Single cable utility bed
2022	Chevrolet	Silverado 2500	2 WD Crew Cab long bed
2005	New Holland	TC40DA	Tractor
2022	BigFoot Trailers	14ET20XP	14,000 lb 20ft low profile equipment trailer
2022	Big Tex	14ET-20BK-KR	14,000 lb 20ft low profile equipment trailer
2022	BigFoot Trailers	14ET20XP	14,000 lb 20ft low profile equipment trailer
2022	Dodge	Ram 2500	4x2 Crew Cab Utility Toolbox
2022	BigFoot Trailers	14DO24	14,000 lb 20ft-4ft dovetail Deck over equip trailer
2021	Takeuchi	TL6R	Compact Track Loader
2022	GMC	Sierra 2500	2WD Double Cab SLE Short Bed
2022	Dodge	Ram 2500	4x2 crew Cab long bed
2016	Case	621F	Front-end Wheel Loader with 3.0-3.4 yard bucket
2015	Case	621F	Front-end Wheel Loader with 3.0-3.4 yard bucket
2014	JCB	714	14 Ton Articulating End Dump Off Road Truck
2022	Kubota	KX71-3S4R1	Excavator
2022	Kubota	SVL 65-2W	CTL with 68" bucket
2015	Ford	F650	Truck with 5-6 yard dump bed GVWR 30,000 lbs
2022	Kubota	SVL65-2W	CTL with 68" Heavy duty low profile Land Pride bucket
2022	Kubota	U17VR1	Mini Excavator
2022	Kubota	SVL65-2W	CTL with 68" Heavy duty low profile Land Pride bucket
2022	Chevrolet	Silverado 2500	White 2500 Pickup Truck 4x4 Crew Cab
2022	Kubota	SVL65-2HW	CTL with 68" Heavy duty low profile Land Pride bucket
2016	Hamm	H71	Roller 61-70 VIB Single Drum Smooth
2021	Bobcat	E32I	Mini Excavator
2017	International	4300	Non-CDL dump truck 25,999 lbs
2018	International	4300	Non-CDL dump truck 25,999 lbs
2018	Weller	P385B	Track Asphalt Paver

Year	Make	Model	Description
2023	Kubota	SVL97-2H	97 CTL /17.7" RUBBER TRKS/CANOPY with LAND PRIDE 80" HD Bucket
2021	Case	621G	Front end loader
2023	Case	221F	Front end loader 1.3 yard bucket and 48" forks
2023	BigFoot Trailers	14DO24	14,000 lb equip trailer
2022	Mauldin	MT300	Hot Track Sprayer 300 gal Traller
2023	GPS Trailers	EH2014K	20ft gray equipment trailer with dove tail and fold down ramps GVW 14000, W 2775 Net 11225
2023	Kubota	SVL75-2W	Compact Track Loader with model AP-HD74LLC bucket
2023	Kubota	U17VR1	Mini Excavator
2022	Ram	2500	Single cab 4x4 pick up truck with Cummins diesel
????	Volvo Champlon	720A	Motor Grader
2017	Case	CX145D	Excavator with hydraulic thumb
1994	Ford	F700	Straight dump bed truck
2024	Big Tex	16ET-19+3MR	22ft Traller with mega ramps
2016	Freightliner	CASCADIA 125DC	Road tractor day cab
2017	LEDWELL	LW48HT2-10-PB	Flat bed trailer (trailer weighs 16,700 lbs and its rated at 80,000 lbs it can carry 63,300 lbs)
2021	Hamm	HD14IVV	ROLLER 4-7 TON DOUBLE DRUM SMOOTH
2024	Kubota	SVL75-3W	Compact Track Loader, 15" TRKS/CNPY/MECH QA
2024	Chevrolet	Silverado 2500	short bed gas pickup truck
1981	Ingram	12T-3W	12 Ton Drum Roller
2024	Weller	CT3A	Pneumatic rubber tire roller compactor
2025	Chevrolet	Silverado 2500	short bed gas pickup truck
2025	Kubota	SVL97-2HFC	Compact track loader with closed cab a/c, high flow and 80" bucket
2025	Bradco	HP1000 & 104444	40" cold planer with water & dust suppression kit
2025	Chevrolet	Silverado 2500	Single cab 2WD white 6.6L gas engine



GRSC, INC.

1643 NW Dove Court
Stuart, FL 34994
(772) 888-6818
gaynam@grscinc.net

Quality Control Process

Daily quality control is coordinated by the Project Manager and Project Foreman through daily inspection and construction reports. They will work closely with the Town Building Official and Utilities Department to ensure that all required testing is complete as required. SWPPP and MOT inspections are completed as required and deficiencies are corrected immediately.

Submittals, shop drawings, and mix designs are submitted by the Operations Manager for review and approval.

Milestone Timeline

See attached Gantt chart

Project Name: Beachcomber Lane and Pebble Lane Roadway and Sewer Project
 Project Number: 11B 24-01
 Location: The Town of Indian River Shores

Construction Schedule - week beginning:

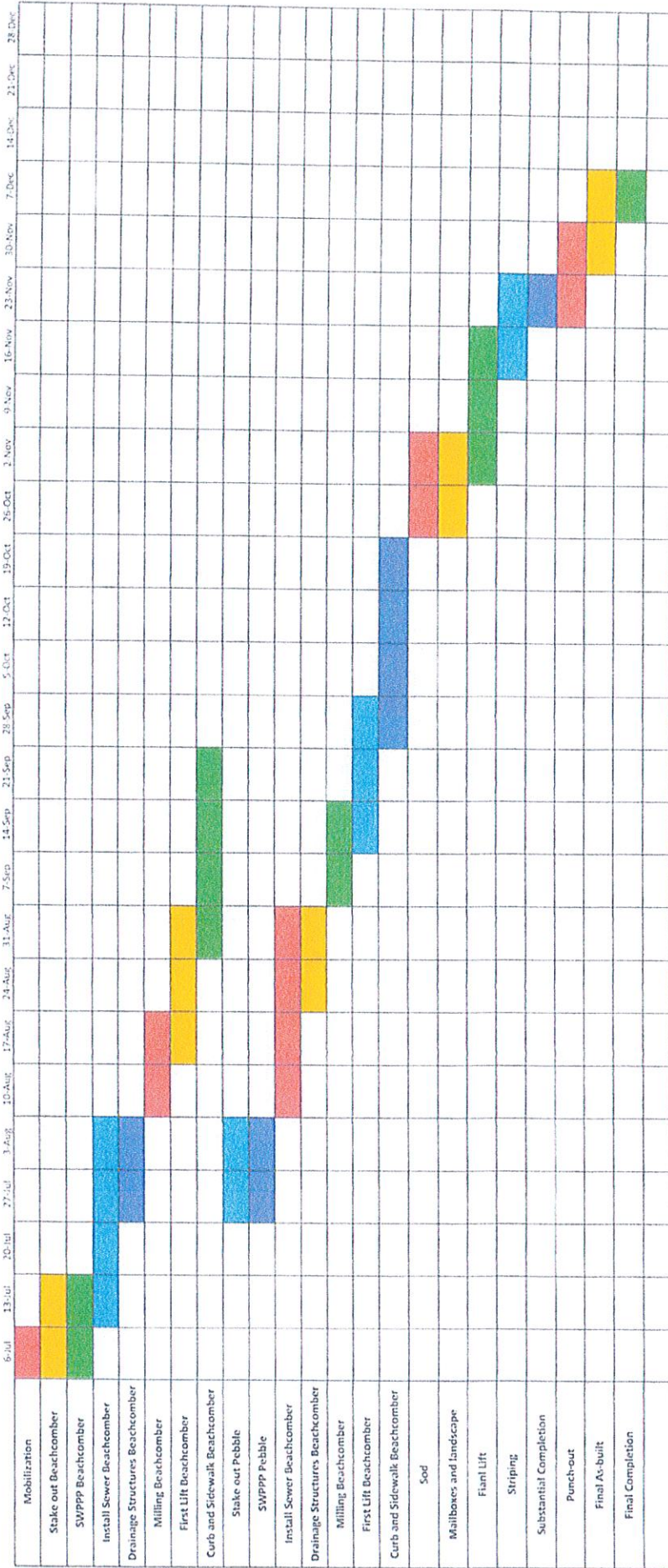

Revision Date: 4/14/2026
 Revised by: Brad Swartz

The Town of Indian River Shores, Florida

ITB 26-01

Beachcomber Lane and Pebble Lane
Roadway and Sewer Project

Total Sum Sheet

TOTAL \$ 1,945,338.67

Please utilize the attached bid sheet.

*Bid Pricing
Form*

**SECTION 00300
BID FORM**

Town Council
Town of Indian River Shores
6001 Highway A1A
Indian River Shores, FL 32963

GRSC, Inc.
(BIDDER'S COMPANY NAME)

I have received the documents titled Pebble Lane Roadway Improvements and Beachcomber Lane Roadway Improvements. I have also received addendum number 1 through 3 and have included their provisions in my bid. I have examined both the bid documents and the construction site and submit the following bid in which I agree:

1. To hold my bid open until an agreement has been executed between the Town of Indian River Shores and accepted Bidder, including receipt of the Public Construction and Maintenance Bonds, or until **100** days after bids are opened, whichever is longer.
2. Regarding the Disposition of Bid Security: to accept the provisions of the Instructions to the Bidders.
3. To enter into and execute a Contract on the basis of this bid and to furnish a 100% Public Construction Bond in accordance with the Instructions to Bidders to guarantee my workmanship and materials to be free from construction defects for a period of not less than one (1) year, if this bid is accepted.
4. To accomplish the work included in, and in accordance with the Contract Documents, if this bid is accepted.
5. To start work within ten (10) calendar days from the date of the Notice to Proceed and thereafter to substantial work completion of the Pebble Lane Roadway Improvements and Beachcomber Lane Roadway Improvements within **180** calendar days. Final work completion within **30** calendar days following substantial work completion, unless the time is modified by provisions of the contract, if this bid is accepted.
6. Regarding Compensation for the proposed work: if this bid is accepted, I will construct this project on a unit price basis as reflected in the Bid Unit Price Schedule on pages **300-2 through 300-6** of this bid.
7. Regarding the Award of the Contract: if I am awarded a contract for this project, I understand that the award may be for all or any portion thereof of the items listed under the Bid Unit Price Schedule.

Town of Indian River Shores
Public Works Department

BID UNIT PRICE SCHEDULE
Pebble Lane Roadway Improvements

ITEM NO.	DESCRIPTION	UNIT MEASURE	EST. QUAN.	UNIT PRICE	AMOUNT
101-1A	MOBILIZATION / DEMOBILIZATION	LS	1	\$66,500.00	\$66,500.00
102-1A	MAINTNENANCE OF TRAFFIC	LS	1	\$32,640.00	\$32,640.00
104-2A	PREVENTION, CONTROL, & ABATEMENT OF EROSION & WATER POLLUTION	LS	1	\$23,392.00	\$23,392.00
108-1A	CONSTRUCTION LAYOUT/ RECORD DRAWING	LS	1	\$24,480.00	\$24,480.00
110-1-1A	STANDARD CLEARING AND GRUBBING	AC	0.60	\$48,000.00	\$28,800.00
110-7-2A	MAILBOX (REMOVE, PROTECT & RESET)	EA	8	\$480.00	\$3,840.00
120-1A	REGULAR EXCAVATION	CY	145	\$12.50	\$1,812.50
120-6A	EMBANKMENT	CY	0	\$18.50	\$0
160-4A	TYPE B STABILIZATION	SY	2076	\$9.25	\$19,203.00
285-7-06A	OPTIONAL BASE GROUP 6 (8" COQUINA)	SY	2076	\$29.35	\$60,930.60
334-1-13A	SUPERPAVE ASPHALTIC CONCRETE (TYPE SP-9.5) (TRAFFIC C) (2")	TN	198	\$179.50	\$35,541.00
425-1-711A	INLET-DRAINAGE (VALLEY GUTTER W/ P-BOTTOM)	EA	2	\$13,050.00	\$26,100.00
430-175-124A	PIPE CULVERT (OPTIONAL MATERIAL) (ROUND) (24")	LF	28	\$228.50	\$6,398.00
520-2-10A	HEADER CURB - CONCRETE	LF	418	\$47.85	\$20,001.30
520-3A	VALLEY GUTTER - CONCRETE	LF	1010	\$37.00	\$37,370.00
522-21A	DRIVEWAY APRON CONCRETE (6" THICK W/ FIBER MESH) (3,000 PSI MIN.)	SY	107	\$130.55	\$13,968.85
522-22A	DRIVEWAY GRAVEL w/ CONCRETE BAND	SY	175	\$136.00	\$23,800.00
SUBTOTAL FROM PAGE 00300-2					\$424,777.25

Town of Indian River Shores
Public Works Department

ITEM NO.	DESCRIPTION	UNIT MEASURE	EST. QUAN.	UNIT PRICE	AMOUNT
522-24A	DRIVEWAY APRON w/ BRICK PAVER (REMOVE & RESET)	SY	77	\$174.10	\$13,405.70
570-1-2A	PERFORMANCE TURF SOD (FLORATAM)	SY	1601	\$8.75	\$14,008.75
999-01A	UTILITY COORDINATION	LS	1	\$5,400.00	\$5,400.00
1050-31-206A	UTILITY PIPE (F&I) (PVC) (6")	LF	523	\$185.00	\$96,755.00
1050-31-208A	UTILITY PIPE (F&I) (PVC) (8")	LF	601	\$195.80	\$117,675.80
1060-11-211A	UTILITY MANHOLE (SAN. SEWER) (F&I) (<80CF) (<6' DEPTH)	EA	4	\$9,975.00	\$39,900.00
1060-11-222A	UTILITY MANHOLE (SAN. SEWER) (F&I) (>80CF) (6.1' - 12' DEPTH)	EA	1	\$16,265.00	\$16,265.00
1080-15A	WATER METER / SERVICE (ADJUST)	EA	2	\$950.00	\$1,900.00
700-1-500A	SINGLE POST SIGN (RELOCATE)	EA	1	\$650.00	\$650.00
711-11-125A	THERMOPLASTIC TRAFFIC STRIPING (WHITE) (24")	LF	10	\$10.80	\$108.00
711-11-221A	THERMOPLASTIC TRAFFIC STRIPING (YELLOW) (6")	LF	100	\$9.75	\$975.00
SUBTOTAL THIS PAGE (00300-3)					\$307,043.25
SUBTOTAL FROM PAGE 00300-2					\$424,777.25
ESTIMATED BASE BID AMOUNT (Based on Bid Unit Prices & Estimated Quantities, a summation of Pages 00300-2 to 00300-3)					\$731,820.50
999-99	CONSTRUCTION CONTINGENCY ALLOWANCE (10 Percent of Base Bid)				\$73,182.05
TOTAL PEBBLE LANE ESTIMATED AMOUNT (Based on Bid Unit Prices, Estimated Quantities, & 10 Percent Contingency)					\$805,002.55

Town of Indian River Shores
Public Works Department

BID UNIT PRICE SCHEDULE
Beachcomber Lane Roadway Improvements

ITEM NO.	DESCRIPTION	UNIT MEASURE	EST. QUAN.	UNIT PRICE	AMOUNT
101-1B	MOBILIZATION / DEMOBILIZATION	LS	1	\$75,000.00	\$75,000.00
102-1B	MAINTNENANCE OF TRAFFIC	LS	1	\$32,640.00	\$32,640.00
104-2B	PREVENTION, CONTROL, & ABATEMENT OF EROSION & WATER POLLUTION	LS	1	\$23,392.00	\$23,392.00
108-1B	CONSTRUCTION LAYOUT/ RECORD DRAWING	LS	1	\$21,500.00	\$21,500.00
110-1-1B	STANDARD CLEARING AND GRUBBING	AC	0.40	\$48,000.00	\$19,200.00
110-7-2B	MAILBOX (REMOVE, PROTECT & RESET)	EA	15	\$489.60	\$7,344.00
120-1B	REGULAR EXCAVATION	CY	43	\$12.50	\$537.50
120-6B	EMBANKMENT	CY	3	\$18.50	\$55.50
160-4B	TYPE B STABILIZATION	SY	2945	\$9.25	\$27,241.25
285-7-06B	OPTIONAL BASE GROUP 6 (8" COQUINA)	SY	2945	\$29.35	\$86,435.75
327-70-5B	MILLING EXISTING ASPHALT PAVEMENT (2" AVG DEPTH)	SY	370	\$4.35	\$1,609.5
334-1-13B	SUPERPAVE ASPHALTIC CONCRETE (TYPE SP-9.5) (TRAFFIC C) (2")	TN	275	\$179.50	\$49,362.50
425-1-711B	INLET-DRAINAGE (VALLEY GUTTER W/ P-BOTTOM)	EA	4	\$13,050.00	\$52,200.00
425-5B	MANHOLE (ADJUST)	EA	1	\$2,720.00	\$2,720.00
425-6B	VALVE / METER (ADJUST)	EA	2	\$950	\$1,900.00
430-175-118B	PIPE CULVERT (CONCRETE) (ROUND) (18")	LF	218	\$201.25	\$43,872.50
443-70-3B	EXFILTRATION TRENCH, 18" RCP	LF	184	\$228.50	\$42,044.00
SUBTOTAL FROM PAGE 00300-4					\$487,054.50

Town of Indian River Shores
Public Works Department

ITEM NO.	DESCRIPTION	UNIT MEASURE	EST. QUAN.	UNIT PRICE	AMOUNT
520-3B	VALLEY GUTTER - CONCRETE	LF	2006	\$37.00	\$74,222.00
522-1B	CONCRETE SIDEWALK AND DRIVEWAYS (4" THICK)	SY	9	\$92.50	\$832.50
522-21B	DRIVEWAY APRON CONCRETE (6" THICK W/ FIBER MESH) (3,000 PSI MIN.)	SY	164	\$130.50	\$21,402.00
522-22B	DRIVEWAY GRAVEL w/ CONCRETE BAND	SY	71	\$136.00	\$9,656.00
522-24B	DRIVEWAY APRON w/ BRICK PAVER (REMOVE & RESET)	SY	54	\$174.10	\$9,401.40
570-1-2B	PERFORMANCE TURF SOD (FLORATAM)	SY	873	\$8.75	\$7,638.75
999-01B	UTILITY COORDINATION	LS	1	\$5,440.00	\$5,440.00
1050-31-206B	UTILITY PIPE (F&I) (PVC) (6")	LF	768	\$185.00	\$142,080.00
1050-31-208B	UTILITY PIPE (F&I) (PVC) (8")	LF	1009	\$195.80	\$197,562.20
1060-11-221B	UTILITY MANHOLE (SAN. SEWER) (F&I) (>80CF) (0-6' DEPTH)	EA	5	\$14,680.00	\$73,400.00
1080-15B	WATER METER / SERVICE (ADJUST)	EA	2	\$950.00	\$1,900.00
711-11-123B	THERMOPLASTIC TRAFFIC STRIPING (WHITE) (12")	LF	177	\$9.75	\$1,725.75
711-11-125B	THERMOPLASTIC TRAFFIC STRIPING (WHITE) (24")	LF	202	\$10.80	\$2,181.60
711-11-160B	PAVEMENT MESSAGE (THERMOPLASTIC) (WHITE)	EA	1	\$545.00	\$545.00
711-11-170B	DIRECTIONAL ARROWS (THERMOPLASTIC) (WHITE)	EA	3	\$217.50	\$652.50
711-11-221B	THERMOPLASTIC TRAFFIC STRIPING (YELLOW) (6")	LF	100	\$9.75	\$975.00
SUBTOTAL THIS PAGE (00300-5)					\$549,614.70
SUBTOTAL FROM PAGE 00300-4					\$487,054.50
ESTIMATED BASE BID AMOUNT (Based on Bid Unit Prices & Estimated Quantities, a summation of Pages 00300-4 to 00300-5)					\$1,036,669.20
999-99	CONSTRUCTION CONTINGENCY ALLOWANCE (10 Percent of Base Bid)				\$103,666.92

Town of Indian River Shores
Public Works Department

TOTAL BEACHCOMBER LANE ESTIMATED AMOUNT (Based on Bid Unit Prices, Estimated Quantities, & 10 Percent Contingency)	\$1,140,336.12
--	----------------

Contractor shall coordinate any type of traffic restrictions with the Town of Indian River Shores Public Works Department. The contractor shall notify the Town of Indian River Shores Public Works Department of any road restrictions at least two (2) weeks prior to actual implementation.

NOTE: This bid is on a unit price basis. The total estimated amount is for bid comparison purposes only. The contractor should field verify the actual site conditions prior to time of bidding and before submitting the bid proposal. The contractor should read the special conditions and the requirements for insurance before submitting a bid proposal. The contractor should verify the quantities to be included in the construction contract. The contractor shall furnish the Town of Indian River Shores with a Public Construction Bond in 100% of the total estimated amount of the contract. The Public Construction Bond shall continue in effect for one (1) year after completion and acceptance of the work as guarantee against construction defects. The contractor in his bid shall include the cost of said bond. Density testing shall be at the expense of the Town of Indian River Shores, except for failing tests, which shall be charged to the contractor.

I have attached the required 5% Bid Security to this Bid.

Date 4/14/2026

Bidder GRSC, Inc

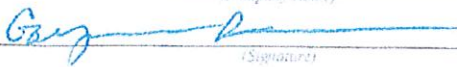
By 

By Gaynam Rackstraw

Title President

Mailing Address 1643 NW Dove Ct

Stuart, FL 34994

Office Number 772-888-6818

Fax Number None

Town of Indian River Shores
Public Works Department

00300 - 6

GOVERNING SPECIFICATIONS:

The governing specifications for this project are the State of Florida Department of Transportation Standard Specifications for Road and Bridge Construction (Dated 2024), the FDOT FY 2024-25 Design Standards and the current City of Vero Beach Utility Department Standards. The following information provided in Section 00300 is in addition to the specifications previously referenced **and shall be considered the governing condition** in the case of conflicting information between specifications, plans, and contract documents, unless otherwise determined by the Engineer.

BID ITEMS:

<p>101-1A 101-1B</p>	<p>Mobilization / Demobilization</p> <p>The bid price for this item shall include, but not be limited to the requirements of Section 101 Mobilization of the Standard Specifications, as well as all operations and preparations necessary to begin and end the work on the project. This shall also include those operations necessary for the movement of personnel, equipment, material and incidentals to the site, establishment of safety equipment, first aid supplies, and sanitary facilities, as required by the Contract Documents. The cost of required bonds and any insurance(s) shall be included in this item. The cost for the Contractor to obtain the services of an Engineer to develop the Stormwater Pollution and Prevention Plan (SWPPP) in order to apply for the National Pollution Discharge Elimination System (NPDES) permit shall also be included in this line item. This item will also include any costs to obtain a South Florida Water Management District (SFWMD) Dewatering permit, if necessary.</p> <p>At the pre-construction meeting, the CONTRACTOR shall submit a tentative work schedule (inclusive of overall project phasing plan) as well as a list of subcontractors and emergency contact people and phone numbers. In addition, the CONTRACTOR shall perform and submit a copy of a video archive of existing conditions prior to construction activity commencement. The format of the existing conditions video archive shall be coordinated with the COUNTY prior to collection.</p> <p>Any and all work performed within the drip line of trees designated to remain shall be accomplished with the assistance and supervision of a certified arborist. Any costs related to obtaining a certified arborist shall be included in this bid item.</p> <p>At the pre-construction meeting, the CONTRACTOR shall submit a tentative work schedule as well as a list of subcontractors and emergency contact people and phone numbers.</p> <p>The basis of payment for Mobilization / Demobilization shall be paid as LUMP SUM.</p>
<p>102-1A 102-1B</p>	<p>Maintenance of Traffic</p> <p>The bid price for this item shall include, but not be limited to, the requirements of Section 102 Maintenance of Traffic of the Standard Specifications. The maintenance of traffic for this project shall be in accordance with the applicable FDOT index numbers (600 Series) and these documents: The Manual on Uniform Traffic Control Devices for Streets and Highways, U.S. Department of Transportation, and FHWA. These documents shall be followed in the design, application, installation, maintenance and removal of the Maintenance of Traffic. It shall include, but not be limited to all traffic control devices, warning devices, barriers, temporary reflective markers, temporary pavement markings, dust control and all items necessary to protect the public and</p>

Town of Indian River Shores
Public Works Department

	<p>workmen from hazards within the project limits. Temporary pavement markings that follow the final design shall be painted markings in accordance with the specifications. The temporary markings shall be applied to the driving surface if the driving surface is left unattended overnight. The temporary markings include those markings provided between asphalt lifts and after the final asphalt lift during the 30-day cure period. All costs for temporary markings shall be included in the Maintenance of Traffic pay item. No roadway travel lanes, intersection or other existing paved thoroughfare shall be left unpaved for more than 48 hours, or during inclement weather. The cost for temporary pavement, as necessary to comply with this requirement, is included in the Maintenance of Traffic pay item</p> <p>At the Pre-Construction Meeting the CONTRACTOR shall submit a detailed plan of how the existing traffic will be maintained through the work site during the construction period along with the traffic control to be utilized for approval by the ENGINEER. The following items shall apply:</p> <ul style="list-style-type: none">• The CONTRACTOR shall coordinate any type of traffic restrictions with the City of Vero Beach Water Quality Division.• The CONTRACTOR shall notify the Town of Indian River Shores Public Works Department of any road closures at least two (2) weeks prior to actual implementation.• The CONTRACTOR shall provide access to driveways at all times.• The CONTRACTOR shall allow access for all emergency and postal delivery vehicles and school buses. <p>The basis of payment for Maintenance of Traffic shall be paid as LUMP SUM.</p>
<p>104-2A 104-2B</p>	<p>Prevention, Control & Abatement of Erosion & Water Pollution</p> <p>The CONTRACTOR shall be required to provide Turbidity and Pollution Control Devices in accordance with all State, Local, and Federal Standards, Section 104 Prevention, Control, and Abatements of Erosion and Water Pollution of the Standard Specifications, and applicable FDOT Roadway and Traffic Design Standards for this project. The methods shall include but are not limited to the following options: hay bales, silt fences, soil tracking prevention devices and/or turbidity barriers. The existing drainage of the site must be maintained at all times.</p> <p>The CONTRACTOR shall maintain all earthwork construction throughout the life of the contract, and shall take all reasonable precautions to prevent loss of material from the construction site due to the action of wind or water. The CONTRACTOR shall repair at their expense, except otherwise provided herein, any slides, washouts, settlements, subsidence, or other mishap, which may occur prior to final acceptance of the work. Maintenance and protection of earthwork construction shall be in accordance with Section 104 of the Standard specifications.</p> <p>The CONTRACTOR shall submit a sketch or detailed written description of the proposed turbidity and pollution control to be used and how the existing drainage will be maintained at the Pre-Construction meeting, for approval by the Engineer. The CONTRACTOR shall</p>

	<p>submit all field records for this item. Final payment is based on acquisition of the complete field book/records.</p> <p>The basis of payment for Prevention, Control & Abatement of Erosion & Water Pollution shall be paid as LUMP SUM.</p>
<p>108-1A 108-1B</p>	<p>Construction Layout / Record Drawing</p> <p>The bid price shall include, but not be limited to: all material and labor associated with the preparation of record drawings and construction layout as specified in the plans. Six (6) hard copy sets of As-Built Record (11"x17") drawings signed and sealed by a Licensed Surveyor registered in the state of Florida and one (1) electronic copy shall be submitted in both .PDF format and .DWG format with all as-built information provided.</p> <p>CONTRACTOR shall also provide accurate as-built dimensions and elevations of the roadside swales immediately after final grading and prior to sodding of the slopes. At a minimum, the CONTRACTOR shall provide cross sections on all sides of the right-of-way shown on the design plans. Information shall include elevations at center of road, edge of travel lane, edge of shoulder, top of bank, toe of slope, ties to existing elevations, and limits of armoring (if any). In addition, all drainage structure and pipe sizes, inverts, rim elevations, top elevations, grate elevations, locations, openings, connections, and all other features in the as-built survey and plans. If any modifications are specified, additional as-builts may be required. The CONTRACTOR shall accurately record the location and elevations of the improvements, existing utilities, adjusted utilities, and structures encountered during construction.</p> <p>The basis of payment for Construction Layout / Record Drawing shall be paid as LUMP SUM.</p>
<p>110-1-1A 110-1-1B</p>	<p>Standard Clearing and Grubbing</p> <p>The bid price for this item shall include, but not be limited to, the requirements of Section 110 Clearing and Grubbing of the Standard Specifications. The bid price shall include, but not be limited to: clearing and grubbing required for the roadway right-of-way and for lateral ditches, detention areas, channel changes, or other outfall areas, and any other select clearing and grubbing indicated, or required for the construction of the entire project, including all necessary hauling, furnishing equipment, equipment operation, furnishing any areas required for disposal of debris, leveling of terrain, and the landscaping work of trimming, except for any areas designated to be paid for separately or to be specifically included in the costs of other work under the Contract.</p> <p>Includes removal and legal disposal of steel posts, asphalt pavement, base, trees and shrubs, culverts and storm structures, concrete areas not indicated to remain and all other items in order to construct the project. This will also include the removal of any existing posts, fences, and gates. Any existing posts, fences, or gates shall be turned into the homeowner in the same condition that it was found.</p> <p>Native vegetation's that are not in the areas of the proposed construction parameters are to remain undisturbed. Clearing and Grubbing over a Gas Main shall extend no greater than 20-Feet along gas pipeline at any time. The Gas Company shall be notified 72 hours prior to Clearing and Grubbing activities and on-site, observing the work during the process.</p>

	<p>Any and all work performed within the drip line of trees not designated for removal shall be accomplished with the on-site assistance and supervision of a certified arborist.</p> <p>The basis of payment for Standard Clearing and Grubbing shall be paid as ACRE.</p>
<p>110-7-2A 110-7-2B</p>	<p>Mailbox (Remove, Protect & Reset)</p> <p>The bid price for this item shall include, but not be limited to, the requirements of Section 110 Clearing and Grubbing of the Standard Specifications. The unit cost shall include, but not be limited to the required manpower, equipment, materials, and any other items necessary as described within the plans.</p> <p>The basis of payment for Mailbox (Remove, Protect & Reset) shall be paid as EACH.</p>
<p>120-1A 120-1B</p>	<p>Regular Excavation</p> <p>The bid price for this item shall include, but not be limited to, the requirements of Section 120 Excavation and Embankment of the Standard Specifications. The unit cost shall include, but not be limited to the required manpower, equipment, materials, and any other items necessary as described within the plans.</p> <p>The basis of payment for Regular Excavation shall be paid as CUBIC YARD.</p>
<p>120-6A 120-6B</p>	<p>Embankment</p> <p>The bid price for this item shall include, but not be limited to, the requirements of Section 120 Excavation and Embankment of the Standard Specifications. The unit cost shall include, but not be limited to the required manpower, equipment, materials, and any other items necessary as described within the plans.</p> <p>The basis of payment for Embankment shall be paid as CUBIC YARD.</p>
<p>160-4A 160-4-B</p>	<p>Type B Stabilization</p> <p>The bid price for this item shall include, but not be limited to, the requirements of Section 160 Stabilizing of the Standard Specifications. The unit cost shall include, but not be limited to the required manpower, equipment, materials, and any other items necessary as described within the plans.</p> <p>The basis of payment for Type B Stabilization shall be paid as SQUARE YARD.</p>
<p>285-7-06A 285-7-06B</p>	<p>Optional Base Group 6 (8" Coquina)</p> <p>The bid price for this item shall include, but not be limited to, the requirements of Section 285 Optional Base Course of the Standard Specifications. The unit cost shall include, but not be limited to the required manpower, equipment, materials, and any other items necessary as described within the plans.</p> <p>The basis of payment for Optional Base Group 6 (8" Coquina) shall be paid as SQUARE YARD.</p>

327-70-5B	<p>Milling Existing Asphalt Pavement (2" Avg Depth)</p> <p>The bid price for this item shall include, but not limited to, the requirements of Section 327 Milling of Existing Asphalt Pavement of the Standard Specifications. The unit cost shall include, but not be limited to the required manpower, equipment, materials, and any other items necessary as described within the plans.</p> <p>The basis of payment for Milling Existing Asphalt Pavement (2" Avg Depth) shall be paid as SQUARE YARD.</p>
334-1-13A 334-1-13B	<p>Superpave Asphaltic Concrete (Type SP-9.5) (Traffic C) (2")</p> <p>The bid price for this item shall include, but not limited to, the requirements of Section 334 Superpave Asphalt Concrete of the Standard Specifications. The unit cost shall include, but not be limited to the required manpower, equipment, materials, and any other items necessary as described within the plans.</p> <p>The basis of payment for Superpave Asphaltic Concrete (Type SP-9.5) (Traffic C) (2") shall be paid as TON.</p>
425-1-711A 425-1-711B	<p>Inlet-Drainage (Valley Gutter W/ P-Bottom)</p> <p>The bid price for this item shall include, but not be limited to, the requirements of Sections 425 Inlets, Manholes, and Junction Boxes of the Standard Specifications. The unit cost shall include, but not be limited to the required manpower, equipment, dewatering materials and any other items necessary as described within the plans.</p> <p>The area of excavation shall be maintained in a dry condition, at all times, by the use of an adequate dewatering system if necessary.</p> <p>The soil beneath all inlets, regardless if left undisturbed, shall be compacted to a density not less than 95 percent of the maximum density as determined by AASHTO T-180 for a minimum depth of two (2) foot below the bottom of the excavation. Rock wrapped in filter fabric shall not be used as bedding material without written approval by the ENGINEER/OWNER'S PROJECT MANAGER.</p> <p>At the Pre-Construction Meeting the CONTRACTOR shall be required to submit shop drawings for approval by the ENGINEER.</p> <p>The basis of payment for Inlet-Drainage (Valley Gutter W/ P-Bottom) shall be paid as EACH.</p>
425-5B	<p>Manhole (Adjust)</p> <p>The bid price for this item shall include, but not limited to, the requirements of Section 425 Inlets, Manholes, and Junction Boxes of the Standard Specifications. The unit cost shall include, but not be limited to the required manpower, equipment, materials, and any other items necessary as described within the plans.</p> <p>The basis of payment for Manhole (Adjust) shall be paid as EACH.</p>

Town of Indian River Shores
Public Works Department

425-6B	<p>Valve / Meter (Adjust)</p> <p>The bid price for this item shall include, but not limited to, the requirements of Section 425 Inlets, Manholes, and Junction Boxes of the Standard Specifications. The unit cost shall include, but not be limited to the required manpower, equipment, materials, and any other items necessary as described within the plans.</p> <p>The basis of payment for Valve / Meter (Adjust) shall be paid as EACH.</p>
430-175-118B	<p>Pipe Culvert (Concrete) (Round) (18")</p> <p>The bid price for this item shall include, but not be limited to, the requirements of Section 430 Pipe Culverts of the Standard Specifications. The unit cost shall include, but not be limited to all excavation except volume included in items for the grading work on the project, and except for other items specified for separate payment in Section 125; all backfilling material and compaction; disposal of surplus material; dewatering; and all clearing and grubbing outside of the required limits of clearing and grubbing as described in the plans.</p> <p>All pipe to drainage structure connections shall be wrapped with filter fabric per FDOT Standard Index No. 201. All pipe joints shall be overlapped with filter fabric per FDOT Index No. 280 in addition to the Manufacture's gasket recommendations. Cost is to be included in this bid item.</p> <p>The basis of payment for Pipe Culvert (Optional Material) (Round) (18") shall be paid as LINEAR FEET.</p>
430-175-124A	<p>Pipe Culvert (Optional Material) (Round) (24")</p> <p>The bid price for this item shall include, but not be limited to, the requirements of Section 430 Pipe Culverts of the Standard Specifications. The unit cost shall include, but not be limited to all excavation except volume included in items for the grading work on the project, and except for other items specified for separate payment in Section 125; all backfilling material and compaction; disposal of surplus material; dewatering; and all clearing and grubbing outside of the required limits of clearing and grubbing as described in the plans.</p> <p>All pipe to drainage structure connections shall be wrapped with filter fabric per FDOT Standard Index No. 201. All pipe joints shall be overlapped with filter fabric per FDOT Index No. 280 in addition to the Manufacture's gasket recommendations. Cost is to be included in this bid item.</p> <p>The basis of payment for Pipe Culvert (Optional Material) (Round) (24") shall be paid as LINEAR FEET.</p>
443-70-3B	<p>Exfiltration Trench, 18" RCP</p> <p>The bid price for this item shall include, but not be limited to, the requirements of Section 443 French Drains of the Standard Specifications. The unit cost shall include, but not be limited to all excavation except volume included in items for the grading work on the project, and except for other items specified for separate payment in Section 125; all backfilling material and</p>

	<p>compaction; disposal of surplus material; dewatering; and all clearing and grubbing outside of the required limits of clearing and grubbing as described in the plans.</p> <p>The basis of payment for Exfiltration Trench, 18" RCP shall be paid as LINEAR FEET.</p>
<p>520-2-10A</p>	<p>Header Curb - Concrete</p> <p>The bid price for this item shall include, but not limited to, the requirements of Section 520 Concrete Gutter, Curb Elements, and Traffic Separator of the Standard Specifications. The unit cost shall include all materials, manpower and equipment for installation as shown on the plans.</p> <p>The basis of payment for Header Curb - Concrete shall be paid as LINEAR FEET.</p>
<p>520-3A 520-3B</p>	<p>Valley Gutter - Concrete</p> <p>The bid price for this item shall include, but not limited to, the requirements of Section 520 Concrete Gutter, Curb Elements, and Traffic Separator of the Standard Specifications. The unit cost shall include all materials, manpower and equipment for installation as shown on the plans.</p> <p>The basis of payment for Valley Gutter - Concrete shall be paid as LINEAR FEET.</p>
<p>522-1B</p>	<p>Concrete Sidewalk and Driveways (4" Thick)</p> <p>The bid price for this item shall include, but not be limited to, the requirements of Section 522 Concrete Sidewalks and Driveways of the Standard Specifications and Index 522-001 of the FDOT FY 2024-2025 Design Standards. The unit cost shall include all materials, manpower and equipment for installation as shown on the plans.</p> <p>The basis of payment for Concrete Sidewalk and Driveways (4" Thick) shall be paid as SQUARE YARD.</p>
<p>522-21A 522-21B</p>	<p>Driveway Apron Concrete (6" Thick w/ Fiber Mesh) (3,000 PSI Min.)</p> <p>The bid price for this item shall include, but not be limited to, the requirements of Section 522 Concrete Sidewalks and Driveways of the Standard Specifications and Index 522-003 of the FDOT FY 2024-2025 Design Standards. The unit cost shall include all materials, manpower and equipment for installation as shown on the plans.</p> <p>Locations of driveways are approximate and shall be field adjusted to suit the actual requirements at the time of construction.</p> <p>Concrete mix shall contain synthetic (polypropylene) fibers in the amount of one and one half (1.5) pounds per cubic yard.</p> <p>No concrete shall be poured until a Town of Indian River Shores inspector approves the formwork.</p> <p>One week prior to pouring concrete the CONTRACTOR shall be required to submit the mix designs for approval by the ENGINEER.</p>

Town of Indian River Shores
Public Works Department

	<p>The basis of payment for Driveway Apron Concrete (6" Thick w/ Fiber Mesh) (3,000 PSI Min.) shall be paid as SQUARE YARD.</p>
<p>522-22A 522-22B</p>	<p>Driveway Gravel w/ Concrete Band</p> <p>The bid price for this item shall include, but not be limited to, the requirements of Section 522 Concrete Sidewalks and Driveways of the Standard Specifications and Index 522-003 of the FDOT FY 2024-2025 Design Standards. The unit cost shall include all materials, manpower and equipment for installation as shown on the plans.</p> <p>Locations of driveways are approximate and shall be field adjusted to suit the actual requirements at the time of construction.</p> <p>Concrete mix shall contain synthetic (polypropylene) fibers in the amount of one and one half (1.5) pounds per cubic yard.</p> <p>No concrete shall be poured until a Town of Indian River Shores inspector approves the formwork.</p> <p>One week prior to pouring concrete the CONTRACTOR shall be required to submit the mix designs for approval by the ENGINEER.</p> <p>The basis of payment for Driveway Gravel w/ Concrete Band shall be paid as SQUARE YARD.</p>
<p>522-24A 522-24B</p>	<p>Driveway Apron w/ Brick Paver (Remove & Reset)</p> <p>The bid price for this item shall include, but not be limited to, the requirements of Section 522 Concrete Sidewalks and Driveways of the Standard Specifications and Index 522-003 of the FDOT FY 2024-2025 Design Standards. The unit cost shall include all materials, manpower and equipment for installation as shown on the plans.</p> <p>Locations of driveways are approximate and shall be field adjusted to suit the actual requirements at the time of construction.</p> <p>The basis of payment for Driveway Apron w/ Brick Paver (Remove & Reset) shall be paid as SQUARE YARD.</p>
<p>570-1-2A 570-1-2B</p>	<p>Performance Turf Sod (Floritam)</p> <p>The bid price for this item shall include, but not be limited to the requirements of Section 570 Performance Turf of the Supplemental Standard Specifications as well as all manpower, equipment, materials, and any other items necessary to perform the task. All disturbed areas shall be covered to match like kind. Also included in this item is any fertilizer and water needed. All disturbed areas shall be covered with a good stand of grass upon acceptance of the project by the Town of Indian River Shores Town Council. The CONTRACTOR will be responsible for repairing all washed-out and eroded areas and watering of the sod until such time as the project is accepted by the Town of Indian River Shores Town Council.</p> <p>The basis of payment for Performance Turf Sod (Floritam) shall be paid as SQUARE YARD.</p>

Town of Indian River Shores
Public Works Department

<p>999-01A 999-01B</p>	<p>Utility Coordination</p> <p>The Contractor shall coordinate with all local utility companies as necessary to complete construction and any necessary utility adjustments required to install all components. The contractor shall call Sunshine Notification Center at 1-800-432-4770 two business days before digging. The contractor shall notify utility companies two business days before digging to allow them to observe work. This item shall also include all labor and materials necessary to adjust, relocate and/or hold any utilities required to accommodate the proposed improvements and not paid for itemized elsewhere.</p> <p>The basis of payment for Utility Coordination shall be paid as a LUMP SUM.</p>
<p>1050-31-206A 1050-31-206B</p>	<p>Utility Pipe (F&I) (PVC) (6")</p> <p>The bid price for this item shall meet the requirements of the City of Vero Beach Utility Standards, latest edition. The unit cost shall include, but not be limited to all excavation except volume included in items for the grading work on the project, all backfilling material and compaction; furnishing of all tools, materials, machines, pipe flushing (pigging), dewatering and equipment for installation as shown on the plans.</p> <p>The basis of payment for Utility Pipe (F&I) (PVC) (6") shall be paid as LINEAR FEET.</p>
<p>1050-31-208A 1050-31-208B</p>	<p>Utility Pipe (F&I) (PVC) (8")</p> <p>The bid price for this item shall meet the requirements of the City of Vero Beach Utility Standards, latest edition. The unit cost shall include, but not be limited to all excavation except volume included in items for the grading work on the project, all backfilling material and compaction; furnishing of all tools, materials, machines, pipe flushing (pigging), dewatering and equipment for installation as shown on the plans. In addition, unit cost to include installation of mechanical joint restraints pursuant to the City of Vero Beach Utility Standards.</p> <p>The basis of payment for Utility Pipe (F&I) (PVC) (8") shall be paid as LINEAR FEET.</p>
<p>1060-11-211A</p>	<p>Utility Manhole (San. Sewer) (F&I) (<80CF) (<6' Depth)</p> <p>The bid price for this item shall meet the requirements of the City of Vero Beach Utility Standards, latest edition. The unit cost shall include, but not be limited to all excavation except volume included in items for the grading work on the project, all backfilling material and compaction; dewatering; furnishing of all tools, materials, machines, and equipment for installation as shown on the plans.</p> <p>The basis of payment for Utility Manhole (San. Sewer) (F&I) (<80CF) (<6' Depth) shall be paid as EACH.</p>
<p>1060-11-221B</p>	<p>Utility Manhole (San. Sewer) (F&I) (>80CF) (0-6' Depth)</p> <p>The bid price for this item shall meet the requirements of the City of Vero Beach Utility Standards, latest edition. The unit cost shall include, but not be limited to all excavation except volume included in items for the grading work on the project, all backfilling material and compaction;</p>

Town of Indian River Shores
Public Works Department

	<p>dewatering; furnishing of all tools, materials, machines, and equipment for installation as shown on the plans.</p> <p>The basis of payment for Utility Manhole (San. Sewer) (F&I) (>80CF) (0-6' Depth) shall be paid as EACH.</p>
1060-11-222A	<p>Utility Manhole (San. Sewer) (F&I) (>80CF) (6.1' – 12' Depth)</p> <p>The bid price for this item shall meet the requirements of the City of Vero Beach Utility Standards, latest edition. The unit cost shall include, but not be limited to all excavation except volume included in items for the grading work on the project, all backfilling material and compaction; dewatering; furnishing of all tools, materials, machines, and equipment for installation as shown on the plans.</p> <p>The basis of payment for Utility Manhole (San. Sewer) (F&I) (>80CF) (6.1' – 12' Depth) shall be paid as EACH.</p>
1080-15A 1080-15B	<p>Water Meter / Service (Adjust)</p> <p>The bid price for this item shall meet the requirements of the City of Vero Beach Utility Standards, latest edition. The unit cost shall include, but not be limited to all excavation except volume included in items for the grading work on the project, all backfilling material and compaction; furnishing of all tools, materials, machines, and equipment for installation as shown on the plans.</p> <p>The basis of payment for Water Meter / Service (Adjust) shall be paid as EACH.</p>
700-1-500A	<p>Single Post Sign (Relocate)</p> <p>The bid price for this item shall meet the requirements of Section 700 Highway Signing of the Standard Specifications. The unit cost shall include all cleaning and preparing of surfaces, furnishing of all materials, application, curing and protection of traffic, furnishing of all tools, machines and equipment for installation as shown on the plans.</p> <p>The basis of payment for Single Post Sign (Relocate) shall be paid as EACH.</p>
711-11-123B	<p>Thermoplastic Traffic Striping (White) (12")</p> <p>The bid price for this item shall meet the requirements of Section 711 Thermoplastic Pavement Markings of the Standard Specifications. The unit cost shall include all cleaning and preparing of surfaces, furnishing of all materials, application, curing and protection of traffic, furnishing of all tools, machines and equipment for installation as shown on the plans.</p> <p>The basis of payment for Thermoplastic Traffic Striping (White) (12") shall be paid as LINEAR FEET.</p>
711-11-125A 711-11-125B	<p>Thermoplastic Traffic Striping (White) (24")</p> <p>The bid price for this item shall meet the requirements of Section 711 Thermoplastic Pavement Markings of the Standard Specifications. The unit cost shall include all cleaning and preparing of</p>

Town of Indian River Shores
Public Works Department

	<p>surfaces, furnishing of all materials, application, curing and protection of traffic, furnishing of all tools, machines and equipment for installation as shown on the plans.</p> <p>The basis of payment for Thermoplastic Traffic Striping (White) (24") shall be paid as LINEAR FEET.</p>
711-11-160B	<p>Pavement Message (Thermoplastic) (White)</p> <p>The bid price for this item shall meet the requirements of Section 711 Thermoplastic Pavement Markings of the Standard Specifications. The unit cost shall include all cleaning and preparing of surfaces, furnishing of all materials, application, curing and protection of traffic, furnishing of all tools, machines and equipment for installation as shown on the plans.</p> <p>The basis of payment for Pavement Message (Thermoplastic) (White) shall be paid as EACH.</p>
711-11-170B	<p>Directional Arrows (Thermoplastic) (White)</p> <p>The bid price for this item shall meet the requirements of Section 711 Thermoplastic Pavement Markings of the Standard Specifications. The unit cost shall include all cleaning and preparing of surfaces, furnishing of all materials, application, curing and protection of traffic, furnishing of all tools, machines and equipment for installation as shown on the plans.</p> <p>The basis of payment for Directional Arrows (Thermoplastic) (White) shall be paid as EACH.</p>
711-11-221A 711-11-221B	<p>Thermoplastic Traffic Striping (Yellow) (6")</p> <p>The bid price for this item shall meet the requirements of Section 711 Thermoplastic Pavement Markings of the Standard Specifications. The unit cost shall include all cleaning and preparing of surfaces, furnishing of all materials, application, curing and protection of traffic, furnishing of all tools, machines and equipment for installation as shown on the plans.</p> <p>The basis of payment for Thermoplastic Traffic Striping (Yellow) (6") shall be paid as LINEAR FEET.</p>

THE AMERICAN INSTITUTE OF ARCHITECTS



AIA Document A310

Bid Bond

KNOW ALL MEN BY THESE PRESENTS, that GRSC, Inc. as Principal, hereinafter called the Principal, and Old Republic Surety Company a corporation duly organized under the laws of the State of FL as Surety, hereinafter called the Surety, are held and bound unto Town of Indian River Shores as Obligee, hereinafter called the Obligee, in the sum of

Five Percent of Bid Amount Dollars (\$ 5%)

for the payment of which sum well and truly to be made, the said Principal and the said Surety, bind ourselves, our heirs, executors, administrators, successors and assigns, jointly and severally, firmly by these presents.

WHEREAS, the Principal has submitted a bid for

Town of Indian River Shores ITB 26-01
Beachcomber Lane and Pebble Lane Roadway and Sewer Project

NOW, THEREFORE, if the Obligee shall accept the bid of the Principal and the Principal shall enter into a Contract with the Obligee in accordance with the terms of such bid, and give such bond or bonds as may be specified in the bidding or Contract Documents with good and sufficient surety for the faithful performance of such Contract and for the prompt payment of labor and material furnished in the prosecution thereof, or in the event of the failure of the Principal to enter such Contract and give such bond or bonds, if the Principal shall pay to the Obligee the difference not to exceed the penalty hereof between the amount specified in said bid and such larger amount for which the Obligee may in good faith contract with another party to perform the Work covered by said bid, then this obligation shall be null and void, otherwise to remain in full force and effect.

Signed and Sealed this 14th day of April 2026



(Witness)



(Witness)

GRSC, Inc. 

(Principal) (Seal)

President

(Title)

Old Republic Surety Company

(Surety) (Seal)



Benjamin K. Powell, Attorney in Fact



POWER OF ATTORNEY

KNOW ALL MEN BY THESE PRESENTS: That OLD REPUBLIC SURETY COMPANY, a Wisconsin stock insurance corporation, does make, constitute and appoint FITZHUGH K. POWELL, JR, ROBERT T. THEUS, BENJAMIN K. POWELL of JACKSONVILLE, FL

its true and lawful Attorney(s)-in-Fact, with full power and authority for and on behalf of the company as surety, to execute and deliver and affix the seal of the company thereto (if a seal is required), bonds, undertakings, recognizances or other written obligations in the nature thereof, (other than bail bonds, bank depository bonds, mortgage deficiency bonds, mortgage guaranty bonds, guarantees of installment paper and note guaranty bonds, self-insurance workers compensation bonds guaranteeing payment of benefits, or black lung bonds), as follows:

ALL WRITTEN INSTRUMENTS

and to bind OLD REPUBLIC SURETY COMPANY thereby, and all of the acts of said Attorneys-in-Fact, pursuant to these presents, are ratified and confirmed. This appointment is made under and by authority of the board of directors at a special meeting held on February 18, 1982.

This Power of Attorney is signed and sealed by facsimile under and by the authority of the following resolutions adopted by the board of directors of the OLD REPUBLIC SURETY COMPANY on February 18, 1982.

RESOLVED that, the president, any vice-president or assistant vice president, in conjunction with the secretary or any assistant secretary, may appoint attorneys-in-fact or agents with authority as defined or limited in the instrument evidencing the appointment in each case, for and on behalf of the company to execute and deliver and affix the seal of the company to bonds, undertakings, recognizances, and suretyship obligations of all kinds; and said officers may remove any such attorney-in-fact or agent and revoke any Power of Attorney previously granted to such person.

RESOLVED FURTHER, that any bond, undertaking, recognizance, or suretyship obligation shall be valid and binding upon the Company

- (i) when signed by the president, any vice president or assistant vice president, and attested and sealed (if a seal be required) by any secretary or assistant secretary; or
(ii) when signed by the president, any vice president or assistant vice president, secretary or assistant secretary, and countersigned and sealed (if a seal be required) by a duly authorized attorney-in-fact or agent; or
(iii) when duly executed and sealed (if a seal be required) by one or more attorneys-in-fact or agents pursuant to and within the limits of the authority evidenced by the Power of Attorney issued by the company to such person or persons.

RESOLVED FURTHER that the signature of any authorized officer and the seal of the company may be affixed by facsimile to any Power of Attorney or certification thereof authorizing the execution and delivery of any bond, undertaking, recognizance, or other suretyship obligations of the company; and such signature and seal when so used shall have the same force and effect as though manually affixed.

IN WITNESS WHEREOF, OLD REPUBLIC SURETY COMPANY has caused these presents to be signed by its proper officer, and its corporate seal to be affixed this 15th day of January 2025

Karen J. Hafner
Assistant Secretary



OLD REPUBLIC SURETY COMPANY

Alan Pavlic
President

STATE OF WISCONSIN, COUNTY OF WAUKESHA - SS

On this 15th day of January 2025, personally came before me, Alan Pavlic and Karen J Hafner, to me known to be the individuals and officers of the OLD REPUBLIC SURETY COMPANY who executed the above instrument, and they each acknowledged the execution of the same, and being by me duly sworn, did severally depose and say: that they are the said officers of the corporation aforesaid, and that the seal affixed to the above instrument is the seal of the corporation, and that said corporate seal and their signatures as such officers were duly affixed and subscribed to the said instrument by the authority of the board of directors of said corporation.



Kathryn R. Pearson
Notary Public

My Commission Expires: September 28, 2026

(Expiration of notary's commission does not invalidate this instrument)

CERTIFICATE

I, the undersigned, assistant secretary of the OLD REPUBLIC SURETY COMPANY, a Wisconsin corporation, CERTIFY that the foregoing and attached Power of Attorney remains in full force and has not been revoked; and furthermore, that the Resolutions of the board of directors set forth in the Power of Attorney, are now in force.

92-2350



Signed and sealed at the City of Brookfield, WI this 14th day of April 2026

Karen J. Hafner
Assistant Secretary

ORSC 22252 (3-05)

CECIL W. POWELL & CO.

BID UNDERSTANDING

The undersigned acknowledges having reviewed the entire ITB, including all instructions, conditions, specifications, and attachments, and agrees to furnish all goods and services described at the prices shown on the attached Bid Pricing Form and Total Sum Sheet. The undersigned further understands that failure to examine any portion of the solicitation does not relieve the Bidder of its obligations and does not constitute grounds to seek additional compensation or modify the resulting contract.

GRSC, Inc.	1643 NW Dove Ct
Name of Contractor	Address
	Stuart, FL 34994
Authorized Signature	City, State, Zip Code
President	772-888-6818
Title	Phone
4/13/2026	gaynam@grscinc.net
Date Signed	E-mail

ADDENDUM ACKNOWLEDGEMENT

The Proposer shall acknowledge obtaining all addenda issued to this formal solicitation by completing the blocks below. Failure to acknowledge all addenda may be cause for rejection of the response.

Addendum No: <u> 1 </u> Date Issued <u> 3/16/2026 </u> <u> 3/23/2026 </u>	Addendum No: <u> 2 </u> Date Issued _____
Addendum No: <u> 3 </u> Date Issued <u> 4/7/2026 </u> _____	Addendum No: _____ Date Issued _____
Addendum No: _____ Date Issued _____	Addendum No: _____ Date Issued _____

Required Forms

QUALIFICATIONS QUESTIONNAIRE

NOTICE: THE TOWN RETAINS THE DISCRETION TO REJECT THE BIDS OF NON-RESPONSIBLE BIDDERS.

Documentation Submitted with Project No: ITB 26-01

Project Name: Beachcomber Lane and Pebble Lane Roadway and Sewer Project

1. Bidder's Name / Address: GRSC, Inc.
1643 NW Dove Ct., Stuart, FL 34994
2. Bidder's Telephone & FAX Numbers: Phone - (772) 473-2201
Fax - none
3. Licensing and Corporate Status:
 - a. Is Contractor License current? Yes
 - b. Bidder's Contractor License No: CGC1521089
[Attach a copy of Contractor's License to the bid]
 - c. Attach documentation from the State of Florida Division of Corporations that indicates the business entity's status is active and that lists the names and titles of all officers.
4. Number of years the firm has performed business as a Contractor in construction work of the type involved in this contract: 13
5. What is the last project OF THIS NATURE that the firm has completed?
City of Stuart - Riverside Neighborhood Improvements
6. Has the firm ever failed to complete work awarded to you? No

[If your answer is "yes", then attach a separate page to this questionnaire that explains the circumstances and list the project name, Owner, and the Owner's telephone number for each project in which the firm failed to complete the work.]
7. Has the firm ever been assessed liquidated damages? No

[If your answer is "yes", then attach a separate page to this questionnaire that explains the circumstances and list the project name, Owner, and the Owner's telephone number for each project in which liquidated damages have been assessed.]
8. Has the firm ever been charged by OSHA for violating any OSHA regulations? No

[If your answer is "yes", then attach a separate page to this questionnaire that explains the circumstances and list the project name, Owner, and the Owner's telephone number for each project in which OSHA violations were alleged.]

9. Has the firm implemented a drug-free workplace program in compliance with Florida Statute 287.087? Yes
10. Has the firm ever been charged with noncompliance of any public policy or rules?
No
[If your answer is "yes", then attach a separate page to this questionnaire that explains the circumstances and list the project name, Owner, and the Owner's telephone number for each project.]
11. Attach to this questionnaire, a notarized financial statement and other information that documents the firm's financial strength and history.
12. Has the firm ever defaulted on any of its projects? No

[If your answer is "yes", then attach a separate page to this questionnaire that explains the circumstances and list the project name, Owner, and the Owner's telephone number for each project in which a default occurred.]
13. Attach a separate page to this questionnaire that summarizes the firm's current workload and that demonstrates its ability to meet the project schedule.
14. Name of person who inspected the site of the proposed work for the firm:
Name: Tony Vinson Date of Inspections: 4/6/2026
15. Name of on-site Project Foreman: Tony Vinson
Number of years of experience with similar projects as a Project Foreman: 30
16. Name of Project Manager: Tony Vinson
Number of years of experience with similar projects as a Project Manager: 30
17. State your total bonding capacity: \$20,000,000.00
18. State your bonding capacity per job: \$10,000,000.00
19. Please provide name, address, telephone number, and contact person of your bonding company:
Cecil W. Powell & Company, Inc. 219 N Newnan Street, Jacksonville, FL 32202
Ben Powell - (904-353-5722)



[Department of State](#) / [Division of Corporations](#) / [Search Records](#) / [Search by Entity Name](#) /

Detail by Entity Name

Florida Profit Corporation
GRSC, INC.

Filing Information

Document Number	P12000047744
FEI/EIN Number	45-5344665
Date Filed	05/23/2012
Effective Date	05/21/2012
State	FL
Status	ACTIVE

Principal Address

1643 NW DOVE CT
STUART, FL 34994

Changed: 02/27/2013

Mailing Address

1643 NW DOVE CT
STUART, FL 34994

Changed: 02/27/2013

Registered Agent Name & Address

RACKSTRAW, GAYNAM B
1643 NW DOVE CT
STUART, FL 34994

Address Changed: 02/27/2013

Officer/Director Detail

Name & Address

Title PRES

RACKSTRAW, GAYNAM B
1643 NW DOVE CT
STUART, FL 34994

Title Secretary

Rackstraw, Alexis A
1643 NW Dove Court
Stuart, FL 34994

Annual Reports

Report Year	Filed Date
2024	02/03/2024

2025	01/19/2025
2026	01/08/2026

Document Images

01/08/2026 -- ANNUAL REPORT	View image in PDF format
01/19/2025 -- ANNUAL REPORT	View image in PDF format
02/03/2024 -- ANNUAL REPORT	View image in PDF format
10/17/2023 -- AMENDED ANNUAL REPORT	View image in PDF format
01/23/2023 -- ANNUAL REPORT	View image in PDF format
01/11/2022 -- ANNUAL REPORT	View image in PDF format
02/03/2021 -- ANNUAL REPORT	View image in PDF format
05/04/2020 -- ANNUAL REPORT	View image in PDF format
02/23/2019 -- ANNUAL REPORT	View image in PDF format
01/22/2018 -- ANNUAL REPORT	View image in PDF format
01/26/2017 -- ANNUAL REPORT	View image in PDF format
01/25/2016 -- ANNUAL REPORT	View image in PDF format
01/16/2015 -- ANNUAL REPORT	View image in PDF format
01/28/2014 -- ANNUAL REPORT	View image in PDF format
02/27/2013 -- ANNUAL REPORT	View image in PDF format
05/23/2012 -- Domestic Profit	View image in PDF format

Ron DeSantis, Governor

Melanie S. Griffin, Secretary



STATE OF FLORIDA
DEPARTMENT OF BUSINESS AND PROFESSIONAL REGULATION

CONSTRUCTION INDUSTRY LICENSING BOARD

THE GENERAL CONTRACTOR HEREIN IS CERTIFIED UNDER THE
PROVISIONS OF CHAPTER 489, FLORIDA STATUTES

RACKSTRAW, GAYNAM BERRY

GRSC, INC.
1643 NW DOVE CT
STUART FL 34994

LICENSE NUMBER: CGC1521089

EXPIRATION DATE: AUGUST 31, 2026

Always verify licenses online at MyFloridaLicense.com



ISSUED: 06/12/2024

Do not alter this document in any form.

This is your license. It is unlawful for anyone other than the licensee to use this document.

Profit and Loss
GRSC Inc
October 1, 2025-March 31, 2026

	Total
Income	\$5,088,425.01
Cost of Goods Sold	\$1,941,536.53
Gross Profit	\$3,146,888.48
Expenses	\$2,207,406.48
Net Operating Income	\$939,482.00
Other Expenses	\$6.00
Net Other Income	-\$6.00
Net Income	\$939,476.00

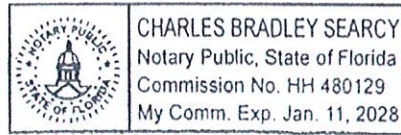

CBS
4/14/2026

20. Complete the following table for SIMILAR projects:

Name of Project	Date Co mpleted	Owner	Contact Person: Name/ Email Address/Phone	Original Contract Amount	Final Contract Amount
Stuart Riverside Neighborhood Improvements	October 2025	City of Stuart/ Martin County	Kathryn Durno 772-288-5777	1,985,996.30	2,167,569.88
Harbor Isles, Vero Beach	2025	Pulte SE Florida	Fabiano Barros 561-722-7926	3,750,000.00	3,750,000.00
Victoria Park site development	2024	KHov Homes	Garfield Hartman 561-577-1149	850,000.00	850,000.00
Pinetree Park/Ternbridge Trail Drainage Improvements	2025	City of Parkland	Richard Biagini 954-757-4171	1,531,347.00	1,538,297.00
Astrotech Warehouse Site Improvements	2025	The W Group	Tom Flynn 772-220-1930	536,000.00	536,000.00

LIST OF SUBCONTRACTORS

The Bidder **MUST** list below the name and address of each Subcontractor who will perform work under this Contract in excess of one-half percent of the total bid price and shall also list the portion of the work which will be done by such Subcontractor. After the opening of Bids, additions, changes or substitutions will not be allowed unless approved by the Town after a request for such a change has been submitted in writing by the Contractor, which shall include reasons for such request. Please attach additional sheets if required.

	Work to be Performed	Subcontractor's Name/Address	Portion of Work (%)
1	Survey	MM&T, Inc. 1655 27th Street Suite 2 Vero Beach, FL 32960	3%
2	Sod	S&J United Sod, LLC. 310 NW 5th Street Okeechobee, FL 34972	1%
3			
4			
5			
6			
7			
8			
9			
10			
11			
12			
13			

PUBLIC RECORDS FORM

ITB Number: ITB 26-01

Project Description: Beachcomber Lane and Pebble Lane Roadway and Sewer Project

In performing services pursuant to this Contract, Contractor shall comply with all relevant provisions of Chapter 119, Florida Statutes. As required by Section 119.0701, Florida Statutes, Contractor shall:

1. Keep and maintain public records required by the Town to perform the service.
2. Upon request from the Town's custodian of public records, provide the Town with a copy the requested records or allow the records to be inspected or copied within a reasonable time at a cost that does not exceed the cost provided in Chapter 119, Florida Statutes, or as otherwise provided by law.
3. Ensure that public records that are exempt or confidential and exempt from public records disclosure requirements are not disclosed except as authorized by law for the duration of the Contract term and following completion of the Contract, if the Contractor does not transfer the records to the Town.
4. Upon completion of the Contract, transfer, at no cost to the Town, all public records in possession of Contractor or keep and maintain public records required by the Town to perform the services. If Contractor transfers all public records to the Town upon completion of the Contract, Contractor shall destroy any duplicate public records that are exempt or confidential and exempt from public records disclosure requirements. If Contractor keeps and maintains public records upon completion of the Contract, Contractor shall meet all applicable requirements for retaining public records. All records stored electronically must be provided to the Town, upon request from the Town's custodian of public records, in a format that is compatible with the information technology systems of the Town.

IN WITNESS WHEREOF, Town and Contractor hereto have made and executed this Contract as of the day and year first above written.

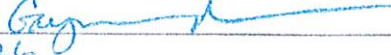
Authorized Signature: 
Date: 4/13/2026

Print Name: Gaynam Rackstraw
Title: President

Company/Firm: GRSC, Inc.

Town reserves the right to accept or reject any or all bids in whole or in part and waive all any technicality or irregularity.

DRUG-FREE WORKPLACE FORM

ITB Number: ITB 26-01

Project Description: Beachcomber Lane and Pebble Lane Roadway and Sewer Project

The undersigned Contractor, in accordance with Florida Statute 287.087, hereby certifies that

GRSC, Inc. does:

1. Publish a statement notifying employees that unlawful manufacture, distribution, dispensing, possession, or use of a controlled substance is prohibited in the workplace and specifying the actions that will be taken against employees for violations of such prohibition.
2. Inform employees about the dangers of drug abuse in the workplace, the business' policy of maintaining a drug free workplace, any available drug counseling, rehabilitation, employee assistance programs and the penalties that may be imposed upon employees for drug abuse violations.
3. Give each employee engaged in providing the commodities or contractual services that are under bid a copy of the statement specified in Paragraph 1.
4. In the statement specified in Paragraph 1, notify the employees that, as a condition of working on the commodities or contractual services that the employee will abide by the terms of the statement and will notify the employer of any conviction of, or plea of guilty or nolo contendere to any violation of Chapter 1893 or of any controlled substance law of the United States or any state, for a violation occurring in the workplace no later than five (5) days after such conviction.
5. Impose a sanction on or require satisfactory participation in a drug abuse assistance or rehabilitation program if such is available in the employee's community, by any employee who is so convicted.
6. Make a good faith effort to continue to maintain a drug free workplace through implementation of Paragraph 1 through 5.

As the person authorized to sign this statement, I certify that this firm complies fully with the above requirement.



Signature

4/13/2026

Date

PUBLIC ENTITY CRIMES FORM

Any person submitting a quote, bid, or bid in response to this invitation or Agreement must execute the enclosed form sworn statement under Section 287.133(3)(a), FLORIDA STATUTES, ON PUBLIC ENTITY CRIMES, including proper check(s), in the space(s) provided, and enclose it with his/her quote, bid, or bid. If you are submitting a quote, bid or bid on behalf of dealers or suppliers who will ship commodities and receive payment from the resulting Agreement, it is your responsibility to see that copy(ies) of the form are executed by them and are included with your quote, bid, or bid. Corrections to the form will not be allowed after the quote, bid, or bid opening time and date. Failure to complete this form in every detail and submit it with your quote, bid, or bid may result in immediate disqualification of your bid or bid.

The 1989 Florida Legislature passed Senate Bill 458 creating Sections 287.132 - 133, Florida Statutes, effective July 1, 1989. Section 287.132(3)(d), Florida Statutes, requires the Florida Department of General Services to maintain and make available to other political entities a "convicted vendor" list consisting of persons and affiliates who are disqualified from public and purchasing process because they have been found guilty of a public entity crime. A public entity crime is described by Section 287.133, Florida Statutes, as a violation of any State or Federal law by a person with respect to and directly related to the transaction of business with any public entity in Florida or with an agency or political subdivision of any other state or with the United States, including, but not limited to, any bid or Agreement for goods or services to be provided to any public entity or with an agency or political subdivision and involving antitrust, fraud, theft, bribery, collusion, racketeering, conspiracy, or material misrepresentation.

By law no public entity shall accept any bid from, award any Agreement to, or transact any business in excess of the threshold amount provided in Section 287.017, Florida Statutes, for Category Two (currently \$35,000) with any person or affiliate on the convicted vendor list for a period of 36 months from the date that person or affiliate was placed on the convicted vendor list, unless that person or affiliate has been removed from the list pursuant to Section 287.133(3)(f), Florida Statutes.

Therefore, effective October 1, 1990, prior to entering into an Agreement (formal Agreement or purchase order) in excess of the threshold amount of \$35,000 to provide goods or services to THE TOWN OF INDIAN RIVER SHORES, a person shall file a sworn statement with the Contract/Agreement officer or Purchasing Director, as applicable. The attached statement or affidavit will be the form to be utilized and must be properly signed in the presence of a notary public or other officer authorized to administer oaths, and properly executed.

THE INCLUSION OF THE SWORN STATEMENT OR AFFIDAVIT SHALL BE SUBMITTED CONCURRENTLY WITH YOUR QUOTE OR BID DOCUMENTS. NON-INCLUSION OF THIS DOCUMENT MAY NECESSITATE REJECTION OF YOUR QUOTE OR BID. SWORN STATEMENT UNDER SECTION 287.133(3)(a), FLORIDA STATUTES, ON PUBLIC ENTITY CRIMES

THIS FORM MUST BE SIGNED IN THE PRESENCE OF A NOTARY PUBLIC OR OTHER OFFICER AUTHORIZED TO ADMINISTER OATH.

This sworn statement is submitted with ITB 26-01 for THE TOWN OF INDIAN RIVER SHORES.

This sworn statement is submitted by GRSC, Inc.

_____ (name of entity submitting sworn statement)
whose business address is

1643 NW Dove CT
Stuart, FL 34994

and its Federal Employer Identification (FEIN) is 45-5344665. (If the entity has no FEIN include the Social Security Number of the individual signing this sworn statement.)

My name is Gaynam Rackstraw (please print name of individual signing) and my relationship to the entity named above is President.

I understand that a "public entity crime" as defined in Paragraph 287.133(1)(g), Florida Statutes, means a violation of any state or federal law by a person with respect to and directly related to the transaction of business with any public entity or with an agency or political subdivision of any other state or with the United States, including, but not limited to, any Bid or Agreement for goods or services to be provided to any public entity or an agency or political subdivision of any other state or of the United States and involving antitrust, fraud, theft, bribery, collusion, racketeering, conspiracy, or material misrepresentation.

I understand that "convicted" or "conviction" as defined in Paragraph 287.133(1)(b), Florida Statutes, means a finding of guilt or a conviction of a public entity crime, with or without an adjudication of guilt, in any federal or state trial court of record relating to charges brought by indictment or information after July 1, 1989, as a result of a jury verdict, nonjury trial, or entry of a plea of guilty or nolo contendere.

I understand that an "affiliate" as defined in Paragraph 287.133(1)(a), Florida Statutes, means:

- A predecessor or successor of a person convicted of a public entity crime; or
- An entity under the control of any natural person who is active in the management of the entity and who has been convicted of a public entity crime.
- The term "affiliate" includes those officers, directors, executives, partners, shareholders, employees, members, and agents who are active in the management of an affiliate. The ownership by one person of shares constituting a controlling interest in another person, or a pooling of equipment or income among persons when not for fair market value under an arm's length agreement, shall be a prima facie case that one person controls another person. A person who knowingly enters into a joint venture with a person who has been convicted of a public entity crime in Florida during the preceding 36 months shall be considered an affiliate.

I understand that a "person" as defined in Paragraph 287.133(1)(e), Florida Statutes, means any natural person or entity organized under the laws of any state or of the United States with the legal power to enter into a binding Agreement and which bids or applies to bid on Agreements for the provision of goods or services let by a public entity, or which otherwise transacts or applies to transact business with a public entity. The term "person" includes those officers, directors, executives, partners, shareholders, employees, members, and agents who are active in management of an entity.

Based on information and belief, the statement which I have marked below is true in relation to the entity submitting this sworn statement. (Please indicate which statement applies.)

- Neither the entity submitting this sworn statement, nor any officers, directors,

executives, partners, shareholders, employees, members, or agents who are active in management of the entity, nor any affiliate of the entity have been charged with and convicted of a public entity crime subsequent to July 1, 1989.

The entity submitting this sworn statement, or one or more of the officers, directors, executives, partners, shareholders, employees, members or agents who are active in management of the entity, or an affiliate of the entity has been charged with and convicted of a public entity crime subsequent to July 1, 1989;

AND (Please indicate which additional statement applies.)

There has been a proceeding concerning the conviction before a hearing officer of the State of Florida, Division of Administrative Hearings. The final order entered by the hearing officer did not place the person or affiliate on the convicted vendor list. (Please attach a copy of the final order.)

The person or affiliate was placed on the convicted vendor list. There has been a subsequent proceeding before a hearing officer of the State of Florida, Division of Administrative Hearings. The final order entered by the hearing officer determined that it was in the public interest to remove the person or affiliate from the convicted vendor list. (Please attach a copy of the final order.)

The person or affiliate has not been placed on the convicted vendor list. (Please provide an attachment describing any action taken by or pending with the Department of General Services.)

Gay R
Signature

4/13/2026
Date

Signature

Date

STATE OF FL
COUNTY OF Indian River

The foregoing instrument was acknowledged before me this 13 day of April, 2026
by Gaynon Rackstraw FL As President of GRSC, Inc. a
personally known to me, or has produced _____ as identification and did
(did not) take an oath.

My Commission Expires: Jan. 11, 2028

CB S
(Signature of Notary)

Name: Charles Bradley Searcy

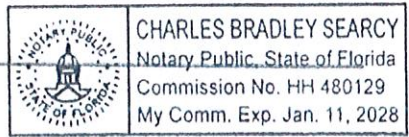

(Legibly Printed)

Notary Public, State of Florida

(AFFIX OFFICIAL SEAL)

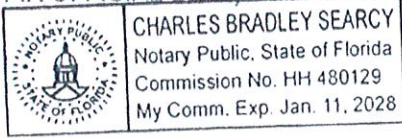

Commission # HH 480129
(if not included on stamped seal)

ITB Number: ITB 26-01

Project Description: Beachcomber Lane and Pebble Lane Roadway and Sewer Project

NON-COLLUSION AFFIDAVIT

ITB Number: ITB 26-01

Project Description: Beachcomber Lane and Pebble Lane Roadway and Sewer Project

Before me, the undersigned authority, personally appeared Gaynam Rackstraw, who, being first duly sworn, deposes and says that he/she is the duly authorized representative of the proposer submitting the attached bid/proposal to the Town of Indian River Shores, Florida, and that such bid/proposal is genuine and not collusive or sham.

That neither the proposer nor any of its officers, partners, owners, agents, representatives, employees, or parties in interest, including this affiant, has in any way colluded, conspired, connived, or agreed, directly or indirectly, with any other proposer or person, to submit a sham bid, or to refrain from bidding, or has in any manner sought by collusion to secure an advantage against the Town of Indian River Shores or any other proposer.

That the proposer has not disclosed any information relating to its bid/proposal to any other firm or competitor, nor has it discussed or agreed upon any terms of its bid/proposal with any other proposer.

That no officer or employee of the Town of Indian River Shores, either individually or collectively, has been directly or indirectly included in the preparation of this proposal or received any compensation, inducement, or reward related to this proposal.

Firm Name: GRSC, Inc.
Authorized Signature: *Gaynam Rackstraw*
Printed Name & Title: Gaynam Rackstraw, President
Date: 4/13/2026

STATE OF FL
COUNTY OF Indian River

The foregoing instrument was acknowledged before me this 13 day of April, 2026 by Gaynam Rackstraw - FL As President of GRSC, Inc. a corporation, on behalf of the corporation. He/she is personally known to me or has produced _____ as identification and did (did not) take an oath.

My Commission Expires: Jan. 11, 2028 *CBS*
(Signature of Notary)

Name: Charles Bradley Searcy
(Legibly Printed)

Notary Public, State of FL

(AFFIX OFFICIAL SEAL)

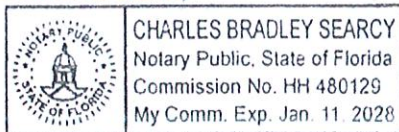

Commission # HH480129
(if not included on stamped seal)

IMMIGRATION AFFIDAVIT CERTIFICATION

ITB Number: ITB 26-01

Project Description: Beachcomber Lane and Pebble Lane Roadway and Sewer Project

This Affidavit is required and should be signed, notarized by an authorized principal of the firm and submitted with formal Invitations to Bid (ITB's) and Request for Bids (RTB) submittals. Further, Consultants / Bidders are required to enroll in the E-Verify program, and provide acceptable evidence of their enrollment, at the time of the submission of the Consultant's/bidder's bid. Acceptable evidence consists of a copy of the properly completed E-Verify Company.

Profile page or a copy of the fully executed E-Verify Memorandum of Understanding for the company. **Failure to include this Affidavit and acceptable evidence of enrollment in the E-Verify program may deem the Consultant / Bidder's bid as non-responsive.**

The Town of Indian River Shores will not intentionally award Town contracts to any Consultant who knowingly employs unauthorized alien workers, constituting a violation of the employment provision contained in 8 U.S.C. Section 1324 a(e) Section 274A(e) of the Immigration and Nationality Act ("INA").

The Town of Indian River Shores may consider the employment by any Consultant of unauthorized aliens a violation of Section 274A (e) of the INA. Such Violation by the recipient of the Employment Provisions contained in Section 274A (e) of the INA shall be grounds for unilateral termination of the contract by the Town of Indian River Shores.

Contractor attests that they are fully compliant with all applicable immigration laws (specifically to the 1986 Immigration Act and subsequent Amendment(s)) and agrees to comply with the provisions of the Memorandum of Understanding with E-Verify and to provide proof of enrollment in The Employment Eligibility Verification System (E-Verify), operated by the Department of Homeland Security in partnership with the Social Security Administration at the time of submission of the Contractor's / Bidder's bid.

Company Name GRSC, Inc.

Print Name Gaynam Rackstraw

Title President

Signature [Handwritten Signature]

Date 4/13/26

STATE OF FL

COUNTY OF Indian River

The foregoing instrument was acknowledged before me this 13 day of April, 2026 by Gaynam Rackstraw As President of GRSC, Inc. a FL corporation, on behalf of the corporation. He/she is personally known to me or has produced _____ as identification and did (did not) take an oath.

My Commission Expires: Jan. 11, 2028

[Handwritten Signature]
(Signature of Notary)

Name: Charles Bradley Searcy
(Legibly Printed)

Notary Public, State of FL

(AFFIX OFFICIAL SEAL)

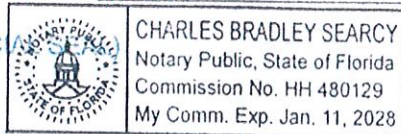

Commission # HH 480129
(if not included on stamped seal)



My Company Account

My Company Profile

Company Information

Company Name

GRSC, Inc.

Doing Business As (DBA) Name

GRSC, Inc.

Company ID

2178353

Enrollment Date

Jun 15, 2023

Employer Identification Number (EIN)

455344665

Unique Entity Identifier (UEI)

DUNS Number

Total Number of Employees

20 to 99

NAICS Code

238

Sector

Construction

Subsector

Specialty Trade Contractors

[Edit Company Information](#)

Employer Category

Employer Category

None of these categories apply

[Edit Employer Category](#)

Company Addresses

Physical Address

1643 NW Dove Court
Stuart, FL 34994

Mailing Address

Same as Physical Address

[Edit Company Addresses](#)

Hiring Sites

Number of Sites

1

[Edit Hiring Sites](#)

Company Access and MOU

My Company is Configured to:

Verify Its Own Employees

Memorandum of Understanding

[View Current MOU](#)

[U.S. Department of Homeland Security](#) [U.S. Citizenship and Immigration Services](#)

[Accessibility](#) [Plug-ins](#) [Site Map](#)



CERTIFICATION REGARDING PROHIBITION AGAINST CONTRACTING WITH SCRUTINIZED COMPANIES

ITB Number: ITB 26-01

Project Description: Beachcomber Lane and Pebble Lane Roadway and Sewer Project

I hereby certify that neither the undersigned entity, nor any of its wholly owned subsidiaries, majority-owned subsidiaries, parent companies, or affiliates of such entities or business associations, that exists for the purpose of making profit have been placed on the Scrutinized Companies that Boycott Israel List created pursuant to s. 215.4725 of the Florida Statutes, or are engaged in a boycott of Israel.

In addition, if this solicitation is for a contract for goods or services of one million dollars or more, I hereby certify that neither the undersigned entity, nor any of its wholly owned subsidiaries, majority-owned subsidiaries, parent companies, or affiliates of such entities or business associations, that exists for the purpose of making profit are on the Scrutinized Companies with Activities in Sudan List or the Scrutinized Companies with Activities in the Iran Petroleum Energy Sector List, created pursuant to s. 215.473 of the Florida Statutes, or are engaged in business operations in Cuba or Syria as defined in said statute.

I understand and agree that the Town may immediately terminate any contract resulting from this solicitation upon written notice if the undersigned entity (or any of those related entities of respondent as defined above by Florida law) are found to have submitted a false certification or any of the following occur with respect to the company or a related entity: (i) it has been placed on the Scrutinized Companies that Boycott Israel List, or is engaged in a boycott of Israel, or (ii) for any contract for goods or services of one million dollars or more, it has been placed on the Scrutinized Companies with Activities in Sudan List or the Scrutinized Companies with Activities in the Iran Petroleum Energy Sector List, or it is found to have been engaged in business operations in Cuba or Syria.

Name of Respondent: GRSC, Inc.

By: 
(Authorized Signature)

Title: President

Date: 4/13/2026

CERTIFICATION REGARDING LOBBYING

Certification for Contracts, Grants, Loans, and Cooperative Agreements

ITB Number: ITB 26-01

Project Description: Beachcomber Lane and Pebble Lane Roadway and Sewer Project

The undersigned Firm certifies, to the best of his or her knowledge, that:

1. No Federal appropriated funds have been paid or will be paid, by or on behalf of the undersigned, to any person for influencing or attempting to influence an officer or employee of an agency, a Member of Congress, an officer or employee of Congress, or an employee of a Member of Congress in connection with the awarding of any Federal contract, the making of any Federal grant, the making of any Federal loan, the entering into of any cooperative agreement, and the extension, continuation, renewal, amendment, or modification of any Federal contract, grant, loan, or cooperative agreement.
2. If any funds other than Federal appropriated funds have been paid or will be paid to any person for influencing or attempting to influence an officer or employee of any agency, a Member of Congress, an officer or employee of Congress, or an employee of a Member of Congress in connection with this Federal contract, grant, loan, or cooperative agreement, the undersigned shall complete and submit Standard Form-LLL, "Disclosure Form to Report Lobbying," in accordance with its instructions.
3. The undersigned shall require that the language of this certification be included in the award documents for all subawards at all tiers (including subcontracts, subgrants, and contracts under grants, loans, and cooperative agreements) and that all subrecipients shall certify and disclose accordingly.

This certification is a material representation of fact upon which reliance was placed when this transaction was made or entered into. Submission of this certification is a prerequisite for making or entering into this transaction imposed by 31, U.S.C. § 1352 (as amended by the Lobbying Disclosure Act of 1995). Any person who fails to file the required certification shall be subject to a civil penalty of not less than \$10,000 and not more than \$100,000 for each such failure.

The Bidder, GRSC, Inc., certifies or affirms the truthfulness and accuracy of each statement of its certification and disclosure, if any. In addition, the Bidder understands and agrees that the provisions of 31 U.S.C. § 3801 et seq., apply to this certification and disclosure, if any.



Signature of Bidder's Authorized Official

Gaynam Rackstraw, President

Name and Title of Bidder's Authorized Official

4/13/2026

Date

CERTIFICATION REGARDING DEBARMENT, SUSPENSION INELIGIBILITY AND VOLUNTARY EXCLUSION

ITB Number: ITB 26-01

Project Description: Beachcomber Lane and Pebble Lane Roadway and Sewer Project

(1) The Bidder certifies that neither it nor its principals is presently debarred, suspended, proposed for debarment, declared ineligible, or voluntarily excluded from participation in this transaction by any Federal department or agency.

(2) Where the prospective lower tier participant is unable to certify any of the statements in this certification, such prospective participant shall attach an explanation to this Bid.



Signature of Bidder's Authorized Official

Gaynam Rackstraw, President

Name and Title of Bidder's Authorized Official

4/13/2026

Date

ANTI-HUMAN TRAFFICKING AFFIDAVIT

The undersigned, on behalf of the entity listed below, in accordance with Florida Statute 787.06(13) hereby attests under penalty of perjury that the entity does not use coercion for labor or services.

As defined in F.S. 787.06(13):

"Coercion" means:

1. Using or threatening to use physical force against any person;
2. Restraining, isolating, or confining or threatening to restrain, isolate, or confine any person without lawful authority and against her or his will;
3. Using lending or other credit methods to establish a debt by any person when labor or services are pledged as a security for the debt, if the value of the labor or services as reasonably assessed is not applied toward the liquidation of the debt, the length and nature of the labor or services are not respectively limited and defined;
4. Destroying, concealing, removing, confiscating, withholding, or possessing any actual or purported passport, visa, or other immigration document, or any other actual or purported government identification document, of any person;
5. Causing or threatening to cause financial harm to any person;
6. Enticing or luring any person by fraud or deceit; or
7. Providing a controlled substance as outlined in Schedule I or Schedule II of s. 893.03 to any person for the purpose of exploitation of that person.

"Labor" means work of economic or financial value.

"Services" means any act committed at the behest of, under the supervision of, or for the benefit of another. The term includes, but is not limited to, forced marriage, servitude, or the removal of organs.

Signature 
Printed Name Gaynam Rackstraw
Title President
Entity Name GRSC, Inc.
Date: 4/13/2026

DISCLOSURE OF RELATIONSHIPS

1. This sworn statement is submitted by (firm name): GRSC, Inc., whose business address is: 1643 NW Dove CT
Stuart, FL 34994.

2. My name is Gaynam Rackstraw, and my relationship to the entity named above is President.

3. I understand that, for purposes of this sworn statement, the term "affiliate" includes officers, directors, executives, partners, shareholders, employees, members, and agents who are active in the management of the entity.

4. I further understand that any relationship with an elected official or employee of the Town of Indian River Shores must be disclosed. For these purposes, "relationship" includes:

Self, father, mother, son, daughter, brother, sister, uncle, aunt, first cousin, nephew, niece, husband, wife, father-in-law, mother-in-law, daughter-in-law, son-in-law, brother-in-law, sister-in-law, stepfather, stepmother, stepson, stepdaughter, stepbrother, stepsister, half-brother, half-sister, grandparent, or grandchild.

5. Based on information and belief, I attest that the statement I have marked below is true in relation to the entity submitting this sworn statement. [Select either a. or b.]

a. Neither the entity submitting this sworn statement, nor any officers, directors, executives, partners, shareholders, employees, members, or agents who are active in management of the entity, have any relationships as defined above with any elected official or employee of the Town of Indian River Shores; or

b. The entity submitting this sworn statement, or one or more of the officers, directors, executives, partners, shareholders, employees, members, or agents who are active in management of the entity, have the following relationships with an elected official or employee of the Town of Indian River Shores:

Name of Affiliate of Entity	Name of Town Elected Official or Employee	Relationship

I hereby swear, under penalty of perjury, the information provided on this form is true.

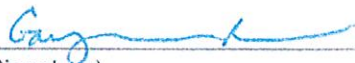
(Signature)

4/13/24
(Date)

SWORN STATEMENT UNDER THE FLORIDA TRENCH SAFETY ACT

THIS FORM MUST BE SIGNED BY THE BIDDER WHO WILL BE RESPONSIBLE FOR THE EXCAVATION WORK ("BIDDER"), OR ITS AUTHORIZED REPRESENTATIVE, IN THE PRESENCE OF A NOTARY PUBLIC AUTHORIZED TO ADMINISTER OATHS.

1. This Sworn Statement is submitted with ITB No. 25-01 for Beachcomber Lane and Pebble Lane Roadway and Sewer Project.
2. This Sworn Statement is submitted by (Legal Name of Entity Submitting Sworn Statement), hereinafter "BIDDER". The BIDDER's address is 1643 NW Dove Ct, Stuart, FL 34994.

BIDDER's Federal Employer Identification Number (FEIN) is 45-5344665.

3. My name is Gaynam Rackstraw and my relationship to the BIDDER is President.

I certify, through my signature at the end of this Sworn Statement, that I am an authorized representative of the BIDDER.

4. The Trench Safety Standards that will be in effect during the construction of this Project are contained within the Trench Safety Act, Section 553.60, Florida Statutes and refer to the applicable Florida Statute(s) and/or OSHA Regulation(s) and include the "effective date" in the citation(s). Reference to and compliance with the applicable Florida Statute(s) and OSHA Regulation(s) is the complete and sole responsibility of the BIDDER. Such reference will not be checked by OWNER or ENGINEER and they shall have no responsibility to review or check the BIDDER's compliance with the Trench Safety Standards.
5. The BIDDER assures the OWNER that it will comply with the applicable Trench Safety Standards.
6. The BIDDER has allocated and included in its bid the total amount of \$ \$20,000.00, based on the linear feet of trench to be excavated over five (5) feet deep, for compliance with the applicable Trench Safety Standards, and intends to comply with said standards by instituting the following specific method(s) of compliance on this Project:
Use of a mobile trench box to access open trench for sewer installation.

The determination of the appropriate method(s) of compliance is the complete and sole responsibility of the BIDDER. Such methods will not be checked by the OWNER or ENGINEER for accuracy, completeness, or any other purpose. The OWNER and ENGINEER shall have no responsibility to review or check the BIDDER's compliance with the Trench Safety Standards.

7. The BIDDER has allocated and included in its bid the total amount of \$ 20,000.00, based on the square feet of shoring to be used for compliance with shoring safety requirements and intends to comply with said shoring requirements by instituting the following specific method(s) of compliance on this Project:
Use of a trench box to support the sides of open trench for sewer installation.

The determination of the appropriate method(s) of compliance is the complete and sole responsibility of the BIDDER. Such methods will not be checked by the OWNER or ENGINEER for accuracy, completeness or any other purpose. The OWNER and ENGINEER shall have no responsibility to review or check the BIDDER's compliance with the Trench Safety Standards.

8. The BIDDER, in submitting this bid, represents that it has obtained and considered all available geotechnical information, has utilized said geotechnical information and that, based on such information and the BIDDER's own information, the BIDDER has sufficient knowledge of the Project's surface and subsurface site conditions and characteristics to assure BIDDER's compliance with the applicable Trench Safety Standards in designing the trench safety system(s) for the Project.

BIDDER: GRSC, Inc.

By: [Signature]

Position of Title: President

Date: 4/13/2026

STATE OF FL

COUNTY OF Indian River

The foregoing instrument was acknowledged before me this 13 day of April, 2026 by Gaynam Rackstrom As President of GRSC, Inc. a FL corporation, on behalf of the corporation. He/she is personally known to me or has produced _____ as identification and did (did not) take an oath.

My Commission Expires: Jan. 11, 2028

[Signature]
(Signature of Notary)

Name: Charles Bradley Searcy
(Legibly Printed)

Notary Public, State of FL

(AFFIX OFFICIAL SEAL)

Commission # HH 480129
(if not included on stamped seal)

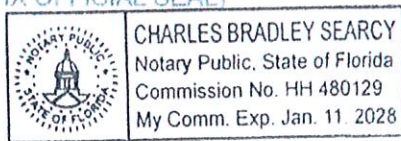



GRSCINC-01

CANHAM1

CERTIFICATE OF LIABILITY INSURANCEDATE (MM/DD/YYYY)
4/13/2026

THIS CERTIFICATE IS ISSUED AS A MATTER OF INFORMATION ONLY AND CONFERS NO RIGHTS UPON THE CERTIFICATE HOLDER. THIS CERTIFICATE DOES NOT AFFIRMATIVELY OR NEGATIVELY AMEND, EXTEND OR ALTER THE COVERAGE AFFORDED BY THE POLICIES BELOW. THIS CERTIFICATE OF INSURANCE DOES NOT CONSTITUTE A CONTRACT BETWEEN THE ISSUING INSURER(S), AUTHORIZED REPRESENTATIVE OR PRODUCER, AND THE CERTIFICATE HOLDER.

IMPORTANT: If the certificate holder is an ADDITIONAL INSURED, the policy(ies) must have ADDITIONAL INSURED provisions or be endorsed. If SUBROGATION IS WAIVED, subject to the terms and conditions of the policy, certain policies may require an endorsement. A statement on this certificate does not confer rights to the certificate holder in lieu of such endorsement(s).

PRODUCER Insurance Office of America Abacoa Town Center 1200 University Blvd, Suite 200 Jupiter, FL 33458	CONTACT NAME: Dianne Klaus	
	PHONE (A/C, No, Ext): (561) 721-3746	FAX (A/C, No):
	E-MAIL ADDRESS: Dianne.Klaus@ioausa.com	
	INSURER(S) AFFORDING COVERAGE	NAIC #
	INSURER A: United Specialty Insurance Company	12537
	INSURER B: RLI Insurance Company	13056
	INSURER C: Bridgefield Employers Insurance Company	10701
	INSURER D: Upland Specialty Insurance Company	16988
	INSURER E: AGCS Marine Insurance Company	22837
	INSURER F:	
INSURED GRSC, Inc. 1843 NW Dove Ct. Stuart, FL 34994		

COVERAGES**CERTIFICATE NUMBER:****REVISION NUMBER:**

THIS IS TO CERTIFY THAT THE POLICIES OF INSURANCE LISTED BELOW HAVE BEEN ISSUED TO THE INSURED NAMED ABOVE FOR THE POLICY PERIOD INDICATED. NOTWITHSTANDING ANY REQUIREMENT, TERM OR CONDITION OF ANY CONTRACT OR OTHER DOCUMENT WITH RESPECT TO WHICH THIS CERTIFICATE MAY BE ISSUED OR MAY PERTAIN, THE INSURANCE AFFORDED BY THE POLICIES DESCRIBED HEREIN IS SUBJECT TO ALL THE TERMS, EXCLUSIONS AND CONDITIONS OF SUCH POLICIES. LIMITS SHOWN MAY HAVE BEEN REDUCED BY PAID CLAIMS.

INBR LTR	TYPE OF INSURANCE	ADDL INSD	SUBR WVD	POLICY NUMBER	POLICY EFF (MM/DD/YYYY)	POLICY EXP (MM/DD/YYYY)	LIMITS	
A	<input checked="" type="checkbox"/> COMMERCIAL GENERAL LIABILITY <input type="checkbox"/> CLAIMS-MADE <input checked="" type="checkbox"/> OCCUR	X	X	ATN25112102	12/23/2025	12/23/2026	EACH OCCURRENCE \$ 1,000,000	
							DAMAGE TO RENTED PREMISES (Ea occurrence) \$ 50,000	
							MED EXP (Any one person) \$ 10,000	
							PERSONAL & ADV INJURY \$ 1,000,000	
							GENERAL AGGREGATE \$ 2,000,000	
							PRODUCTS - COMP/OP AGG \$ 2,000,000	
							Total Agg/Proj \$ 5,000,000	
B	AUTOMOBILE LIABILITY <input type="checkbox"/> ANY AUTO OWNED AUTOS ONLY <input type="checkbox"/> SCHEDULED AUTOS <input checked="" type="checkbox"/> HIRED AUTOS ONLY <input checked="" type="checkbox"/> NON-OWNED AUTOS ONLY	X	X	CAP9511761	12/23/2025	12/23/2026	COMBINED SINGLE LIMIT (Ea accident) \$ 1,000,000	
							BODILY INJURY (Per person) \$	
							BODILY INJURY (Per accident) \$	
							PROPERTY DAMAGE (Per accident) \$	
							\$	
A	<input type="checkbox"/> UMBRELLA LIAB <input checked="" type="checkbox"/> OCCUR <input checked="" type="checkbox"/> EXCESS LIAB CLAIMS-MADE			BTN2513555	12/23/2025	12/23/2026	EACH OCCURRENCE \$ 3,000,000	
							AGGREGATE \$ 3,000,000	
							DED RETENTION \$	
C	WORKERS COMPENSATION AND EMPLOYERS' LIABILITY ANY PROPRIETOR/PARTNER/EXECUTIVE OFFICER/MEMBER EXCLUDED? (Mandatory in NH)	Y	N/A	X	196-65410	1/1/2026	1/1/2027	<input checked="" type="checkbox"/> PER STATUTE <input type="checkbox"/> OTHER
								E.L. EACH ACCIDENT \$ 1,000,000
								E.L. DISEASE - EA EMPLOYEE \$ 1,000,000
								E.L. DISEASE - POLICY LIMIT \$ 1,000,000
D	Excess Auto Liab			USXTL1181725	12/23/2025	12/23/2026	Each Occurrence 1,000,000	
E	Equipment Floater			MXI93095557	1/27/2026	1/27/2027	Leased/Rented Equpt 50,000	

DESCRIPTION OF OPERATIONS / LOCATIONS / VEHICLES (ACORD 101, Additional Remarks Schedule, may be attached if more space is required)
 ITB 26-01 Beachcomber Lane and Pebble Lane Roadway and Sewer Project
 Certificate Holder is included as additional Insured with respect to General Liability per form CG2010 (04/13) Ongoing Operations and per form CG2037 (04/13) Completed Operations as required by written contract with the Named Insured, fully executed prior to the Named Insured's work.

General Liability coverage is primary and non-contributory per form VEN05100 (02/20) as required by written contract with the Named Insured, fully executed prior to the Named Insured's work.

SEE ATTACHED ACORD 101

CERTIFICATE HOLDER**CANCELLATION**

Town of Indian River Shores 6001 Highway A1A Indian River Shores, FL 32963	SHOULD ANY OF THE ABOVE DESCRIBED POLICIES BE CANCELLED BEFORE THE EXPIRATION DATE THEREOF, NOTICE WILL BE DELIVERED IN ACCORDANCE WITH THE POLICY PROVISIONS. AUTHORIZED REPRESENTATIVE
--	---

ACORD 25 (2016/03)

© 1988-2015 ACORD CORPORATION. All rights reserved.

The ACORD name and logo are registered marks of ACORD



ADDITIONAL REMARKS SCHEDULE

AGENCY Insurance Office of America		NAMED INSURED GRSC, Inc. 1643 NW Dove Ct. Stuart, FL 34994	
POLICY NUMBER SEE PAGE 1			
CARRIER SEE PAGE 1	NAIC CODE SEE P 1	EFFECTIVE DATE: SEE PAGE 1	

ADDITIONAL REMARKS

THIS ADDITIONAL REMARKS FORM IS A SCHEDULE TO ACORD FORM,
 FORM NUMBER: ACORD 25 FORM TITLE: Certificate of Liability Insurance

Description of Operations/Locations/Vehicles:
 General Liability Waiver of Subrogation applies per form CG2404 (05/09) as required by written contract with the Named Insured, fully executed prior to the Named Insured's work.

Certificate Holder is included as additional insured with respect to Automobile Liability as required by a written contract per form #TRS700. Blanket Waiver of Subrogation applies when required by a written contract per form #TRS713.

Workers' Compensation Blanket Waiver of Subrogation applies per form WC000313.



THE TOWN OF INDIAN RIVER SHORES

AGENDA ITEM

TO: Town Council

FROM: James Harpring, Town Manager

DATE: April 14, 2026

SUBJECT: Budget Hearing and Council Meeting Schedule

BACKGROUND:

At the November 20, 2025 Regular Town Council meeting, Town Council adopted their 2026 meeting schedule that scheduled the final Public Budget Hearing for September 22, 2026 @ 5:01 p.m. This follows the regularly scheduled Town Council meeting beginning at 3:30 p.m.

Florida statute 200.065 (4) (d) provides the following:

“Within 15 days after the meeting adopting the tentative budget, the taxing authority shall advertise in a newspaper of general circulation in the county as provided in subsection (3), its intent to finally adopt a millage rate and budget. A public hearing to finalize the budget and adopt a millage rate shall be held not less than 2 days nor more than 5 days after the day that the advertisement is first published.”

To keep the originally scheduled Final Public Budget Hearing date of September 22, 2026, the earliest Council can meet for the first Public Budget Hearing is September 3, 2026. The Final Public Budget Hearing advertisement must appear no earlier than September 17, 2026 nor later than Friday, September 18, 2026. The Press Journal does not publish on Saturdays. A Sunday publication date would not allow for readvertisement if necessary.

RECOMMENDATION:

Establish Budget Hearing Dates and review the remainder of the Town Council calendar.

ATTACHMENTS:

Current Town Council Meeting Dates and Holidays as established on November 20, 2025.



6001 Highway A1A • Indian River Shores, FL 32963 • (772) 231-1771 • www.irshores.com

To provide a high level of personal service with integrity and professionalism to ensure an unparalleled quality of life.



TOWN COUNCIL MEETING SCHEDULE – 2026

JANUARY:	Thursday, January 22, 2026 at 9:00 a.m.
FEBRUARY:	Tuesday, February 17, 2026 at 9:00 a.m.
MARCH:	Thursday, March 26, 2026 at 9:00 a.m.
APRIL:	Thursday, April 23, 2026 at 9:00 a.m.
MAY:	Thursday, May 28, 2026 at 9:00 a.m.
JUNE:	Thursday, June 25, 2026 at 9:00 a.m.
JULY:	Thursday, July 23, 2026 at 9:00 a.m.
AUGUST:	Thursday, August 27, 2026 at 9:00 a.m.
SEPTEMBER:	Thursday, September TBD at 5:01 p.m. (First Public Budget Hearing) Tuesday, September 22, 2026 at 3:30 p.m. (Regular Town Council Meeting) Tuesday, September 22, 2026 at 5:01 p.m. (Final Public Budget Hearing)
OCTOBER:	Thursday, October 22, 2026 at 9:00 a.m.
NOVEMBER:	Thursday, November TBD at 9:00 a.m.
DECEMBER:	Thursday, December TBD at 9:00 a.m.

All meetings are held in Council Chambers, 6001 Highway A1A, Indian River Shores, FL.

HOLIDAY CLOSINGS – 2026

New Year's Day	January 1, 2026
President's Day	February 16, 2026
Good Friday	April 3, 2026
Memorial Day	May 25, 2026
Independence Day Holiday	July 3, 2026
Labor Day	September 7, 2026
Veteran's Day	November 11, 2026
Thanksgiving Day	November 26, 2026
Thanksgiving Holiday	November 27, 2026
Christmas Eve	December 24, 2026
Christmas Day	December 25, 2026



AGENDA ITEM

TO: Town Council
James Harpring, Town Manager

FROM: Janice C. Rutan, Town Clerk

DATE: April 10, 2026

SUBJECT: Resolution No. 26-01

BACKGROUND:

The Town of Indian River Shores will be holding a Municipal Election on November 3, 2026. Resolution No. 26-01 designates the time and place for filing, sets the times and dates for qualifying, sets the filing fees and appoints a municipal canvassing board.

RECOMMENDATION:

Approve Resolution No. 26-01 – Municipal Election

ATTACHMENTS:

Resolution No. 26-01



RESOLUTION NO. 26-01

A RESOLUTION ADOPTED BY THE TOWN OF INDIAN RIVER SHORES, FLORIDA, DESIGNATING THE DATE, TIME AND PLACE FOR FILING FOR THE OFFICES FOR THE POSITION OF TOWN COUNCIL PRIOR TO THE MUNICIPAL ELECTION TO BE HELD TUESDAY, NOVEMBER 3, 2026 SETTING THE DATES AND TIMES TO QUALIFY FOR PUBLIC OFFICE; SETTING THE FILING FEES; APPOINTING AN ELECTION CANVASSING BOARD AND PROVIDING FOR AN EFFECTIVE DATE.

WHEREAS, the Town of Indian River Shores will conduct a Municipal Election on Tuesday, November 3, 2026, between the hours of 7:00 a.m. and 7:00 p.m. within all the Town of Indian River Shores precincts;

NOW, THEREFORE, BE IT RESOLVED BY THE TOWN COUNCIL OF THE TOWN OF INDIAN RIVER SHORES, FLORIDA, THAT:

Section 1. Any qualified elector of the Town of Indian River Shores, Florida who has resided within the Town for one year immediately preceding the election in which they are candidates, and who is qualified to hold an elective office under the Charter and Code of Ordinances of the Town of Indian River Shores, Florida and who shall desire to become a candidate for the Office of Town Council shall file with the Town Clerk/Filing Officer, a written request that his/her name be placed upon the ballot for election and declare themselves a bona fide candidate for such office.

Section 2. Such written notice must be filed with the Town Clerk/Filing Officer between noon, on the first day after the regular Town Council meeting in April until noon on the first day after the regular Town Council meeting in July in the same year as the election is held.

Section 3. At the time of filing, any candidate for the Office of Town Council shall submit a filing fee of \$25.00 to the Town Clerk with the filing of the petition. Each filing fee must be paid from a Qualifying Depository Fund and signed by a duly appointed Campaign Treasurer in accordance with F.S.106.021.

Section 4. Any candidate may withdraw his/her name at any time before the election ballot information is delivered to the Indian River County Supervisor of Elections for printing.

Section 5. All of the Town of Indian River Shores precincts; precinct numbers 31 and 32, are hereby authorized for the Municipal Election to be held on Tuesday, November 3, 2026 for the Office of Town Council of the Town of Indian River Shores, Florida.

Section 7. The Town of Indian River Shores shall designate the Town Manager, Town Attorney and Town Clerk to serve as the members of the Town's Canvassing Board for said election.

Section 8. Upon closing the polls at 7:00 p.m. on Tuesday, November 3, 2026, the Indian River County Supervisor of Elections, will count the ballots for all Town of Indian River Shores precincts numbered 31 and 32. Once the Indian River County Supervisor of Elections has officially certified the ballots cast for all Town of Indian River Shores precincts for the November 3, 2026 Municipal Election, the candidates receiving the plurality of the votes casts for that particular office shall be elected.

Section 9. Should any section or provision of this Resolution or portion thereof, any paragraph, sentence or word be declared by a court of competent jurisdiction to be invalid, such decision shall not affect the remainder of this Resolution.

Section 10. This Resolution shall become effective upon its adoption.

Passed and adopted by the Town Council of the Town of Indian River Shores on April 23, 2026.

Brian T. Foley, Mayor

Attest:

Janice C. Rutan, Town Clerk

MARCH (2026)

PERMITS***	PERMITS ISSUED THIS MONTH		PERMITS ISSUED FS/YR TO DATE		CONSTRUCTION VALUATION FS/YR TO DATE		FEES COLLECTED THIS MONTH		FEES COLLECTED FISCAL YTD	
	2024/25	2025/26	2024/25	2025/26	2024/25	2025/26	2024/25	2025/26	2024/25	2025/26
NEW CONSTRUCTION										
SINGLE FAMILY	1	4	7	8	\$ 16,731,750.00	\$ 14,109,525.00				
MULTI FAMILY	0	0	0	0	\$ -	\$ -				
COMMERCIAL	0	1	0	1	\$ -	\$ 11,901,298.00				
(SUB-TOTAL)	1	5	7	9	\$ 16,731,750.00	\$ 26,010,823.00				
ADDITIONS / ALTERATIONS										
SINGLE FAMILY	33	38	189	174	\$ 20,185,202.34	\$ 13,460,388.56				
MULTI FAMILY	8	6	49	41	\$ 3,538,824.15	\$ 906,742.25				
COMMERCIAL	1	7	19	34	\$ 5,289,315.42	\$ 16,484,515.63				
(SUB-TOTAL)	42	51	257	249	\$ 29,013,341.91	\$ 30,851,646.44				
OTHER PERMITS (MISC.)										
(TOTALS)	54	80	337	397	\$ 3,825,465.75	\$ 6,251,096.25				
INSPECTIONS*							\$ 63,540.32	\$ 126,104.42	\$ 404,228.24	\$ 572,102.95
(TOTALS)	313	290	2042	1795						

PLAN REVIEWS*	2024/25	2025/26	2024/25	2025/26		
(TOTALS)	133	158	716	677		

Inspections are completed within 24 hrs of request.

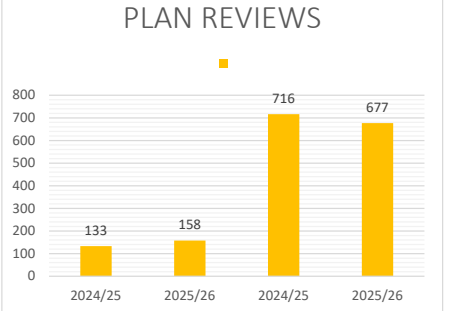
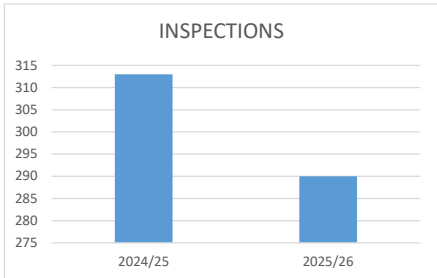
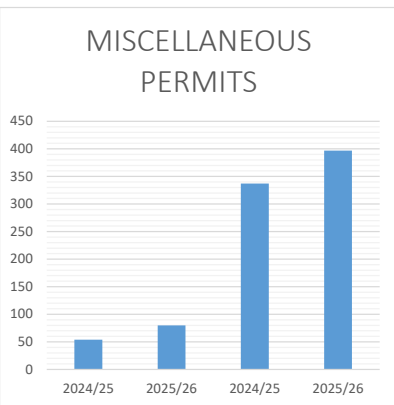
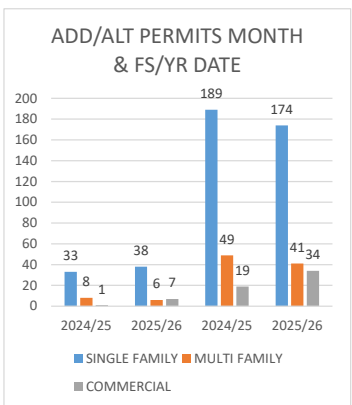
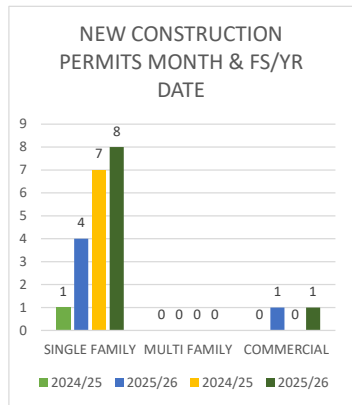
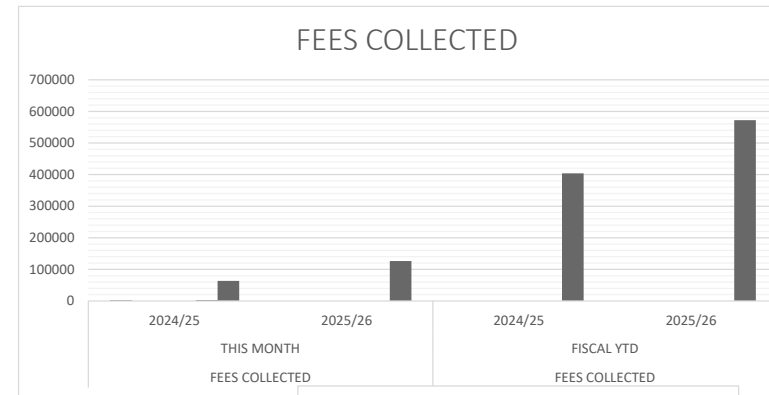

TOWN MANAGER
JAMES HARPRING
TOWN CLERK
JANICE RUTAN
TOWN ATTORNEY
PETER J. SWEENEY, JR.

MAYOR
BRIAN T. FOLEY

VICE MAYOR
BOB AUWAERTER

COUNCIL:
JAMES M. ALTIERI
JESSE L. "SAM" CARROLL, JR.
PETER TEDESKO



6001 Highway A1A, Indian River Shores, FL 32963
(772) 231-1771

To: Town Manager Jim Harpring

From: Fire Marshal/Code Enforcement Official/Building Inspector, Jacob Maikranz

Date: March 11, 2026 – April 16, 2026

Ref: Monthly Code Enforcement Report

The following Code Enforcement violations were observed and rectified:

ANNUAL FIRE & LIFE SAFETY INSPECTIONS

An annual fire and life safety inspection was completed at River Club Condominiums, CVS, Park Shores Condo, Harbour Island Club, Sea Colony Condo and Clubhouse, Sable Oaks in Bermuda Bay, and Vera Cruz. Fire Code violations were observed; inspection reports were emailed to the respective property management companies and were given 30 days to rectify the violations and become compliant with the Fire Code, except for River Club Condominiums 501, 601, 701, and 801. Four (4) fire and life safety hazards were observed during the annual inspection on 4/16/2026 and required immediate attention to rectify the violation by 4/27/2026.

- KNOX BOX INSPECTIONS:

- 1) The Knox Boxes and Gate Access Switches (if available) located at River Club Condominiums, CVS, Park Shores Condo, Harbour Island Club, Sea Colony Condo and Clubhouse, Sable Oaks in Bermuda Bay, and Vera Cruz were inspected during the annual fire inspection with no discrepancies. Access keys within the Knox Boxes are up to date.

- OTHER:

- 1) Written notices were sent to the Baytree and Indian Trails HOA Board Members and Property Management companies regarding low-lying trees that are hindering fire department access within the communities. The obstructions are a violation of the Florida Fire Prevention Code (FFPC) and Town Ordinance.

SIGN VIOLATIONS

- Seven (7) Real Estate and zero (0) advertisement signs were removed from Highway A1A's right-of-way. The real estate agents were notified, and a written warning with a copy of the Town's Ordinance was issued, except for one (1) real estate agent who is a repeat offender. One (1) citation was issued, \$50 per violation, along with a copy of the Towns Sign Ordinance.

1) Citation CE-2026-07 - \$150 (Total of 3 signs)

ORDINANCE COMPLAINTS

- Code complaint received regarding metal sheathing acting as a barrier between two residential lots. A civil violation notice was sent to the property owner via certified mail to immediately remove the barrier as it is a potential life safety hazard.

1) **UPDATE** 3/20/2026 – The homeowners of the property in violation were notified by their HOA to remove the sheathing. The violation was rectified and the Code Case was closed.

SHORT-TERM VACATION RENTALS

- No other properties within the Town were found to be in violation of the Towns STVR Ordinance per the Rentalscape report on 4/16/2026.

LIEN REQUESTS

- Between March 11, 2026, through April 16, 2026, thirty-three (33) lien requests were processed.

SEA TURTLE SEASON

A pre-season lighting survey was completed February 25, 2026, by a third-party vendor, Ecological Associates Inc. (EAI). The pre-season survey was conducted to gather a baseline for potential properties that may be in violation of the Town Ordinance and State Law. Educational brochures and letters will be sent to all ocean side properties within the Town providing helpful tips, ordinance requirements, and contact information for local agencies.

The first official lighting survey is scheduled for the week of April 27th-30th.

OTHER

- Reviewed fire plans, building permits and plans for code compliance for renovated, altered, existing and new buildings. After review, on-site inspections were requested and scheduled by the contractors. All inspections were conducted, and re-inspections were scheduled, if needed, when deficiencies were observed. All properties met compliance after re-inspection.
- Conducted random bi-weekly checks through the Town owned streets and Pebble Bay Estates. During those checks, ten (10) properties were found to be in violation of Town Ordinance Section 162.021 – Parking. This information was logged for reference purposes only.

- A Stop Work Order was issued to a contractor for beginning work prior to permit issuance. Violation of the Florida Building Code 150.12.
- Received a question from a resident regarding the size, location, and installation requirements of street signs within a private community. The resident was provided a copy of the Manual on Uniform Traffic Control Devices for Streets and Highways which listed the general requirements.
- Met with multiple contractors, located at the Johns Island Parking Garage, to discuss the upcoming construction process.
- Received a question from a resident regarding the removal/trimming of an Oak Tree. The resident was directed to the Town's Tree Protection Officer for more assistance.
- Received a question from a contractor regarding the setback requirements for a pool, wall and fence. A copy of the Ordinance was given to the contractor.
- Noise Ordinance related question was received from a resident regarding construction noise. The resident was educated and was provided a copy of the Ordinance and the requirements within.

APRIL (2026)

VIOLATIONS AND LIEN REQUESTS	CODE ACTIVITY THIS MONTH		CODE ACTIVITY YEAR TO DATE	
	2025	2026	2025	2026
CODE ENFORCEMENT	4	5	32	96
FIRE CODE	16	19	56	51
BUILDING CODE		3	2	7
OTHER/LIEN REQUESTS	16	41	78	116
(SUB-TOTAL)	36	68	168	270

BREAKDOWN	ACTIVITY BY MONTH		ACTIVITY BY YEAR	
COMPLAINTS	2025	2026	2025	2026
ORDINANCE	4	4	11	47
BUILDING		3	2	7
SIGNS	2025	2026	2025	2026
ADVERTISEMENT			5	7
REAL ESTATE		7	16	47
STVR	2025	2026	2025	2026
ACTIVE/INSPECTED				1
INACTIVE/UNREGISTERED				
CANCELED				
LIEN REQUESTS	2025	2026	2025	2026
REQUESTS	14	33	69	94
FIRE INSPECTIONS	2025	2026	2025	2026
FIRE INSPECTIONS	16	18	56	48
OTHER	2025	2026	2025	2026
	2	3	9	19
TOTAL	36	68	168	270

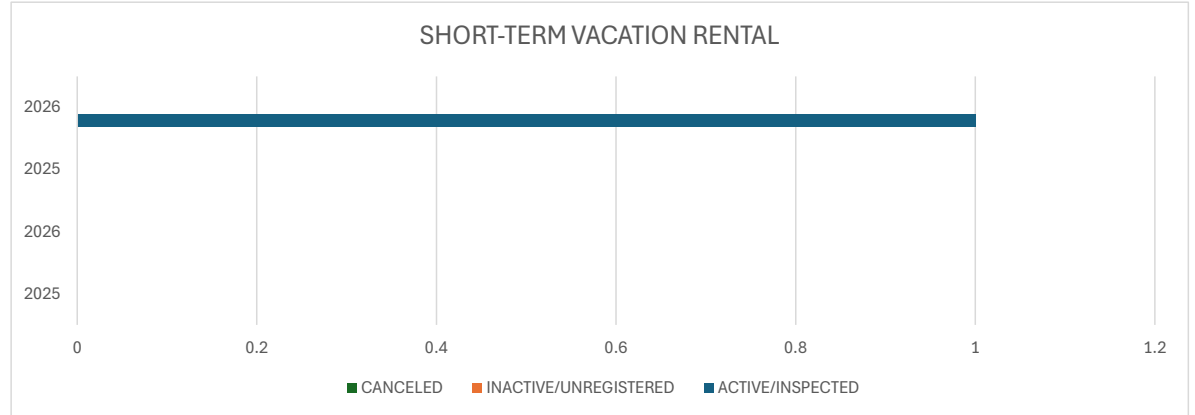
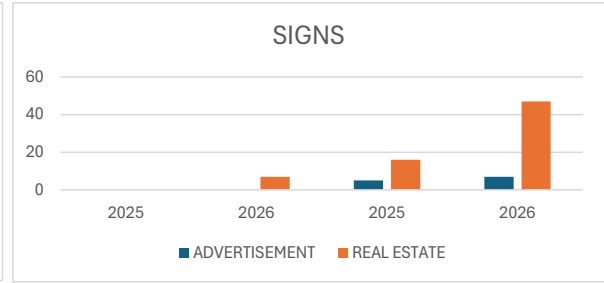
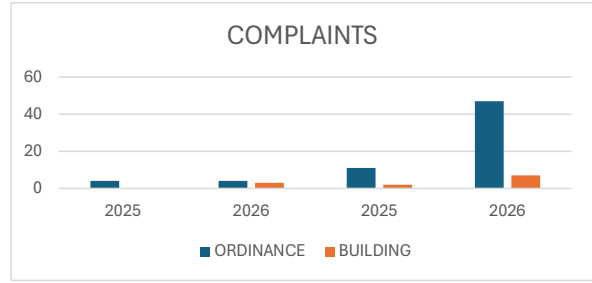
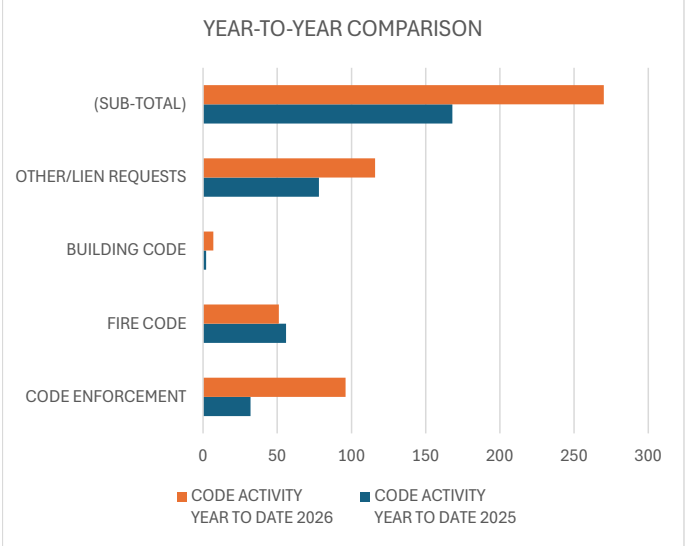
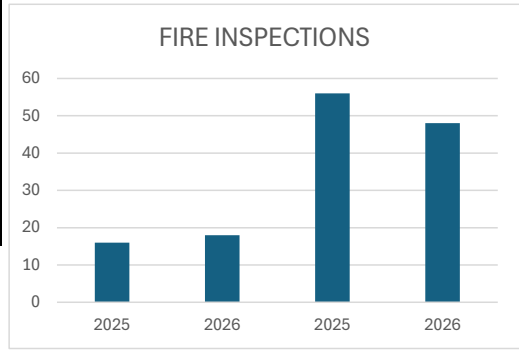
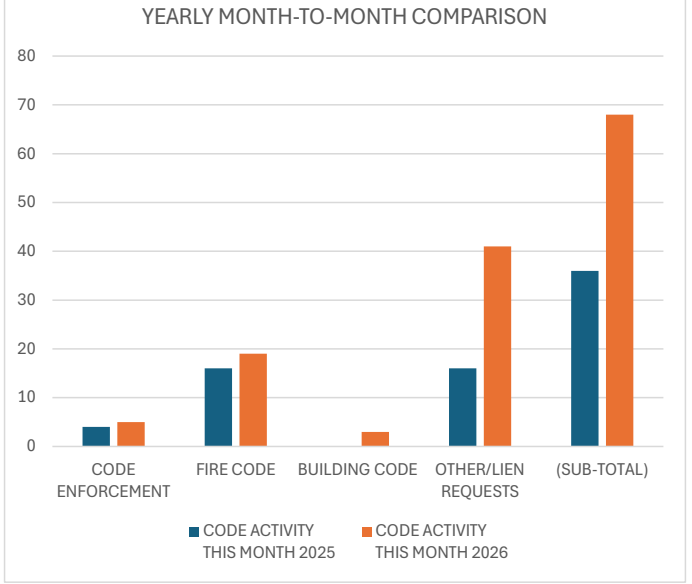
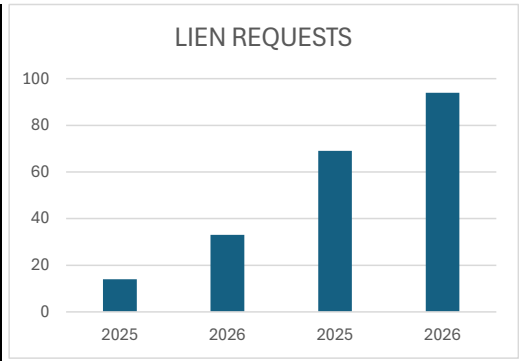



TO: Town Council
James Harpring, Town Manager

FROM: Lucy Scheidt, Facilities Director

DATE: April 15, 2026

SUBJECT: Facilities Department Report

NPDES MS4, BMAP and CRS

- Completed inspection post-rain events and prepared stormwater pollution prevention plan reports for compliance with NPDES MS4 permit requirements:
 - March 20th
 - April 6th
 - April 7th
 - April 8th
 - April 9th
 - Documentation of standing water at swales on Old Winter Beach Road identified post-multi day rain cycle.
- FDEM – Submission of Abatement Plan for FROC – Disaster Preparedness Plan.
- Securing quotes from vendors for heavy equipment rental in preparation for hurricane season.
- Coordination of internal meeting in May with all Departments for hurricane season preparation.

CEMETERY

- Lighting issue – coordinated with John’s Island to repair down pole.

BEACH, SR A1A AND ROADS

- Communication and coordination with FDOT - maintenance of right of way due to grass overgrowth grass between John’s Island to Old Winter Beach Road; review site and trim within R/W to improve the site distance at Indian Lane and A1A.
- Beachcomber Lane beach access maintenance post rain events
 - Removal of sand on stairs to allow for access.
 - Notification and coordination with Rotary Club for replacement of Drown Zero stand.
 - Post-n-rope impacted by storms: gathered and removal of fallen posts; secured rope around dune plantings; communication with contractor for proposal for reinstallation of posts; discussion with IRC Coastal Manager to determine recommended course of action.

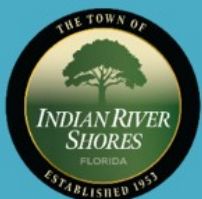

TOWN HALL, PSD AND TOWN LOT

- Town Hall landscaping - development of scope of service and coordination with landscapers for onsite visits for proposals for removal and replacement of dead shrubs, Clusia, and fire bush to replace with sod.
- Continued coordination with nursery for Public Safety Department hedge replacement; change in plantings from azaleas to oleanders.
- Completed install of wireless monitoring unit for generator at PSD to ensure routine test cycle and offsite observation by electrician and staff.
- Coordinated with FCG for removal and installation of new plantings (Clusia) at regulator station to replace sea grape impacted by the freeze.



Beachcomber Lane beach access



Old Winter Beach Road swales post-heavy rain events over multiple days.





THE TOWN OF INDIAN RIVER SHORES

Memorandum

TO: Town Council
James Harpring, Town Manager

FROM: Heather Christmas, Finance Director

DATE: April 11, 2026

SUBJECT: March 2026 Budget Analysis

The March 2026 budget analysis was prepared using financial data available as of April 11, 2026. To date, two amendments have been adopted to the FY 2025–2026 budget. It is recommended that budget amendments be reviewed in conjunction with this report. The next budget amendment is anticipated for May 2026.

The significant differences from the amended budget or other items of note are as follows:

1. Operating Revenues – The adopted budget did not include the solid waste collection franchise fee (approximately \$40,000 annually). The Town also sold or traded in several vehicles that were not budgeted, including a \$150,000 fire engine trade-in. In addition, the Town expects to receive approximately \$164,500 in grant funding for the Comprehensive Vulnerability Assessment update. A budget amendment is needed to recognize these revenues.
2. Town Manager – Prior to the establishment of the Facilities Department, the Facilities Coordinator’s salary was budgeted within the Town Manager’s department. With the creation of the Facilities Department, the director assumes department head responsibilities and receives a commensurate pay adjustment. Salary and related costs will be transferred to the Facilities Department effective April 2026.
3. Finance Department – The adopted budget included the HR Manager’s salary and benefits. Since adoption, the HR Manager retired and the position was eliminated; a Bookkeeper position was created to support Finance operations. A budget adjustment is needed to reflect the current staffing model and associated salary and benefit allocations.

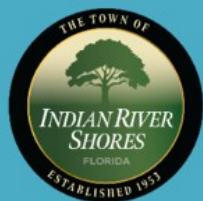

6001 Highway A1A • Indian River Shores, FL 32963 • (772) 231-1771 • www.irshores.com

To provide a high level of personal service with integrity and professionalism to ensure an unparalleled quality of life.

4. Facilities Department (formerly Public Works) – Public Works has been reorganized into a Facilities Department. The Facilities Coordinator position is reclassified to Facilities Director with leadership of the department. A budget adjustment is needed to reflect the vacancy and the revised departmental structure.
5. Legal - Attorney costs related to ongoing labor and utility matters are speculative. Adjustments, if needed, will be reflected in the unreserved fund balance. For this reason, no adjustment to budgetary expenditures is recommended at this time.
6. Town Engineer - In February, the Town Council approved an unbudgeted contract with Coastal Waterways to update the Town's Comprehensive Vulnerability Assessment. A budget amendment is needed to recognize approximately \$164,500 in related engineering expenditures (offsetting revenue noted in Item 1).
7. Capital Revenues – The insurance settlement for the ambulance was resolved. A budget amendment is needed to align the budget with final results.
8. Capital Expenditures – Building renovation costs did not require all contingency funds appropriated. In addition, the prior HVAC budget amendment included an estimate for a Town roof replacement; the roof was repaired under warranty. A budget amendment is needed to reflect actual costs and release unneeded appropriations.
9. Building Department Revenue - Building activity fluctuates based on permit volume and valuation. The Building Fund remains compliant with applicable Florida Statutes. Based on current projections, fee reductions for the upcoming fiscal year may be warranted due to higher-than-anticipated activity. Florida Statutes currently allow accumulated funds to be used for construction or expansion of Building Department facilities, which is under active consideration. If a fee adjustment is proposed for FY 2026–2027, staff will present it to the Council.
10. Building Department Capital – In February, the Town Council approved the purchase of a new vehicle for the department. A budget amendment is needed to recognize this expenditure.

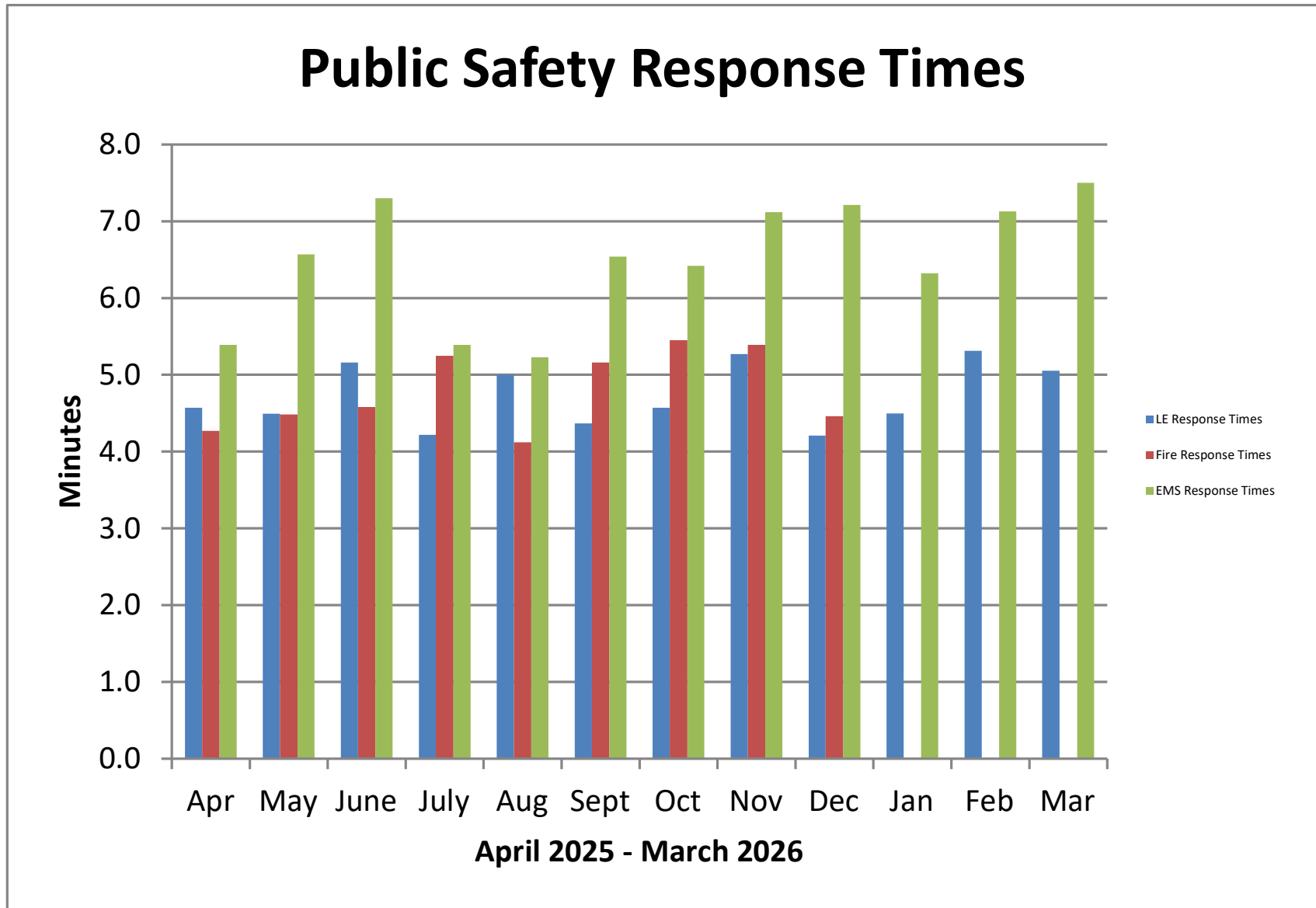

Public Safety Calls for Service

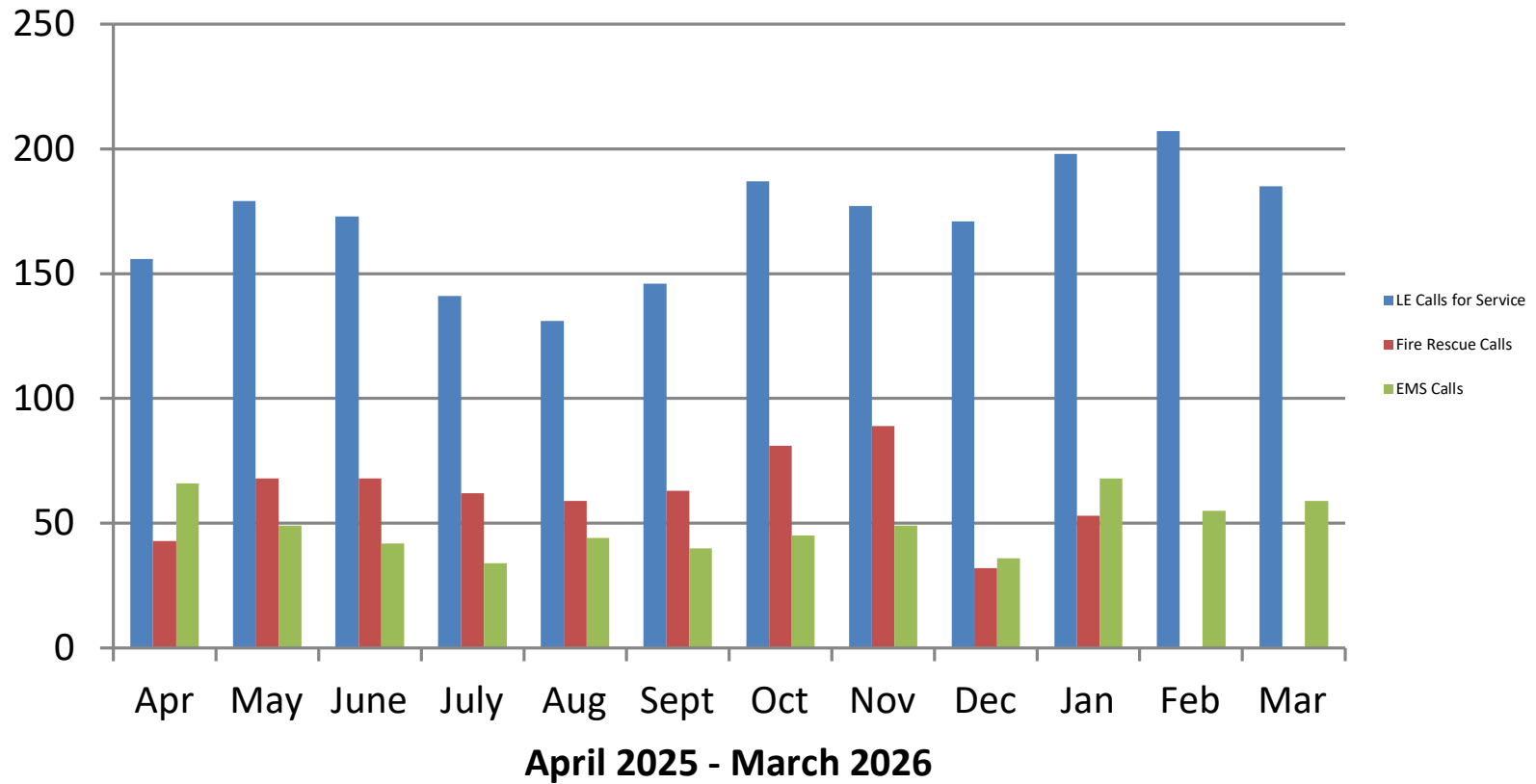

Law Enforcement Interactions with Public

